

THE  
**BARRETO**  
MODEL 712MT  
HYDRAULIC MICRO TRENCHER  
EXPLODED VIEWS WITH PART NUMBERS

CONGRATULATIONS!

You are now the proud owner of a BARRETO trencher. The following pages have detailed views of your trencher, along with corresponding part numbers. If you have any questions or need any replacement parts in the future, please contact us at your convenience. Our toll-free phone number, fax and email are listed below and parts may be ordered through any of these methods.

Thank you for your patronage and confidence in BARRETO equipment.

Barreto Manufacturing, Inc.  
Innovative Equipment Engineered to Last  
66498 Highway 203  
La Grande, OR 97850  
1-800-525-7348  
1-541-963-6755 Fax  
E-Mail: [info@barretomfg.com](mailto:info@barretomfg.com)  
Web Site: <http://www.barretomfg.com>

Machine Identification Record

BARRETO Customer number \_\_\_\_\_

Machine model number \_\_\_\_\_

Machine serial number \_\_\_\_\_

Engine manufacturer \_\_\_\_\_

Engine model number \_\_\_\_\_

Engine serial number \_\_\_\_\_

REF QTY.	PART NO.	DESCRIPTION
1	02269-HUB	WHEEL HUB ASSY, 1-1/8" BORE
2	1	03190-FW TIRE & RIM, 16" X 4", LEFT HAND
3	1	03191-FW TIRE & RIM, 16" X 4", RIGHT HAND
4	6	05042 NUT, LUG, 1/2-20 NF
5	2	02068 PIN, FREE WHEELING
6	2	05102 WASHER, 1/2 SAE ZINC HARDENED
7	4	05548 ROLL PIN (SLOTTED SPRING), 1/8 X 3/4 ZINC
8	2	03352 SPRING, CENTURY 3385
9	4	02083 SPACER, WHEEL
10	2	01077 MOUNTING PLATE, PIN, FREE WHEELING
11	2	03550 SPLIT RING-27

1 FOR TRENCHER, 03190-FW IS ON RIGHT SIDE, FOR TRENCHING IN REVERSE

2 FOR TRENCHER, 03191-FW IS ON LEFT SIDE, FOR TRENCHING IN REVERSE

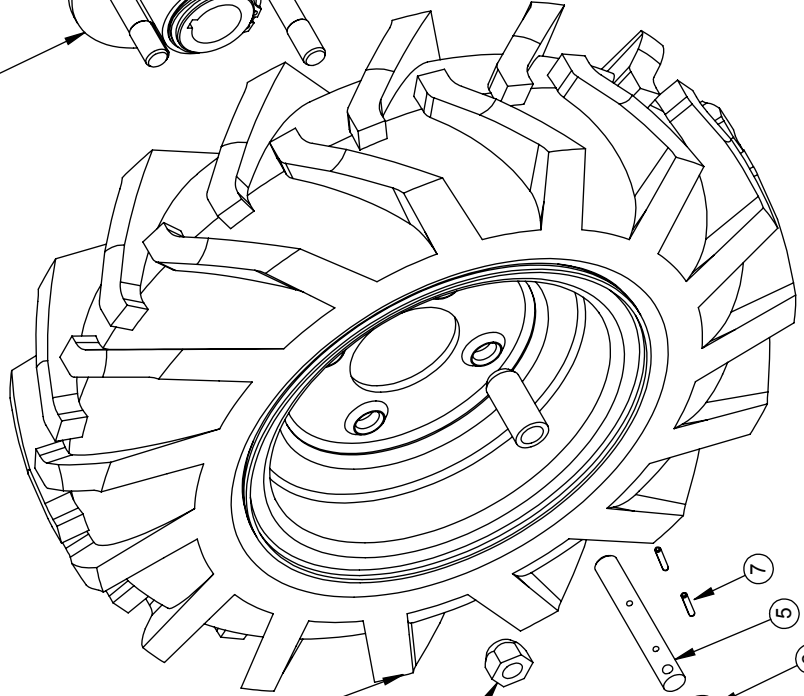
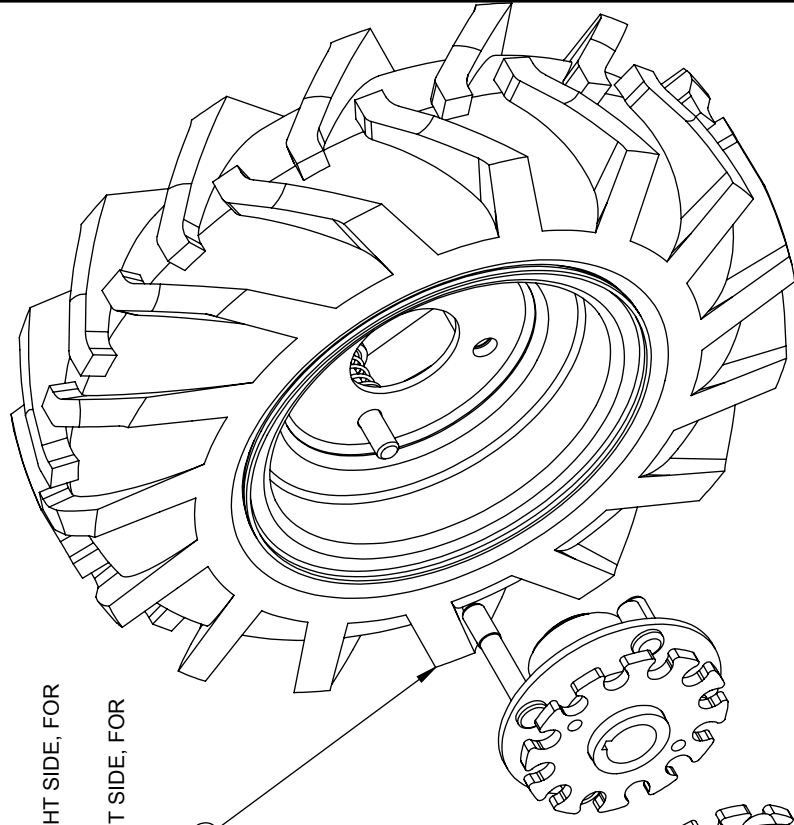

NOTES:

1. RIM ALONE IS PART NO. 03712.  
TIRE ALONE IS PART NO. 03193.
2. USAGE: 1 OF 00256 R1 PER 912, 916 & 918.

# BARRETO

TITLE: FREE WHEELING HUBS AND WHEELS  
 PRODUCT LINE: COMMON  
 SCALE: 1:4  
 SHEET 1 OF 1  
 DATE: 7/16/07  
 DWG# 00256 R1

UPDATED 10/10/16

$\Delta$  01039 SHIELD WAS 01026

**Can be ordered complete as p/n 00265.**

REF QTY.	PART NO.	DESCRIPTION
1	10311	CHAIN ROLLER
2	10320	ROLLER AXLE
3	10312	ROLLER SPACER
4	10887	O-RING, 2-020N70, 1 OD X 1/16 SECTION
5	01039	SHIELD, ROLLER BEARING
6	03043-S1	BEARING, 6205 RST, SINGLE SHIELD (GREASEABLE)
7	05024	SNAP RING, HO-200, 2" INTERNAL
8	05044	GREASE ZERK, 1/4-28 UNF
9	05046	NUT, GRIPCO, 1/2-13 NC G5 ZINC

**INSTALL BEARINGS WITH SEAL FACING OUTWARD**

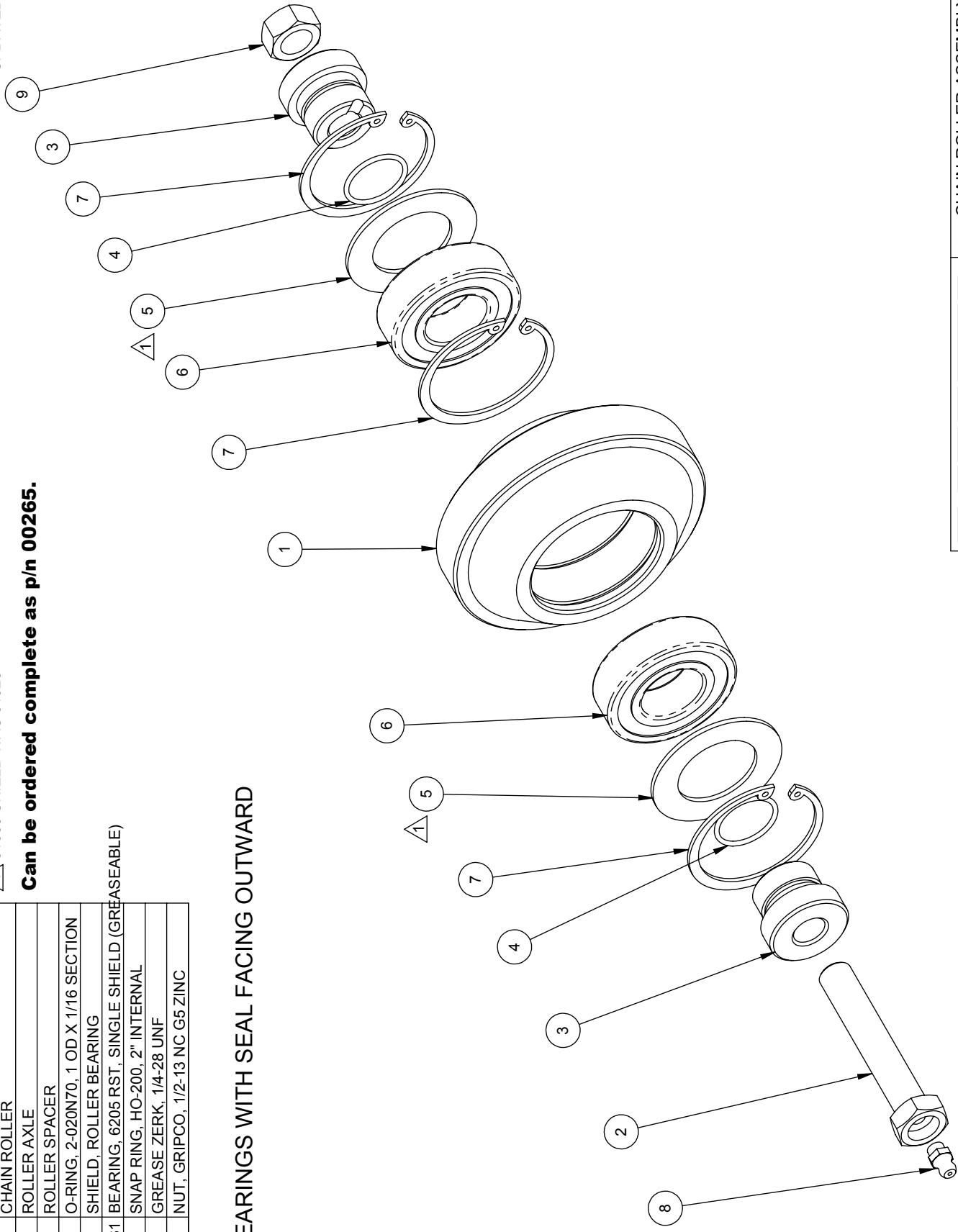

TITLE: CHAIN ROLLER ASSEMBLY

PRODUCT LINE: TRENCHEUR 912 DATE: 3/11/04

SCALE: 1:2 DWG#: 00265

SHEET 1 OF 1

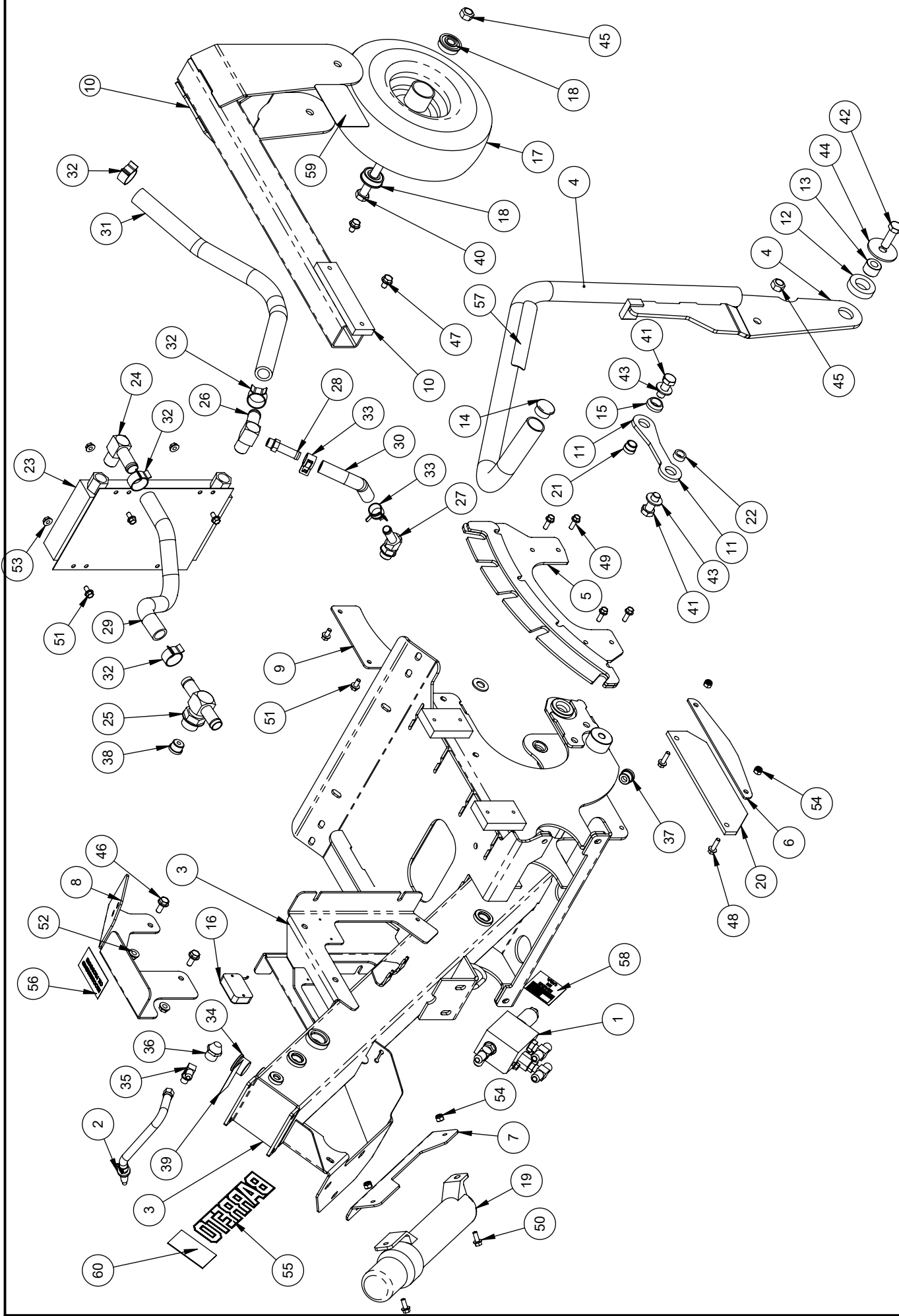

TITLE: BODY ASSEMBLY

PRODUCT LINE: 712

DATE: 9/10

SCALE: 1:8

DWG# 00472

SHEET 1 OF 2

# BARRETO

ITEM NO.	PART NUMBER	DESCRIPTION	QTY.	ITEM NO.	PART NUMBER	DESCRIPTION	QTY.
1	00481	UNLOADER ASSEMBLY	1	40	05154	HH CAP SCREW, 1/2-13 NC X 5 G5 ZINC	1
2	11987	BREATHER HOSE ASSY	1	41	05323	HH CAP SCREW, 1/2-13 NC X 1-1/4 G5 ZINC	2
3	11894 R1	BODY	1	42	05300-01	HH CAP SCREW, 1/2-13 NC X 1-1/2 G5 ZINC	1
4	11914	RAISE LEVER	1	43	05102	WASHER, 1/2 SAE ZINC HARDENED	3
5	11915	LIFT STOPS	1	44	12981	FENDER WASHER, 1/2 X 2 X 1/8 ZN	1
6	11474	FLAP BACKING	1	45	05046	NUT, GRIPCO, 1/2-13 NC G5 ZINC	2
7	12143	CANISTER MOUNT	1	46	05140	WHIZ-LOCK 5/16 - 18 X 3/4	2
8	12854	HOSE GUARD	1	47	05169	WHIZ-LOCK 5/16 - 18 X 1/2	2
9	12097	SHIELD GUIDE	1	48	05535	WHIZ-LOCK 1/4 - 20 X 7/8	2
10	11909	WHEEL MOUNT	1	49	05049	WHIZ-LOCK 1/4 - 20 X 3/4	4
11	11965	LIFT LINK	1	50	05069	WHIZ-LOCK 1/4 - 20 X 5/8	2
12	11905	LEVER SPRING	1	51	05051	WHIZ-LOCK 1/4 - 20 X 1/2	6
13	11910 R1	LIFT SPACER	1	52	05364	NUT, 5/16-18 NC, SERRATED FLANGE, ZN	2
14	12130	TUBE END CAP - 1-1/4"	1	53	05419	NUT, 1/4-20 NC, SERRATED FLANGE, ZN	4
15	10958	RUBBER BUSHING	1	54	05096	NUT, NYLOCK, 1/4-20 NC ZINC	4
16	03009-R1	HOUR METER, WITH FLASH ALERT	1	55	03040-11	DECAL, "BARRETO", 2-3/16 X 7-3/8	1
17	10347	TIRE & RIM 4.10/3.50-4	1	56	03346	DECAL "RECOMMENDED OIL PRODUCTS"	1
18	10347.50	BEARING, 1/2 BORE	2	57	04445-03	DECAL, TRENCH DEPTH	1
19	12090	INSTRUCTION CANISTER	1	58	03040-01	DECAL, "MADE IN USA"	1
20	11475	FLAP	1	59	04445-02	DECAL, 712	1
21	11974 R1	LIFT BUSHING	1	60	04445-08	DECAL, 712 SERIAL NUMBER	1
22	11975 R1	LIFT BUSHING	1				
23	10527	OIL COOLER, B & M 70273, 11 X 5.75	1				
24	04227	FITTING, 4501-12-8	1				
25	11771-M	FITTING, 4606-12-12-12, MACHINED	1				
26	04227B-P	FITTING, 4501-12-8, TAPPED #6	1				
27	04216	FITTING, 4603-8-8	1				
28	11667	FITTING, 4604-8-6	1				
29	11972	HOSE, TANK OUT / COOLER IN, 3/4"	1				
30	11971	HOSE, COOLER OUT / TANK	1				
31	11970	HOSE, PUMP SUCTION, 3/4 WIRE HELIX	1				
32	05008	HOSE CLAMP CTB 27	4				
33	12131	CLAMP, 1/2" HOSE, CTB-20	2				
34	10526	FITTING, 6409-12 PLUG	1				
35	04555	FITTING, 6801-4-4	1				
36	03503	SIGHT GAUGE	1				
37	10361	FITTING, 6409-8 PLUG	1				
38	12094	ORFICE PLUG, .25	1				
39	03040-06	DECAL, "HYDRAULIC OIL ONLY"	1				

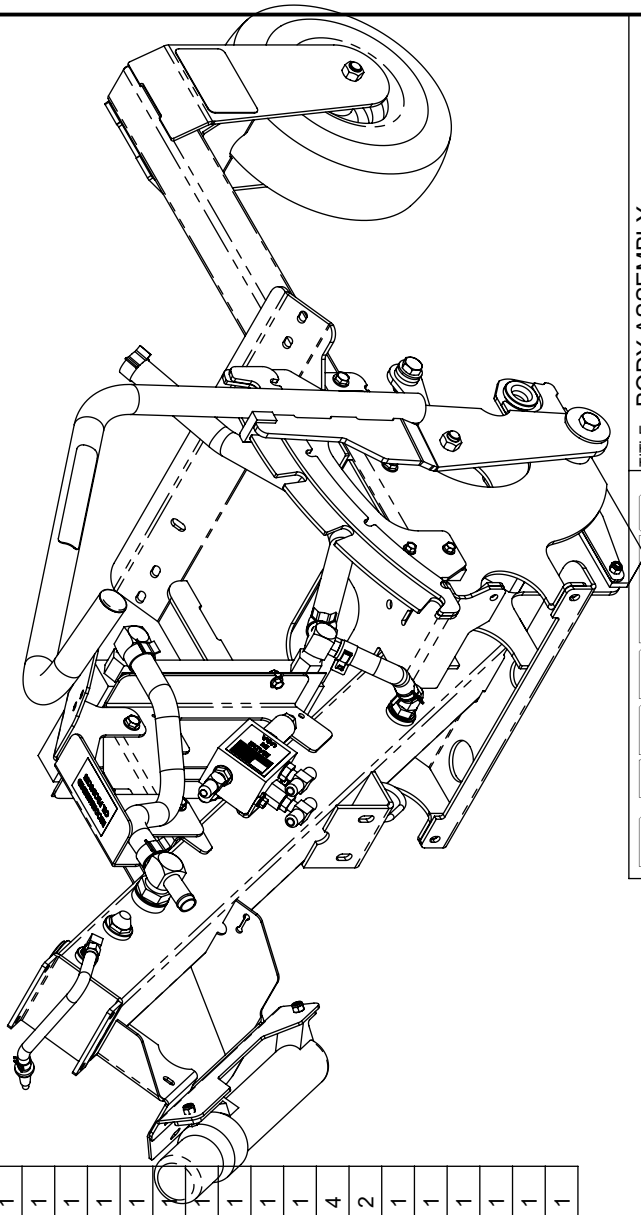

# BARRETO

TITLE: BODY ASSEMBLY

PRODUCT LINE: 712

DATE: 9/10

SCALE: 1:8

DWG# 00472

SHEET 2 OF 2

REF.	QTY.	PART NO.	DESCRIPTION	REF.	QTY.	PART NO.	DESCRIPTION
1	1	100480-PS	VALVE ASSEMBLY	49	1	05266	NUT, GRIPCO, 1/4-28 NF G5 ZINC
2	1	11976WD	HANDLE BARS	50	1	10773	NUT, GRIPCO, 1/4-20 NC G5 ZINC
3	1	12048	FILTER MOUNT	51	3	05267	NUT, 1/4-28 NF ZINC
4	1	11980	TRENCH LEVER	52	3	05096	NUT, NYLOCK, 1/4-20 NC ZINC
5	1	12017	WHEEL DRIVE LEVER	53	2	05419	NUT, 1/4-20 NC, SERRATED FLANGE, ZN
6	1	12088	ADJUSTER				
7	1	12032	PULL LINK				
8	1	11982	VALVE ROCKER				
9	2	11741	SPACER				
10	1	12019	VALVE SPACER				
11	1	106421	GROUND WIRE, IGNITION SWITCH				
12	1	106420	ROCKER SWITCH, IGNITION OFF/ON				
13	1	103806	QUICK-SPLICE				
14	2	03036	GRIP, 3/8 X 3-1/2				
15	1	104445-01	TRENCH DECAL				
16	1	104445-04	DRIVE DECAL				
17	1	103341-07	DECAL, "IGNITION OFF/ON"				
18	1	103341-24	DECAL, "WARNING - NO PARKING BRAKE"				
19	1	104445-06	DECAL, "REVERSE TO TRENCH"				
20	4	11979	BUSHING, IGUS MFI-0608-03				
21	1	104513-M	VALVE RD-2508-M4, 2200 psi				
22	1	103509	BRACKET & PINS, COMES WITH VALVE				
23	1	12026	HOSE, DRIVE VALVE / CHAIN VALVE, 3/8"				
24	1	12025	HOSE, DUMP / FILTER EL. 1/2"				
25	2	12131	CLAMP, 1/2" HOSE, CTB-20				
26	1	11973	HOSE, FILTER / TANK 3/4"				
27	2	05008	HOSE CLAMP CTB 27				
28	2	10404	FITTING, 6801-6-8				
29	1	104202-M	FITTING, 4601-12-12, TOP PORTED #8				
30	1	10405	FITTING, 6801-6-10				
31	1	104572	FITTING, 4601-8-8				
32	1	104403	FILTER HEAD, #12 O-RING				
33	1	11006	FITTING, 6407-12-10				
34	1	103951	FILTER, HYDRAULIC OIL, WITH BY-PASS				
35	1	103511	BALL JOINT, 1/4-28 UNF				
36	2	05054	HH CAP SCREW, 5/16-18 NC X 1-3/4 G5 ZINC				
37	1	05294	HH CAP SCREW, 5/16-18 NC X 1-1/2 G5 ZINC				
38	4	05140	WHIZ-LOCK 5/16 - 18 X 3/4				
39	4	05273	NUT, NYLOCK, 5/16-18 NC ZINC				
40	3	05364	NUT, 5/16-18 NC, SERRATED FLANGE, ZN				
41	1	05503	SH SET SCREW, 1/4-28 X 2 PLN				
42	1	05366	WHIZ-LOCK 1/4 - 20 X 1-1/4				
43	1	05368	WHIZ-LOCK 1/4 - 20 X 1				
44	2	05535	WHIZ-LOCK 1/4 - 20 X 7/8				
45	1	05049	WHIZ-LOCK 1/4 - 20 X 3/4				
46	4	05069	WHIZ-LOCK 1/4 - 20 X 5/8				
47	1	05502	SH SHOULDER SCREW, (5/16) X 1/4 NC				
48	3	05081	WASHER, 1/4 SAE ZINC				

REVISED 02/06/18

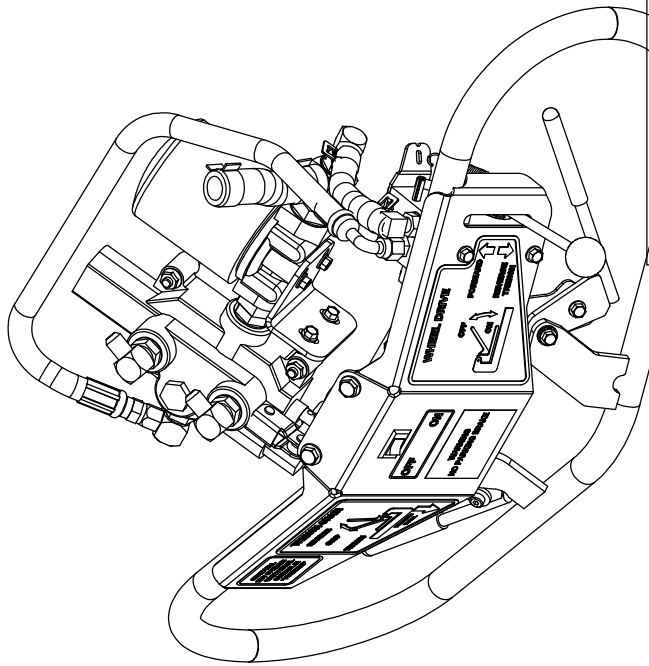
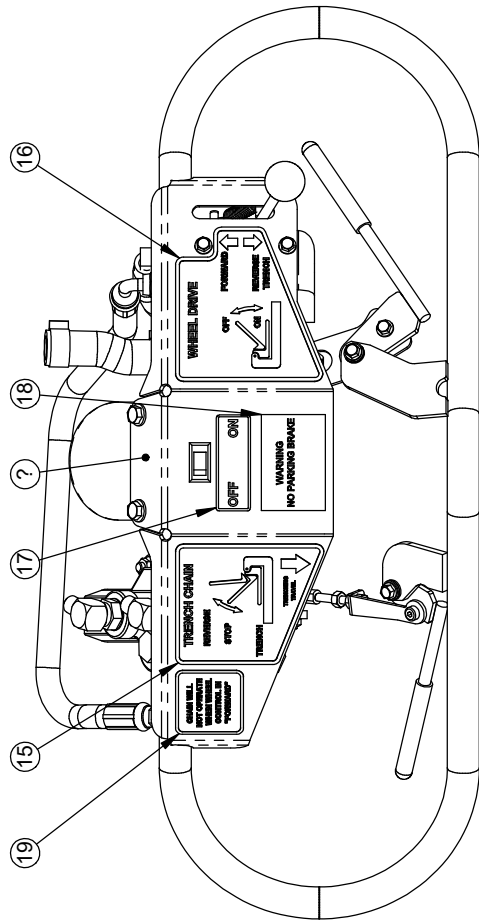

TITLE: CONTROL ASSEMBLY

PRODUCT LINE: 712 WD

SCALE: 1:6

SHEET 1 OF 2

DATE: 09/09

DWG# 00474 WD

**BARRETO**

LEVER DETAILS

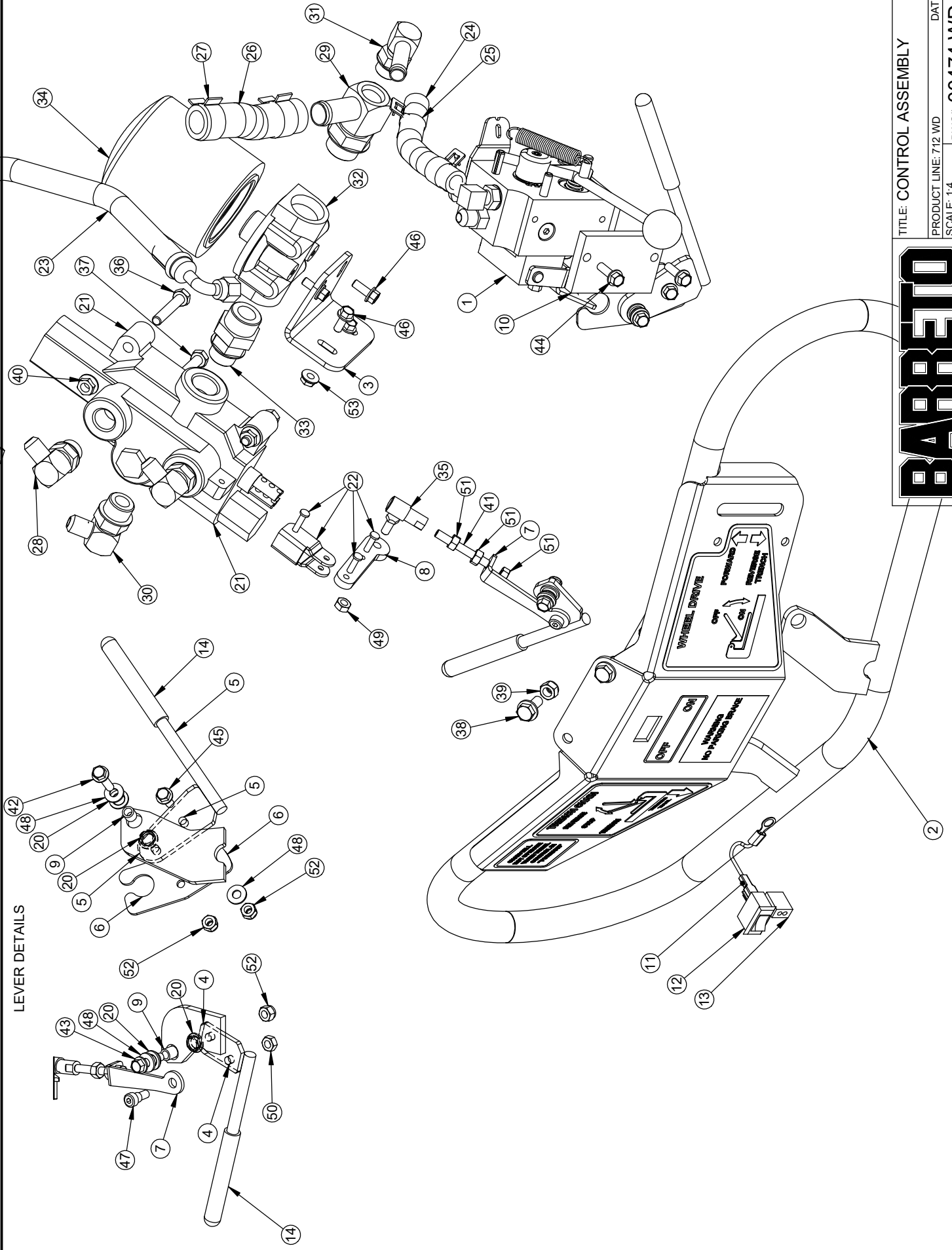

TITLE: CONTROL ASSEMBLY

PRODUCT LINE: 712 WD DATE: 09/09

SCALE: 1:4 DWG#: 00474 WD

SHEET 2 OF 2

**BARRETO**

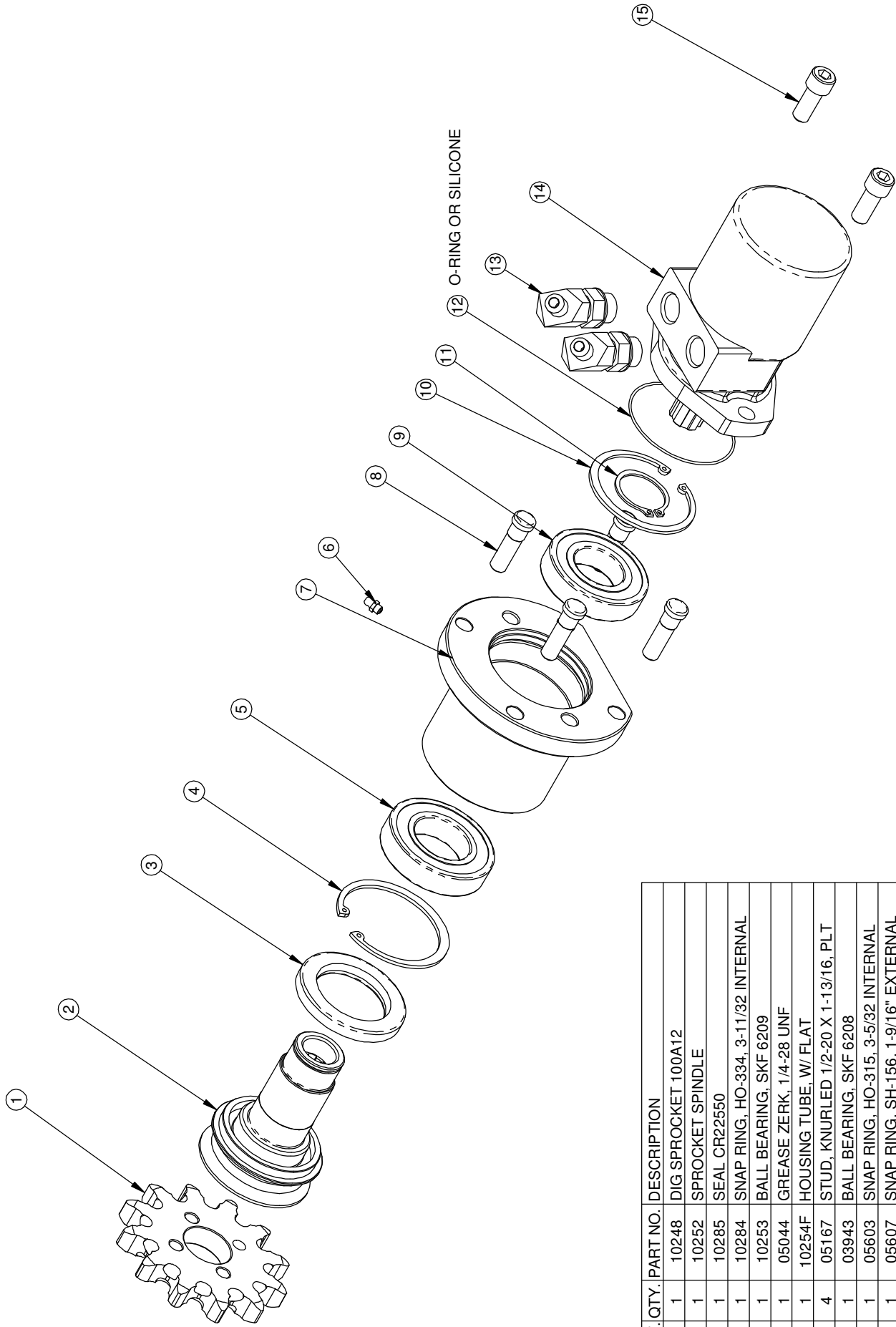

12 O-RING OR SILICONE

# BARRETO

TITLE: CHAIN DRIVE

PRODUCT LINE: 712 TRENCHER DATE: 7/28/09

SCALE: 1:4 SHEET 1 OF 1 DWG# 00473

REF. QTY.	PART NO.	DESCRIPTION
1	10248	DIG SPROCKET 100A12
2	10252	SPROCKET SPINDLE
3	10285	SEAL CR22550
4	10284	SNAP RING, HO-334, 3-11/32 INTERNAL
5	10253	BALL BEARING, SKF 6209
6	05044	GREASE ZERK, 1/4-28 UNF
7	10254F	HOUSING TUBE, W/ FLAT
8	05167	STUD, KNURLED 1/2-20 X 1-13/16, PLT
9	03943	BALL BEARING, SKF 6208
10	05603	SNAP RING, HO-315, 3-5/32 INTERNAL
11	05607	SNAP RING, SH-156, 1-9/16" EXTERNAL
12	10689	O-RING, 2-042, 3-3/8 OD X 1/16 SECTION
13	10406	FITTING, 6802-6-10
14	11992	MOTOR, PARKER TB 0130, 8.0 CI
15	05585	SH CAP SCREW, 1/2-13 NC X 1-1/4 ZINC



1 PN 07013: 6HP ROBIN ENGINE OPTION

REF. QTY.	PART NO.	DESCRIPTION
1	07015	ENGINE, 6.5 HP HONDA GX200
2	11907	ENGINE MOUNT
3	10770M R1	PUMP ADAPTER
4	12057	MTE PUMP
5	05196	KEY, 3/16 X 3/16 X 3/4
6	11002	JAW COUPLER, 3/4" BORE, L075
7	11996	SPIDER, URATHANE, L075
8	11003	JAW COUPLER, 1/2" BORE, L075
9	11186	SHOCK MOUNT, ESTCO MM311C76
10	11074	FITTING, 6802-6-6
11	04218	FITTING, 6802-4-4
12	04202	FITTING, 4601-12-12
13	04231	FITTING, 6410-10-12
14	05294	HH CAP SCREW, 5/16-18 NC X 1-1/2 G5 ZINC
15	05315	HH CAP SCREW, 5/16-18 NC X 1 G5 ZINC
16	05052	HH CAP SCREW, 5/16-24 NF X 3/4 G5 ZINC
17	05068	WASHER, 5/16 SAE ZINC
18	05273	NUT, NYLOCK, 5/16-18 NC ZINC
19	05364	NUT, 5/16-18 NC, SERRATED FLANGE, ZN

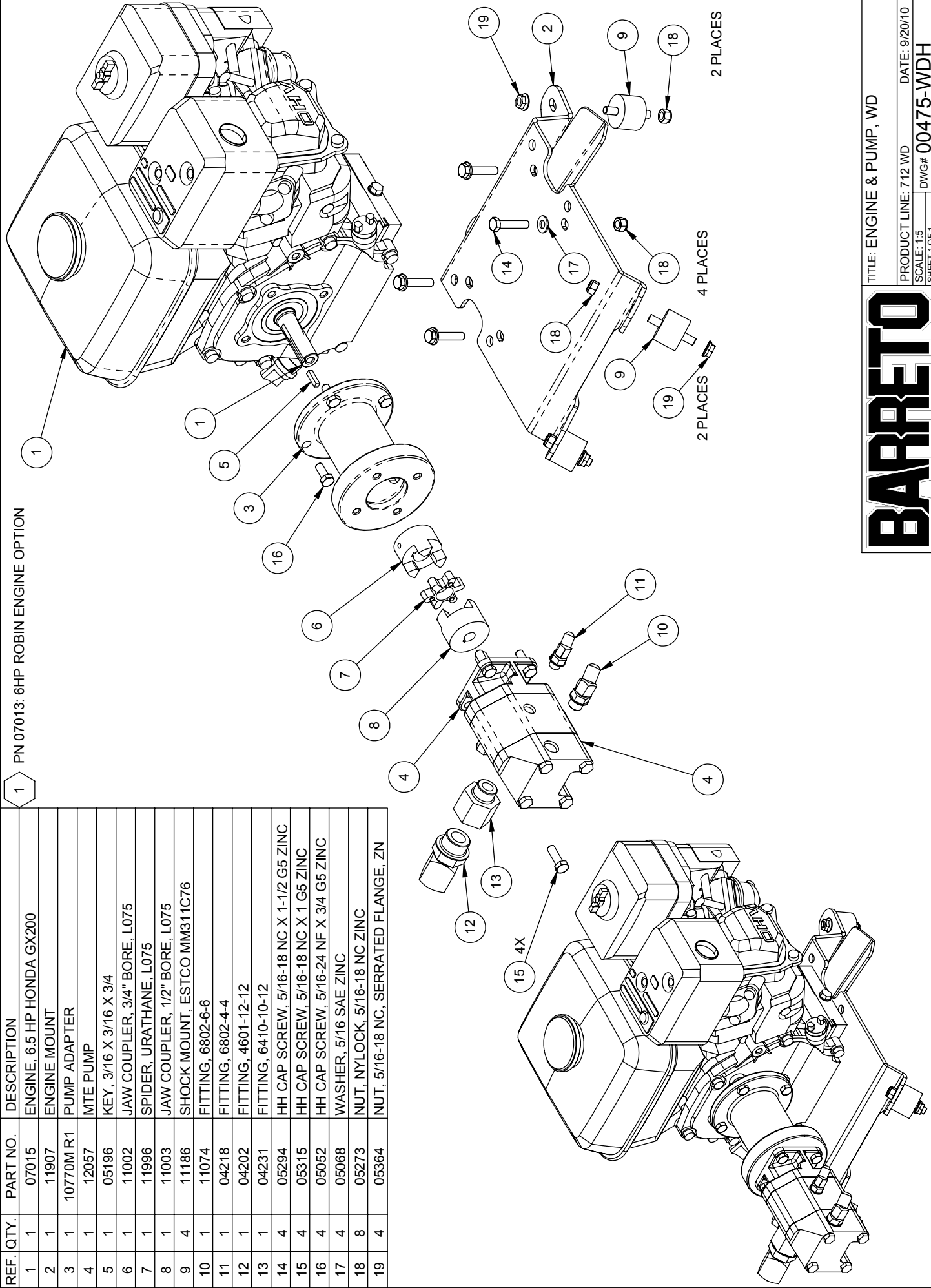

TITLE: ENGINE & PUMP, WD

PRODUCT LINE: 712 WD DATE: 9/20/10

SCALE: 1:5 DWG# 00475-WDH

SHEET 1 OF 1

**18" BOOM : 10649**  
**18" CHAIN GUARD: 11966-18**

ITEM NO.	QTY.	PART NO.	DESCRIPTION
1	1	00265	ROLLER ASSEMBLY
2	1	CHAIN	DIG CHAIN (CALL FOR OPTIONS)
3	1	10316	BOOM - 12"
4	1	11966	CHAIN GUARD
5	1	00473	CHAIN DRIVE
6	1	11895	MOTOR HOUSING
7	1	10287	AUGER
8	1	10286	AUGER SPACER
9	1	10270	CUSHION, BOOM
10	1	10318	BOOM CUSHION WASHER
11	1	11906 R1	PIVOT PIN
12	2	12855	TAPER BUSHING
13	1	10931	DEFLECTOR KEEPER
14	1	12051	CHAIN FLAP
15	2	03269	BUSHING, IGUS LFI-1618-16
16	1	10319	CHAIN TENSION SCREW
17	2	05300-01	HH CAP SCREW, 1/2-13 NC X 1-1/2 G5 ZINC
18	1	05323	HH CAP SCREW, 1/2-13 NC X 1-1/4 G5 ZINC
19	1	05083	WASHER, 7/16 USS ZINC
20	2	10326	NUT, 1/2-13 NC G5 ZINC
21	4	05075	NUT, NYLOCK, 1/2-20 NF ZINC
22	4	10568	HH CAP SCREW, 3/8-24 NF X 3 G5 ZINC
23	3	05182	WHIZ LOCK, 5/16-18 NC X 1-1/4 G8 ZINC
24	3	05273	NUT, NYLOCK, 5/16-18 NC ZINC
25	2	05237	HH CAP SCREW, 1/4-20 NC X 1 G5 ZINC
26	2	05096	NUT, NYLOCK, 1/4-20 NC ZINC
27	3	04440-02	DECAL; DANGER, BOOM GUARD

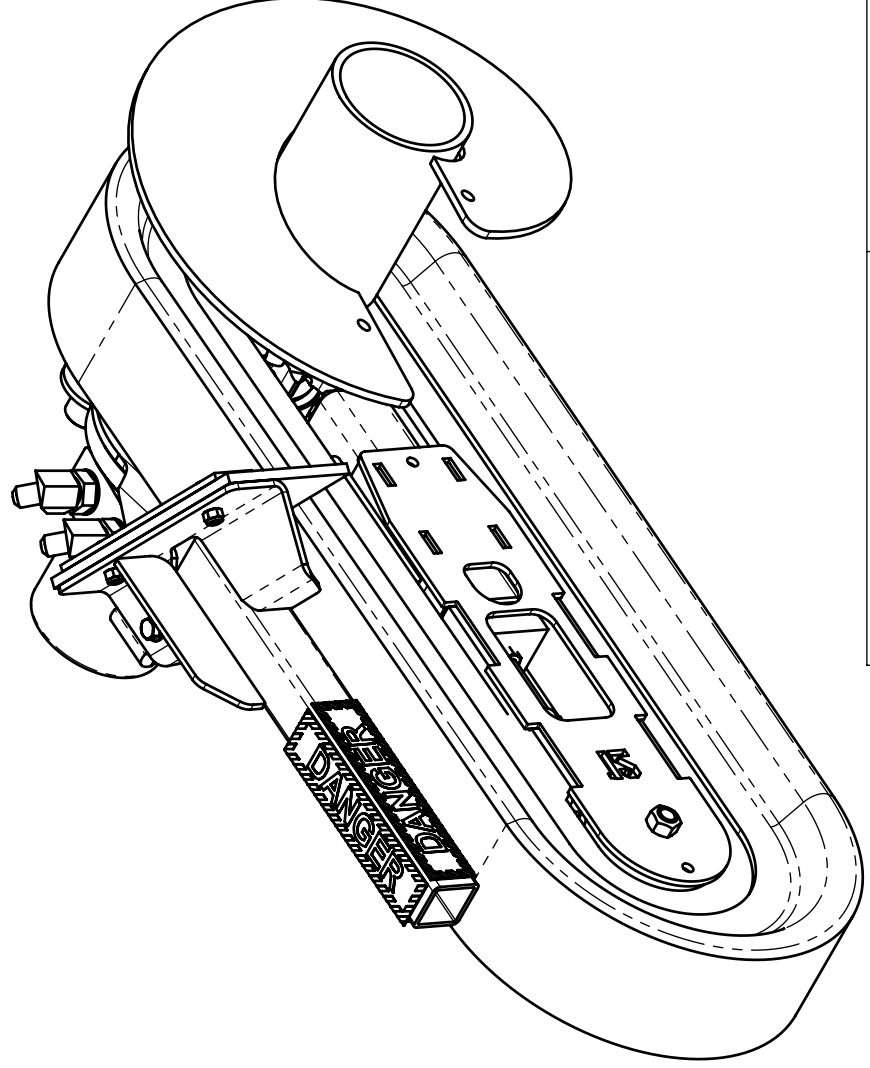

**BARRETO**

TITLE: FRONT END  
 WITH TAPER BUSHING PIVOT  
 PRODUCT LINE: 712 TRENCHER DATE: 9/20/10  
 SCALE: 1:5  
 SHEET 1 OF 2 DWG# 00476 R1

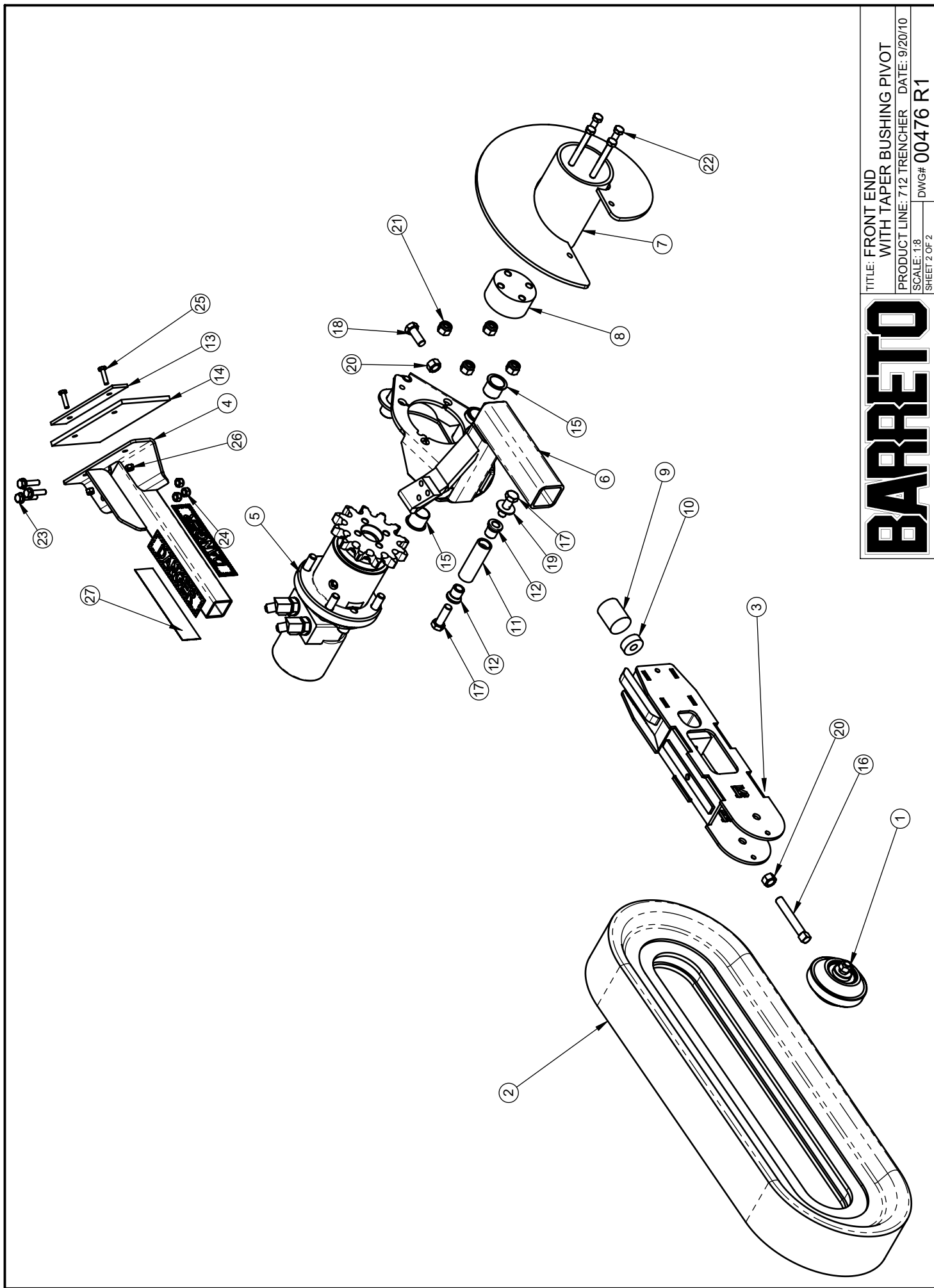

# BARRETO

TITLE: FRONT END  
WITH TAPER BUSHING PIVOT  
PRODUCT LINE: 712 TRENCHER DATE: 9/20/10  
SCALE: 1:8  
SHEET 2 OF 2  
DWG# 00476 R1

RELEASE DATE	11/2010
REVISED DATE	9/8/16
REVISION #	2

ITEM NO.	QTY.	PART NO.	DESCRIPTION
1	1	00256 R1	FREE WHEELING HUB & WHEEL, SET RH & LH
2	1	12001-LH	DRIVE FRAME
3	1	12000	DRIVE AXLE
4	1	12133	WEIGHTS
5	1	12006R	CHAIN COVER
6	1	12128	SPROCKET SPACER
7	1	12052B	C-BALANCE MANIFOLD, SDC10-3S
8	1	12111	MOTOR, PARKER TB 0260, 15.9 CI
9	2	03300	FITTING, 6409-4 PLUG
10	1	04405-712	C-BALANCE CARTRIDGE, CB10-HV
11	1	02015	SPROCKET, #50 11 TOOTH
12	1	12005	SPROCKET, #50 28 T, 1-1/8 BORE, 50BS28
13	1	12007	CHAIN W/ MASTER LINK, #50, 40L, 25"
14	2	03306	BEARING WITH COLLAR, 1.125, RA102RRB
15	4	03283-01	BEARING FLANGE, 03283 IS A SET OF 2
16	4	05364	NUT, 5/16-18 NC, SERRATED FLANGE, ZN
17	7	05606	SNAP RING, 1-1/8" EXTERNAL
18	3	05018	KEY, 1/4 X 1/4 X 1-1/4 HARDENED
19	2	05044	GREASE ZERK, 1/4-28 UNF
20	8	05059	HH CAP SCREW, 3/8-16 NC X 1 G5 ZINC
21	2	10598	HH CAP SCREW, 3/8-16 NC X 3-1/4 G5 ZINC
22	4	05101	WASHER, 3/8 SAE ZINC
23	4	05103	WASHER, 3/8 A325 HARDENED ZINC
24	6	05073	NUT, NYLOCK, 3/8-16 NC ZINC
25	4	05387	HHFS 5/16-18 X 2, G5, ZN
26	4	05144	WHIZ-LOCK 5/16 - 18 X 1
27	1	05069	WHIZ-LOCK 1/4 - 20 X 5/8
28	3	05051	WHIZ-LOCK 1/4 - 20 X 1/2
29	1	105545	WASHER, 1/4 X 1 1/4 ZN

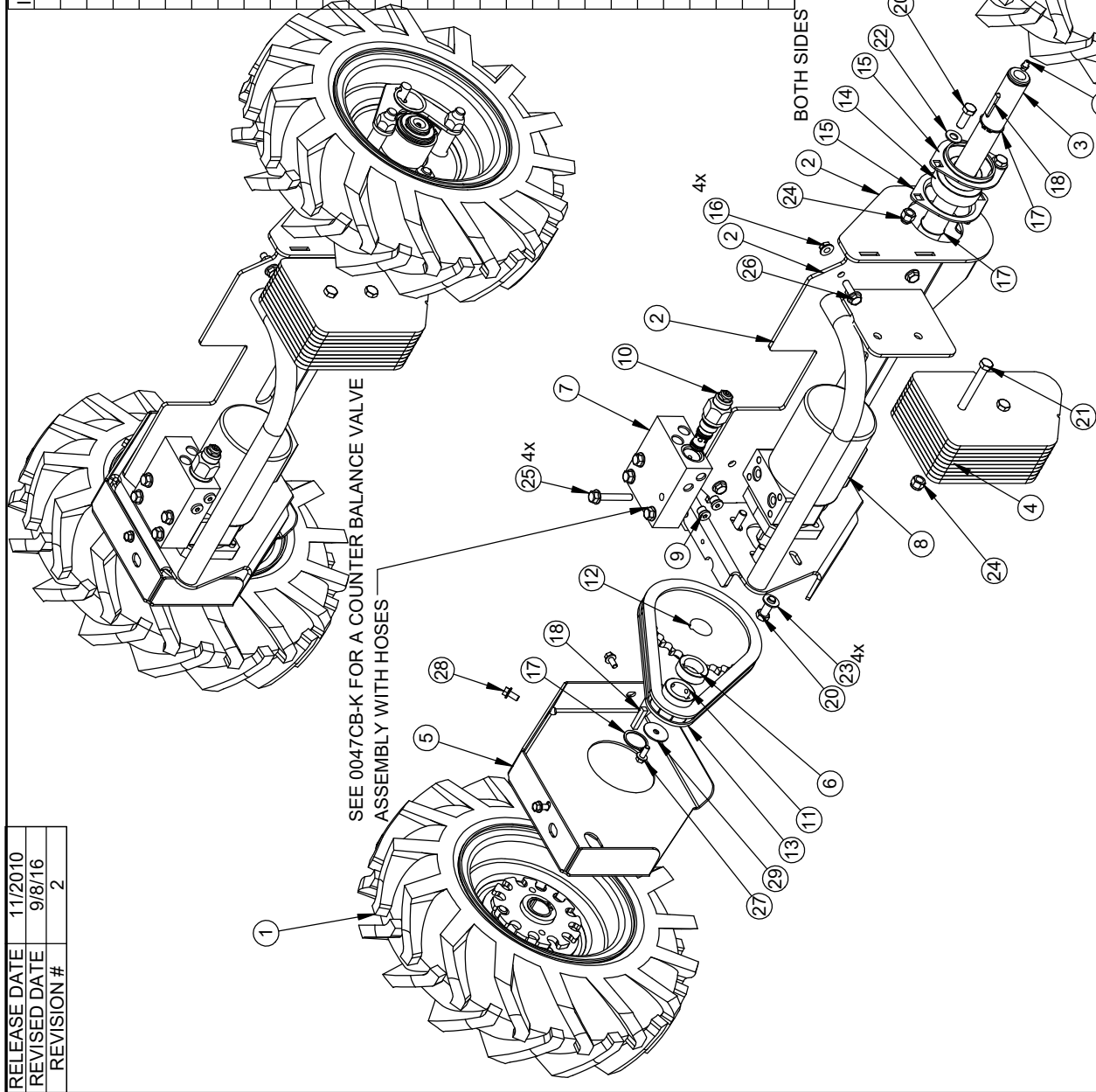

# BARRETO

TITLE: WHEEL DRIVE
PRODUCT LINE: 712
SCALE: 1:8
SHEET 1 OF 1
DWG# 00477 WD

REF	QTY.	PART NO.	DESCRIPTION	REF	QTY.	PART NO.	DESCRIPTION
1	1	12022-PS	VALVE BLOCK	22	1	04560	FITTING, 6400-4-4
2	1	12023	SPOOL, FWD / REVERSE	23	1	11074	FITTING, 6802-6-6
3	1	12024	PUSH SPOOL	24	3	10401	FITTING, 6400-6-6
4	1	12013	WHEEL CONTROL	25	1	11070	FITTING, 4601-8-6
5	1	12015	SPRING STOP	26	4	05051	WHIZ-LOCK 1/4 - 20 X 1/2
6	1	12016	SPRING EYE	27	2	12113	WHIZ-LOCK 1/4 - 20 X 1-1/2
7	1	12021	LEVER				
8	1	12053	PIVOT BLOCK				
9	1	03026	KNOB, 5/16-NC				
10	1	12056	SPRING CENTURY 80717S				
11	2	05200	ROLL PIN (SLOTTED SPRING), 1/4 X 1-1/4 ZINC				
12	1	05143	SET SCREW .25 NF X .25 CUP				
13	2	05010	SNAP RING, 1" EXTERNAL				
14	2	03025	BACK-UP RING, 1" TEFLON				
15	2	03002	O-RING, 2-210, 1" OD X 1/8 SECTION				
16	1	05158	CLEVIS PIN, 1/4 X 3 ZINC				
17	2	03029-04	BUSHING, MICRO PLASTICS 12SWS1048				
18	1	05038	RUE RING COTTER #8				
19	1	12086	SPRING, LEE LC-067GH-12M				
20	2	12085	QUAD RING, Q-4120-N70				
21	3	03300	FITTING, 6409-4 PLUG				

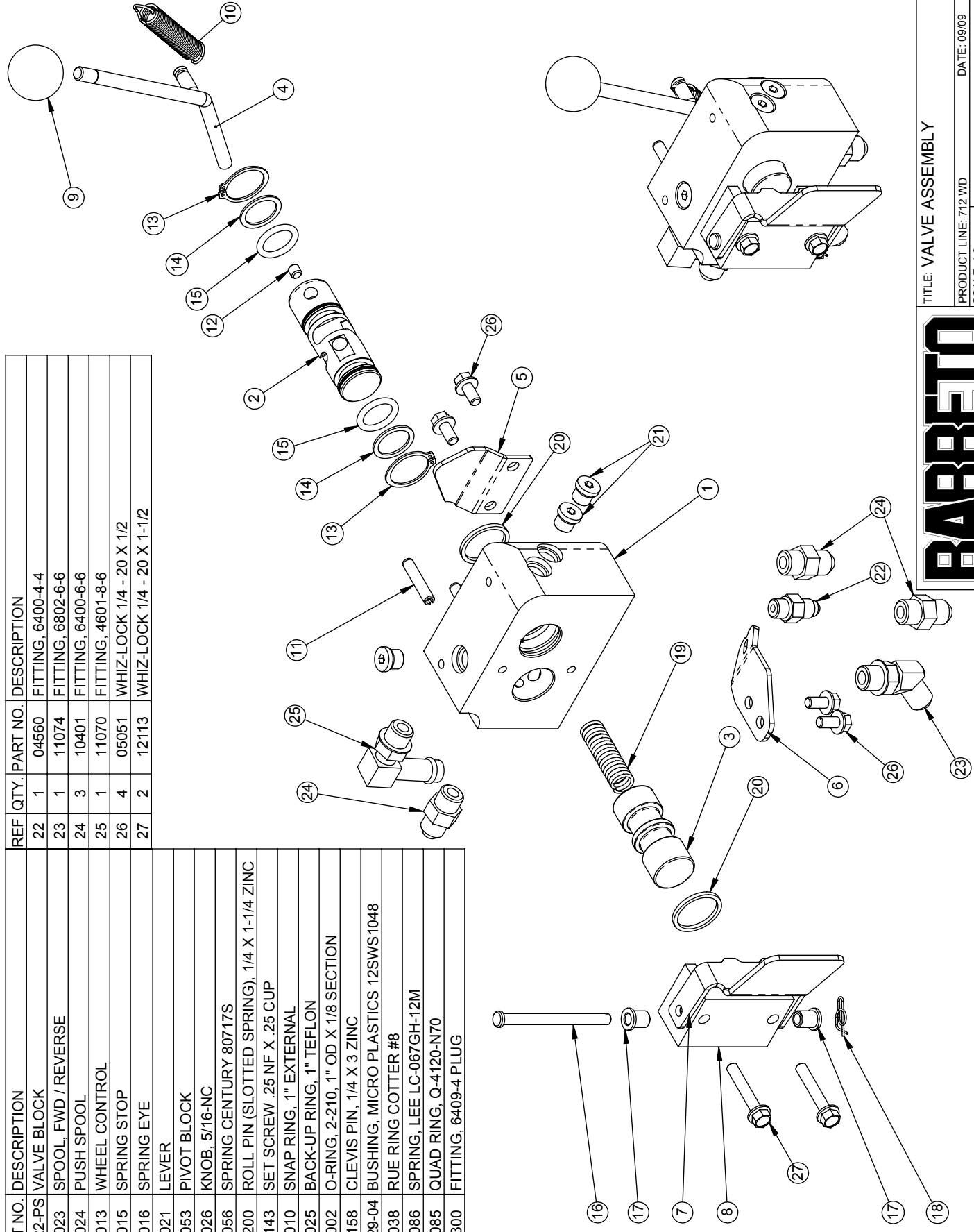

# BARRETO

TITLE: VALVE ASSEMBLY

PRODUCT LINE: 712 WD      DATE: 09/09

SCALE: 1:3      DWG# 00480-PS

SHEET 1 OF 1

ITEM NO.	QTY.	PART NO.	DESCRIPTION
1	1	00472	BODY
2	1	00474 WD	CONTROLS, W/ WHEEL DRIVE
3	1	00475-WDH	ENGINE & PUMP, WD
4	1	00476 R1	FRONT END
5	1	00477 WD	WHEEL DRIVE
6	1	11986	ENGINE GUARD
7	1	12096	SHIELD
8	1	11908	SHIELD SPACER
9	1	11983	TUBE CLAMP, 5/8"
10	1	11967	HOSE, UNLOADER TEE / VALVE, 3/8
11	1	11968	HOSE, CH. VALVE TO CH. MOTOR
12	1	11969	HOSE, CH. VALVE TO CH. MOTOR
13	1	11990	HOSE, SEQ. 3 / WHEEL MOTOR B
14	1	11990	HOSE, UNLOADER / W. MOTOR, REAR
15	1	12027	HOSE, PUMP / DRIVE VALVE, 1/4"
16	1	12028	HOSE, PUMP / UNLOADER EL, 3/8
17	1	12029	HOSE, VALVE / UNLOADER, RIGHT
18	1	12029	HOSE, VALVE / UNLOADER, LEFT
19	1	05054	HH CAP SCREW, 5/16-18 NC X 1-3/4 G5 ZINC
20	6	05131	HHFS 5/16-18 X 3/4, G8, ZN
21	1	05541	WASHER, 5/16 FENDER ZINC
22	7	05364	NUT, 5/16-18 NC, SERRATED FLANGE, ZN

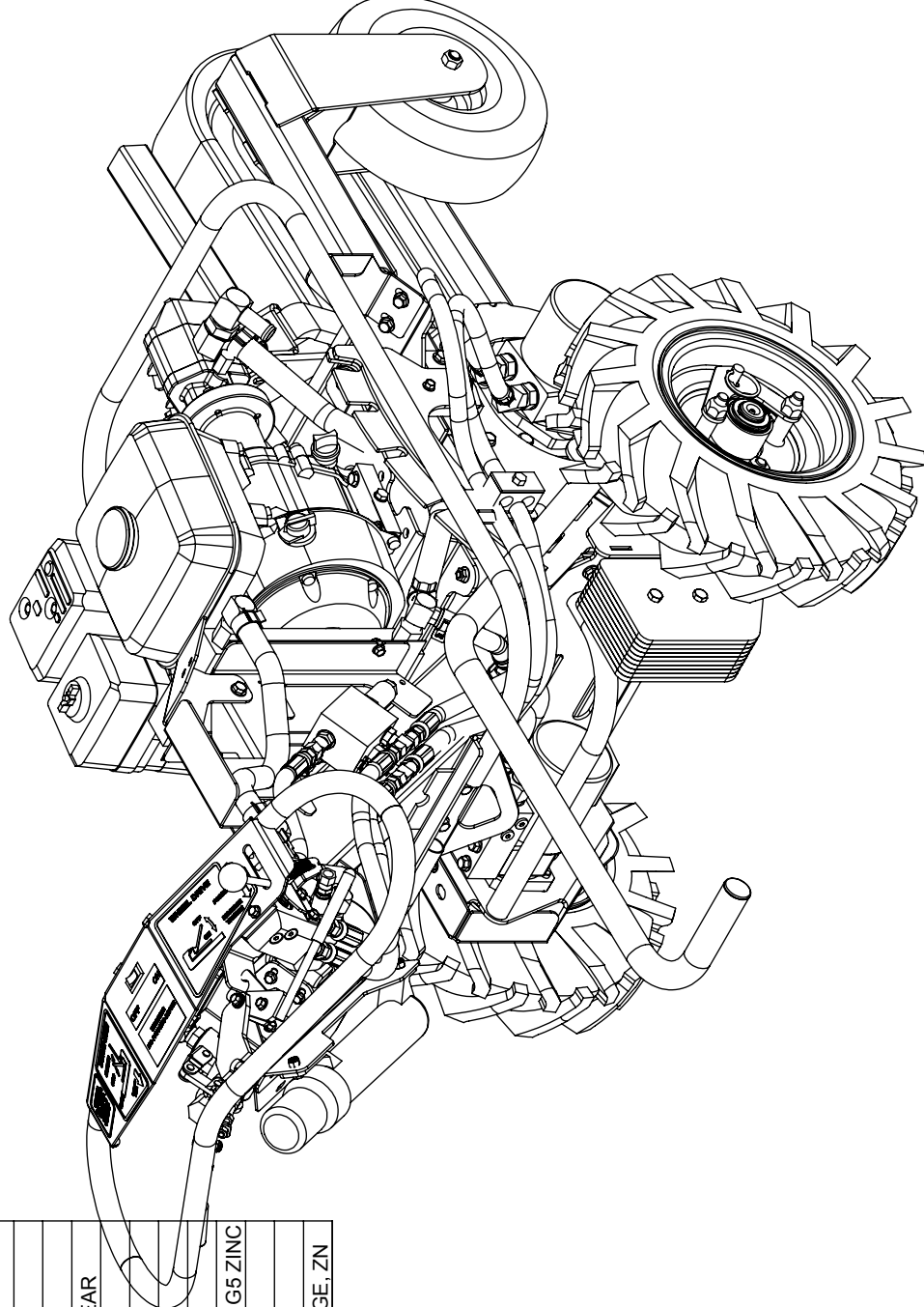

RELEASE DATE	9/21/10
REVISED DATE	6/28/16
REVISION #	0

TITLE: 712 TRENCHER

**BARRETO**

PRODUCT LINE: 712 TRENCHER

SCALE: 1:8

SHEET 1 OF 2

DWG# 712 WD

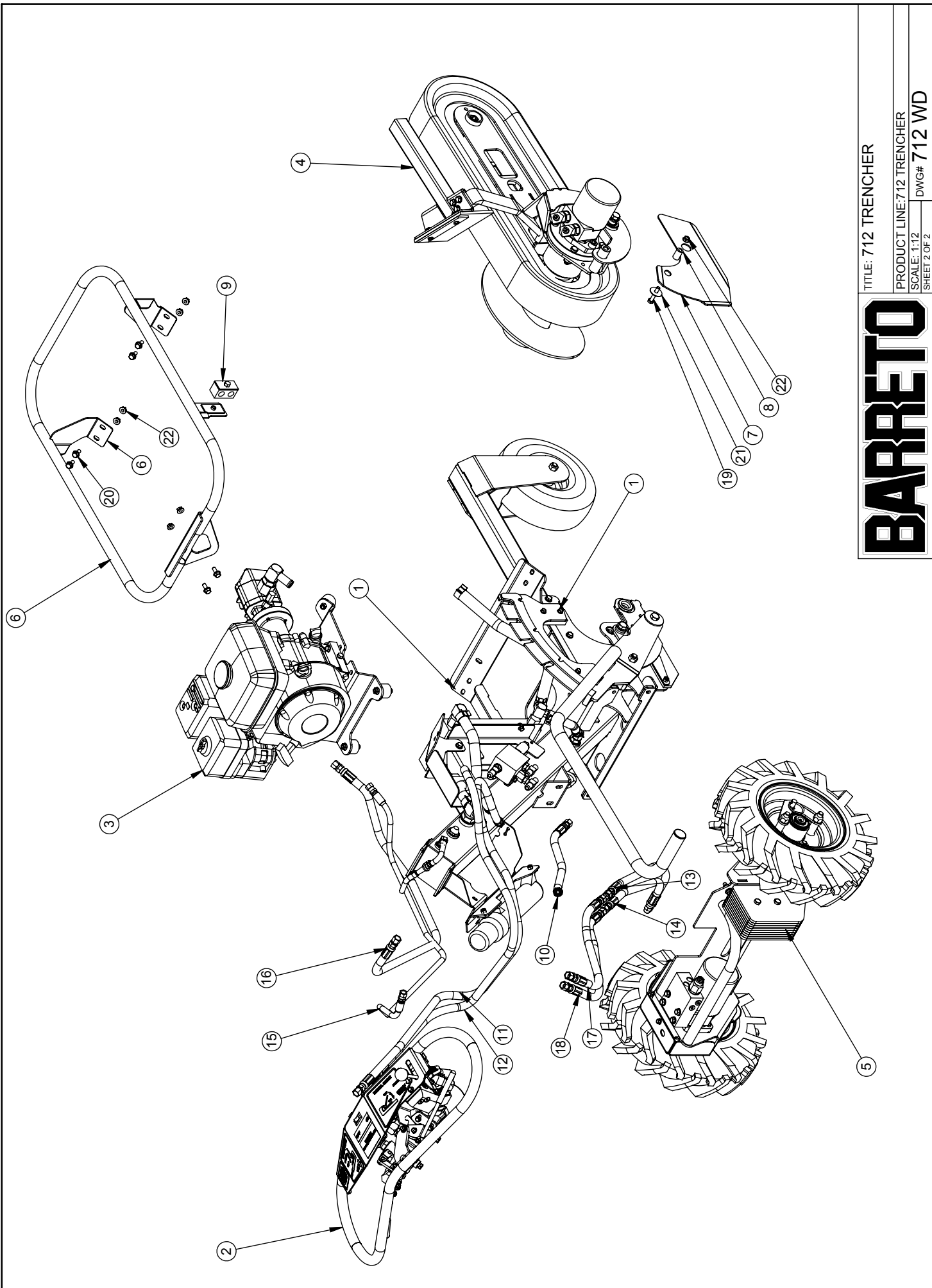

TITLE: 712 TRENCHER

PRODUCT LINE: 712 TRENCHER

SCALE: 1:12

DWG# 712 WD

SHEET 2 OF 2

# BARRETO

REF	QTY.	PART NO.	DESCRIPTION
1	1	12081	VALVE BLOCK
2	1	4602	UNLOADER VALVE, CP240-2
3	2	10409	FITTING, 6803-6-6-6
4	1	12047	FITTING, 6410-6-6
5	1	04228	FITTING, 6804-6-6-6
6	2	05069	WHIZ LOCK, 1/4-20 NC X 5/8 ZINC

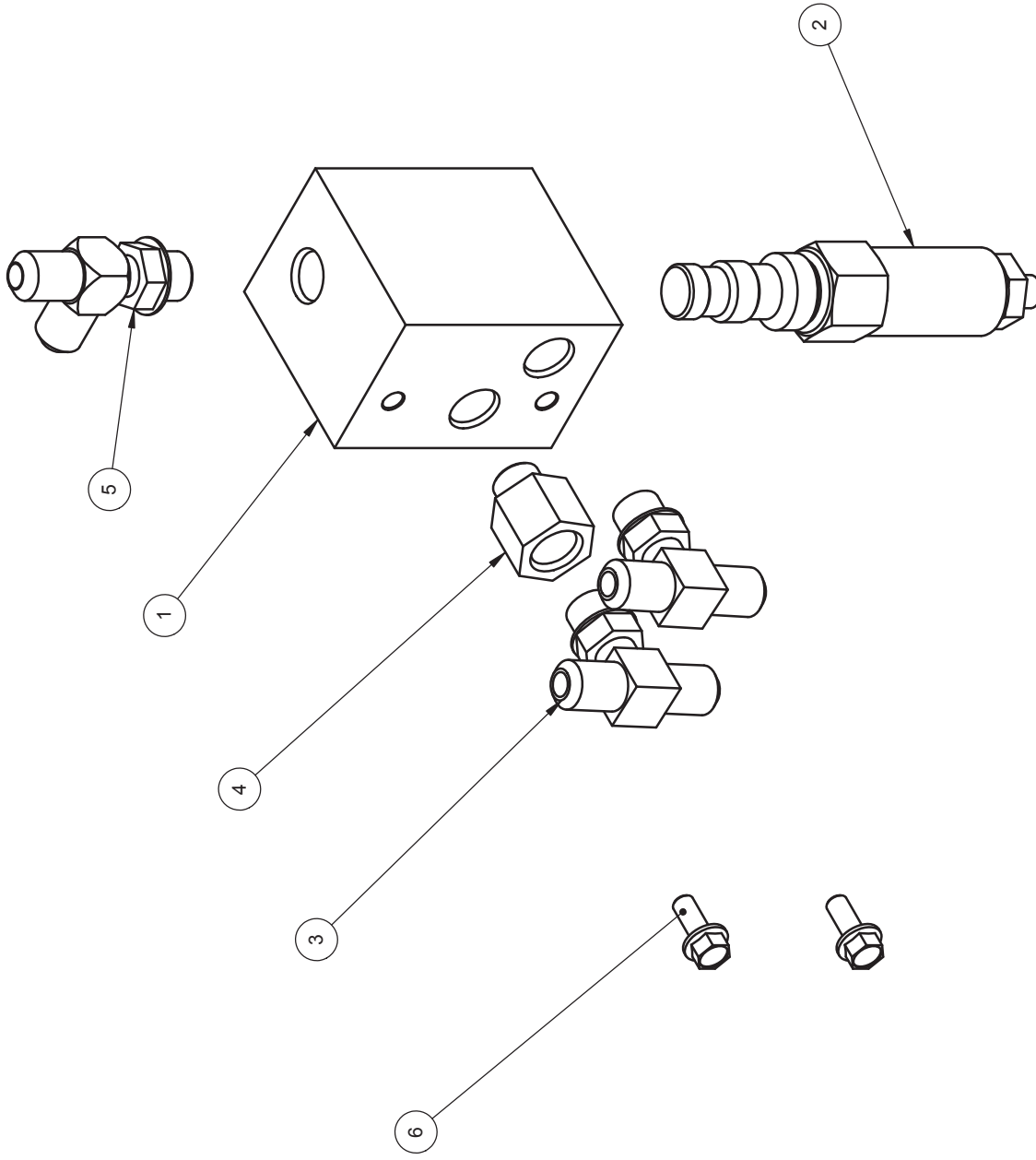

TITLE: UNLOADER VALVE

PRODUCT LINE: 712 WD DATE: 9/29/10

SCALE: 1:2 DWG# 00481

SHEET 1 OF 1





## WHEEL DRIVE UNLOADER ADJUSTMENT

THE 712MT IS EQUIPPED WITH AN UNLOADER VALVE WHICH CONTROLS THE WHEEL SPEED WHILE THE MACHINE IS TRENCHING. THIS VALVE IS LOCATED ON THE RIGHT SIDE OF THE MACHINE, BEHIND THE ENGINE.

IF THE WHEELS SPIN EXCESSIVELY, THE UNLOADER VALVE IS SET TOO HIGH. LOOSEN LOCK NUT AND TURN ADJUSTER SCREW OUT 1/2 TURN. TIGHTEN LOCK NUT AND TRENCH TEST MACHINE. REPEAT ADJUSTMENT IF WHEEL SPIN CONTINUES TO OCCUR.

IF THE MACHINE PROGRESSES TOO SLOWLY WHEN TRENCHING AND THERE IS NO WHEEL SPIN, THE UNLOADER VALVE IS SET TOO LOW. LOOSEN LOCK NUT AND TURN ADJUSTER SCREW IN 1/4 TO 1/2 TURN. TIGHTEN LOCK NUT AND TRENCH TEST MACHINE. REPEAT ADJUSTMENT IF NECESSARY.

THE UNLOADER VALVE SHOULD BE ADJUSTED SO THERE IS MINIMAL WHEEL SPIN, AND THE ENGINE IS WORKED, BUT NOT OVERLOADED.

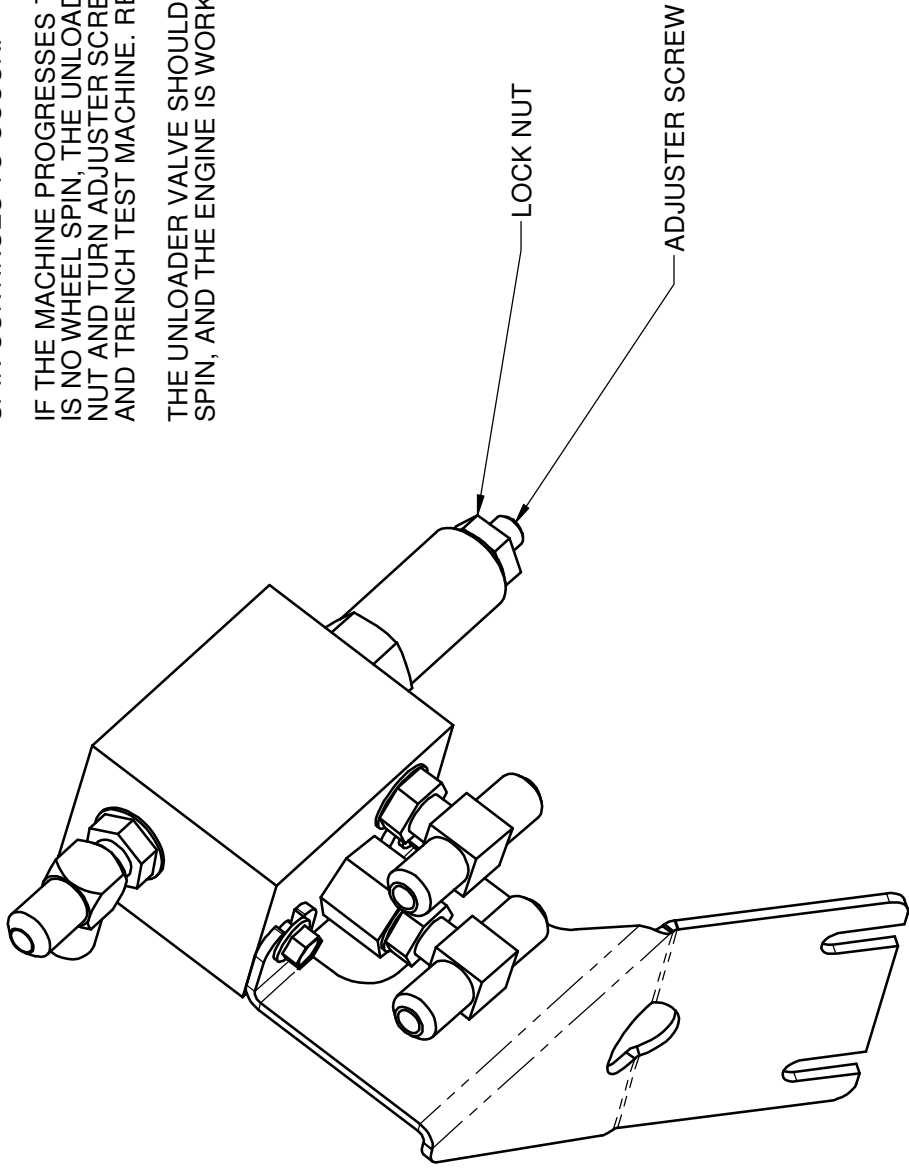

ITEM NO.	QTY.	PART NO.	DESCRIPTION
1	1	12052B	C-BALANCE MANIFOLD, SDC10-3S
2	1	04405-712	C-BALANCE CARTRIDGE, CB10-HV
3	1	11990	HOSE, UNLOADER / W. MOTOR, REAR
4	1	11990	HOSE, SEQ. 3 / WHEEL MOTOR B
5	2	03300	FITTING, 6409-4 PLUG
6	2	03225	O-RING, 2-116N70, 15-16 OD X 3/32 SEC
7	4	05387	HHFS 5/16-18 X 2, G5, ZN

RELEASE DATE	9/7/16
REVISED DATE	NEW
REVISION #	0

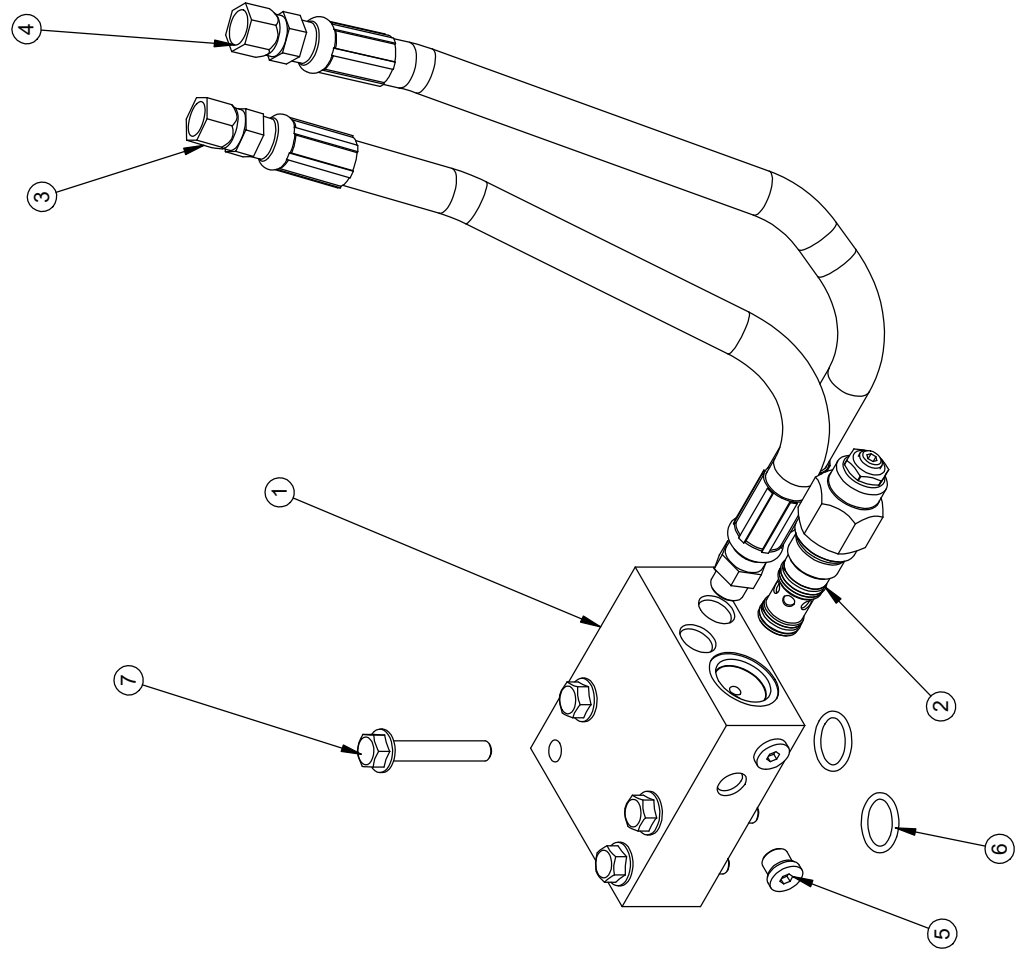
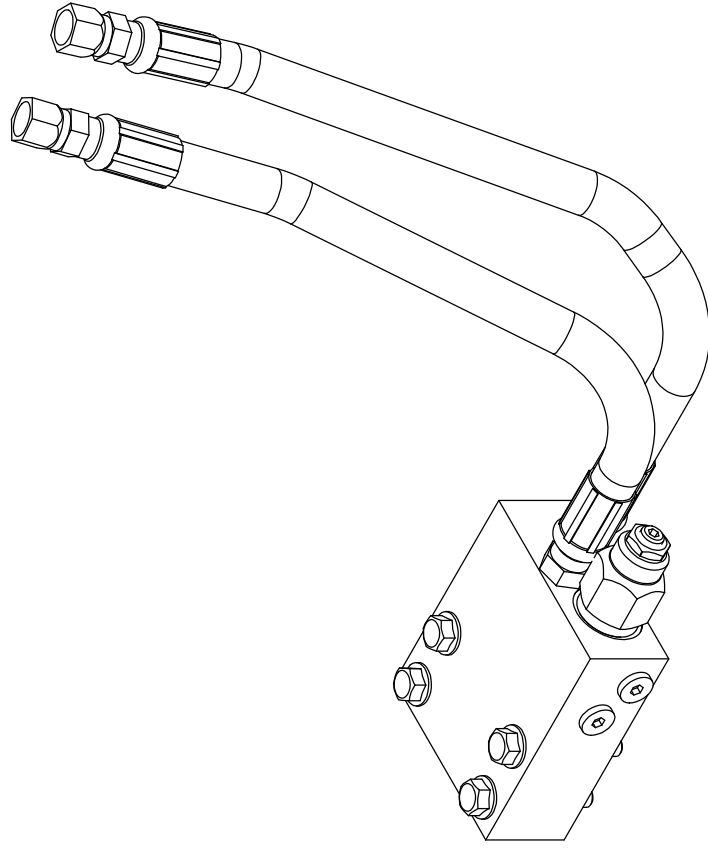

# BARRETO

TITLE:	712 COUNTER BALANCE VALVE KIT
PRODUCT LINE:	712 (UPS KIT)
SCALE:	1:3
SHEET:	1 OF 1
DWG#	0047CB-K

ITEM NO.	PART NUMBER	DESCRIPTION	QTY.
1	03626-B	BARE CHAIN, 1.25 PITCH, 52 LINK	1
2	03632-L	SHARK TOOTH, LEFT, 1.25" P	13
3	03632-R	SHARK TOOTH, RIGHT, 1.25" P	13
4	11008	PLATE SPACER, 1.06"	52
5	05281	HH CAP SCREW, 3/8-24 NF X 2-1/4 G8 PLAIN	52
6	05283	NUT, GRIPCO, 3/8-24 NF G8 ZINC	52
7	03519	CONNECTING PIN ( COTTER INCLUDED)	1

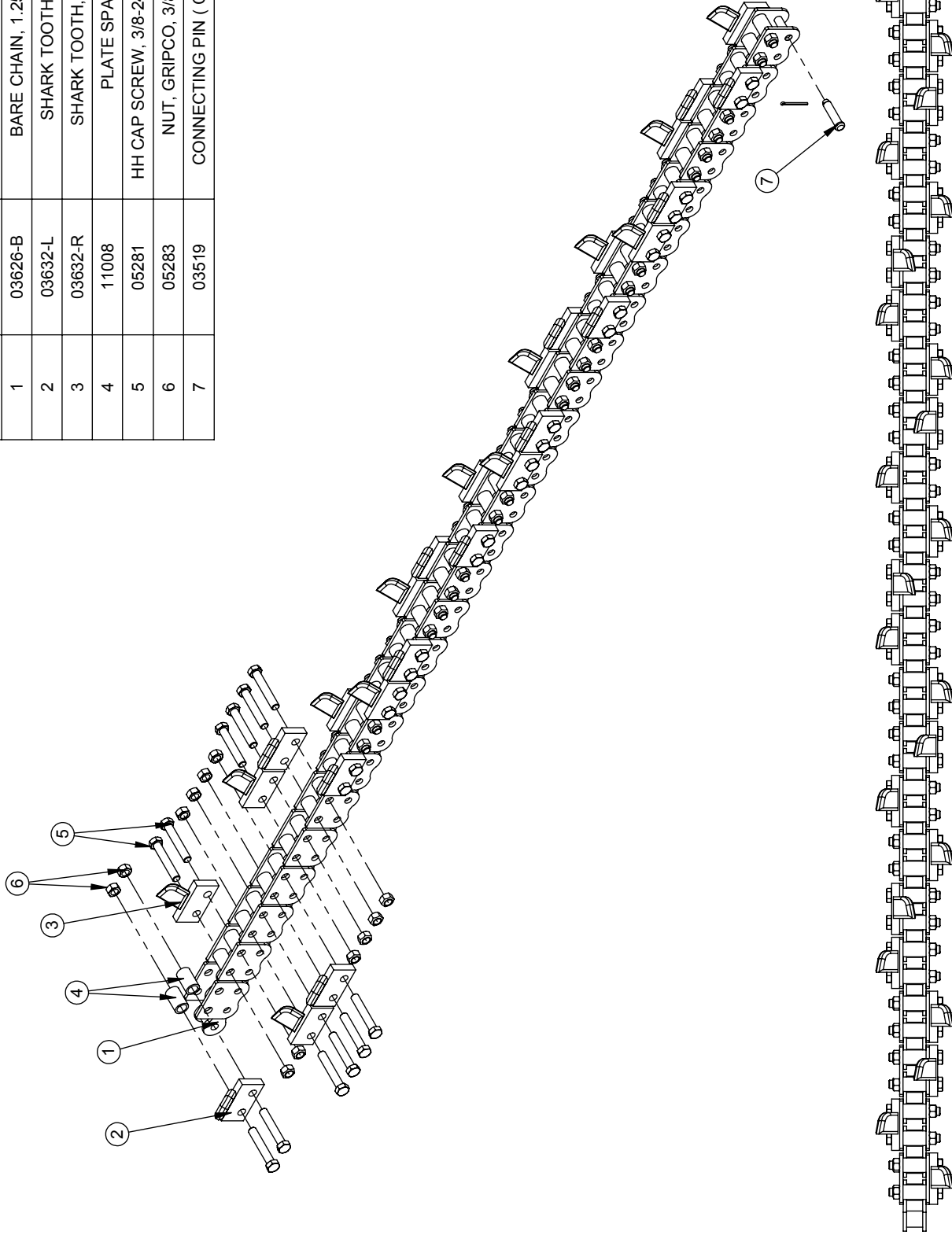

ESTIMATED SHIPPING WEIGHT: 40 LBS

# BARRETO

TITLE: CHAIN, 18" 26 STA 4" SHARKBOLT

PRODUCT LINE: TRENCHERS 912, 712 DATE: 03/20/2014

SCALE: 1:7

SHEET 1 OF 1 DWG# 03626-4SB



## 712/912 TRENCHER CHAIN TYPES / DESCRIPTIONS

### **STANDARD CUP CHAIN** (AKA Skip Tooth)

This chain has a cup tooth on every other link.

#### **Where to use it**

This chain is most effective in loamy soil - soil that is packable into clods. It is also more effective in clay or "gumbo" soil that is sticky and clings to the chain. The space between the cups allows the soil to let go instead of running around with the chain as a slurry which prevents effective digging.



### **DOUBLE CUP CHAIN**

This chain has a cup tooth on every link.

#### **Where to use it**

This chain is best for sand and dry, loose soil that has a tendency to fall back into the trench. The extra cups provide for better clean-out.



### **COMBO/SHARK CHAIN**

This chain has an alternating pattern of cup and Shark teeth.

#### **Where to use it.**

Use this chain in pretty much the same conditions as the standard combo chain. Although not as aggressive, the Shark teeth last longer and do not fall off. This is our most popular chain.



### **SHARK CHAIN**

The teeth on this chain are all Shark teeth that are welded onto the chain. Replacement teeth are not available for this chain.

#### **Where to use it.**

This chain can be used in the most adverse soils. It is good in rocky soil, "cliché", limestone, hard-pan and any other hard to dig soils. It does not clean out well in sandy or dry, loose, loamy soil. This is not the fastest but it is the most durable chain available. It is not uncommon for the teeth to outlast the chain rollers. When the rollers wear out, the complete chain must be replaced.



### **BOLT-ON SHARK CHAIN**

This chain utilizes a standard chain blank and has Shark teeth that are bolted to the chain blank.

#### **Where to use it.**

This chain is good in all the conditions described for the Shark chain. The advantage is the teeth can be removed when the chain wears out and can be used on a new blank. It is not uncommon for the teeth to last through two chains.



**NOTE: The 712 trencher chains are available in 12" & 18" lengths and 4" & 5" widths. The 912 chains are available in 12", 18", & 24" lengths and 4" & 6" widths.**