

THE
BARRETO
MODEL E916/918
Y-SERIES HYDRAULIC REAR TINE TILLER
EXPLODED VIEWS WITH PART NUMBERS

CONGRATULATIONS!

You are now the proud owner of the BARRETO Y-Series 916/918 tiller. The following pages have detailed views of your tiller, along with corresponding part numbers. If you have any questions or need any replacement parts in the future, please contact us at your convenience. Our toll-free phone number, fax and email are listed below and parts may be ordered through any of these methods.

Thank you for your patronage and confidence in BARRETO equipment.

Barreto Manufacturing, Inc.
Innovative Equipment Engineered to Last
66498 Highway 203
La Grande, OR 97850
1-800-525-7348
1-541-963-6755 Fax
E-Mail: info@barretomfg.com
Parts: parts@barretomfg.com
Web Site: <http://www.barretomfg.com>

Machine Identification Record

BARRETO Customer number _____

Machine model number _____

Machine serial number _____

Engine manufacturer _____

Engine model number _____

Engine serial number _____

REF	QTY.	PART NO.	DESCRIPTION	REF	QTY.	PART NO.	DESCRIPTION
1	1	11279	TINE SHAFT	48	1	10146	SIDE PLATE, RH TINE SECTION
2	16	05061	HH CAP SCREW, 7/16-20 NF X 1 G8 ZINC	49	1	05059	HH CAP SCREW, 3/8-16 NC X 1 G5 ZINC
3	8	05063	HH CAP SCREW, 7/16-20 NF X 1-1/4 G8 ZINC	50	1	05083	WASHER, 7/16 USS ZINC
4	12	03196 R1	TINE, REVERSIBLE	51	2	05103	WASHER, 3/8 A325 HARDENED ZINC
5	1	11278	TINE MOTOR HUB, SPLINED	52	1	10144	OUTBOARD BEARING ASSEMBLY
6	24	05074	NUT, 7/16-20 NF G8 ZINC	53	1	05006	ROLL PIN (SLOTTED SPRING), 3/8 X 1-1/2 ZINC
7	1	03930	SEAL, CR 19763	54	1	01012	DEPTH BAR
8	14	05071	NUT, NYLOCK, 5/16-24 NF ZINC				
9	1	01067	TINE MOTOR MOUNT & LH SIDE PLATE				
10	14	05052	HH CAP SCREW, 5/16-24 NF X 3/4 G5 ZINC				
11	2	03040-04	DECAL, "GREASE DAILY"				
12	1	05282	PIPE NIPPLE, 1/8" X 5 LONG				
13	1	05204	PIPE COUPLER, 1/8"				
14	1	05256	GREASE ZERK, 1/8 NPT				
15	1	05607	SNAP RING, SH-156, 1-9/16" EXTERNAL				
16	2	05585	SH CAP SCREW, 1/2-13 NC X 1-1/4 G5 ZINC				
17	1	03001	O-RING, 2-152, 3-7/16 OD X 3/32 SECTION				
18	1	04605-F	TINE MOTOR				
19	2	03926	O-RING, 2-112N90, 11/16 OD X 3/32 SECTION				
20	1	05603	SNAP RING, HO-315, 3-5/32 INTERNAL				
21	1	03943	BALL BEARING, SKF 6208				
22	6	05056	HH CAP SCREW, 3/8-24 NF X 1 G5 ZINC				
23	1	02065	MANIFOLD, TINE MOTOR				
24	4	05361	SH CAP SCREW, 5/16-18 NC X 7/8 ZINC				
25	2	04520	FITTING, 6400-8-8				
26	2	03302	FITTING, 6409-6 PLUG				
27	6	05072	NUT, NYLOCK, 3/8-24 NF ZINC				
28	1	10702	TORQUE TUBE, 17" BOLT ON				
29	4	05046	NUT, GRIPCO, 1/2-13 NC G5 ZINC				
30	4	05067	HH CAP SCREW, 1/2-13 NC X 1 G5 ZINC				
31	1	10067	TINE COVER, 916				
32	1	03341-22	DECAL, "TILLER OPERATING INSTRUCTIONS"				
33	1	03341-23	DECAL, "TILLER SAFETY INSTRUCTIONS"				
34	2	05092	HH CAP SCREW, 3/8-16 NC X 1-1/2 G5 ZINC				
35	2	05073	NUT, NYLOCK, 3/8-16 NC ZINC				
36	1	01099	HANDLE, DEPTH BAR				
37	1	03018	GRIP, 1/8 X 3/4 X 2-3/4				
38	1	03080	SPRING				
39	1	01018	PIN, DEPTH BAR				
40	1	03065	HAIR SPRING COTTER #4				
41	1	03040-02	DECAL, "BARRETO", 3-1/2 X 11-1/4				
42	1	03040-01	DECAL, "MADE IN USA"				
43	1	03040-08	DECAL, "WARNING" (YELLOW)				
44	1	03040-03	DECAL, "CAUTION" (BLACK & WHITE)				
45	1	03040-07	DECAL, "CAUTION" (YELLOW)				
46	1	04340	DECAL, "916"				
47	1	05044	GREASE ZERK, 1/4-28 UNF				

- ① FOR 918, USE PART NO. 10706 (TORQUE TUBE, 19")
- ② FOR 918, USE PART NO. 01066 (TINE COVER, 918)
- ③ FOR 918, USE PART NO. 03040-51 (DECAL, "918")
- ④ FOR 918, USE PART NO. 11281 (TINE SHAFT, 918)
- ⑤ PART NO. 05063-24 IS A SET OF 24 PIECES.
- ⑥ PART NO. 03196 R1-12 IS A SET OF 12 PIECES.
- ⑦ PART NO. 05074-24 IS A SET OF 24 PIECES.
- ⑧ REFERENCE DWG. 10144 FOR INDIVIDUAL PARTS.
- ⑨ 03926, O-RING INCLUDED WITH TINE MOTOR

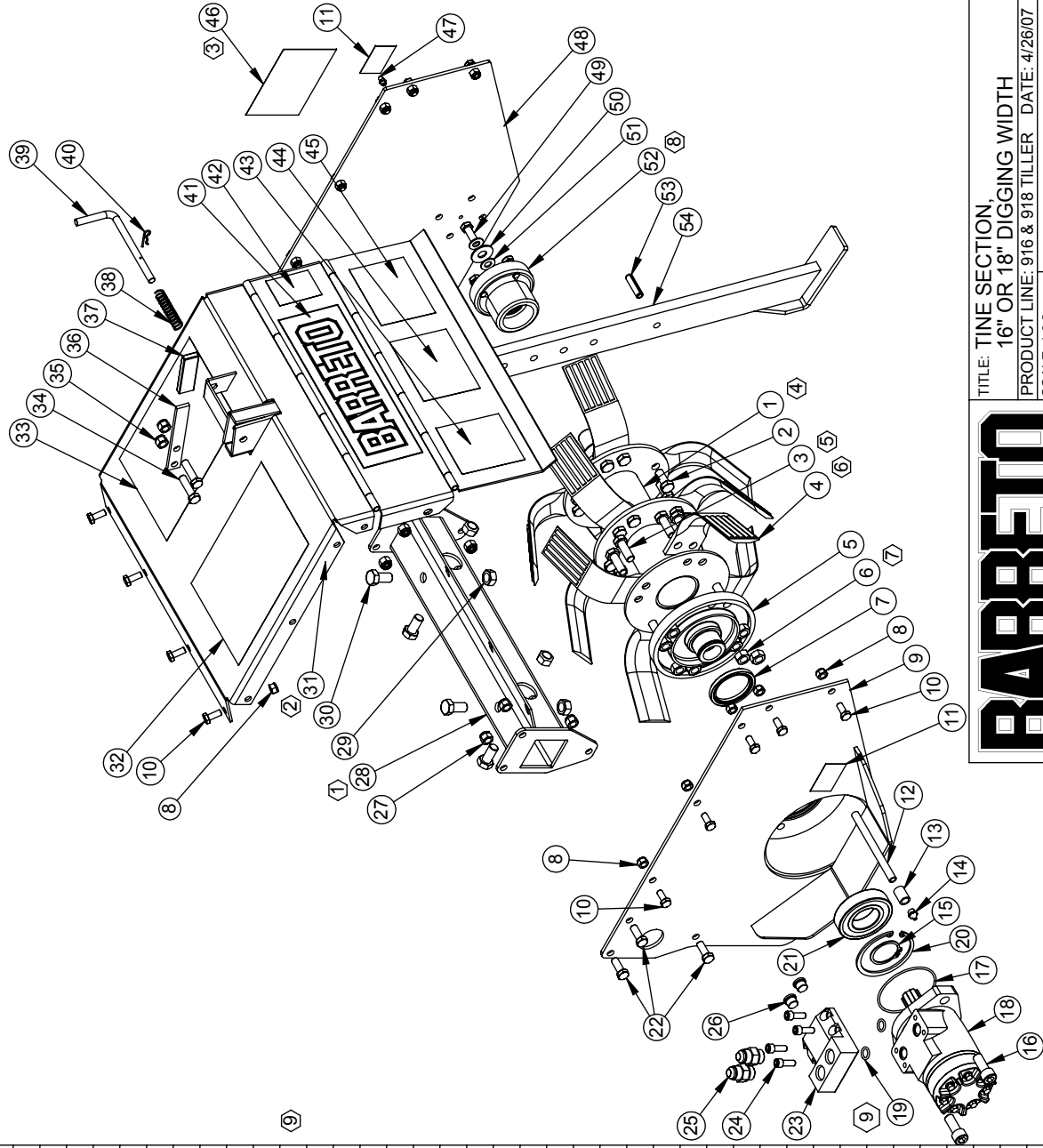

BARRETO

TITLE: TINE SECTION
 16" OR 18" DIGGING WIDTH
 PRODUCT LINE: 916 & 918 TILLER DATE: 4/26/07
 SCALE: 1:9.2
 SHEET 1 OF 1 DWG# 00253 R2

REF QTY.	PART NO.	DESCRIPTION
1	02289-HUB	WHEEL HUB ASSY, 1-1/8" BORE
2	1	03190-FW TIRE & RIM, 16" X 4", LEFT HAND
3	1	03191-FW TIRE & RIM, 16" X 4", RIGHT HAND
4	6	05042 NUT, LUG, 1/2-20 NF
5	2	02068 PIN, FREE WHEELING
6	2	05102 WASHER, 1/2 SAE ZINC HARDENED
7	4	05548 ROLL PIN (SLOTTED SPRING), 1/8 X 3/4 ZINC
8	2	03352 SPRING, CENTURY 3385
9	4	02083 SPACER, WHEEL
10	2	01077 MOUNTING PLATE, PIN, FREE WHEELING
11	2	03550 SPLIT RING-27

1 FOR TRENCHER, 03190-FW IS ON RIGHT SIDE, FOR TRENCHING IN REVERSE

2 FOR TRENCHER, 03191-FW IS ON LEFT SIDE, FOR TRENCHING IN REVERSE

03190-F = FOAM FILLED TIRE, LEFT
03191-F = FOAM FILLED TIRE, RIGHT

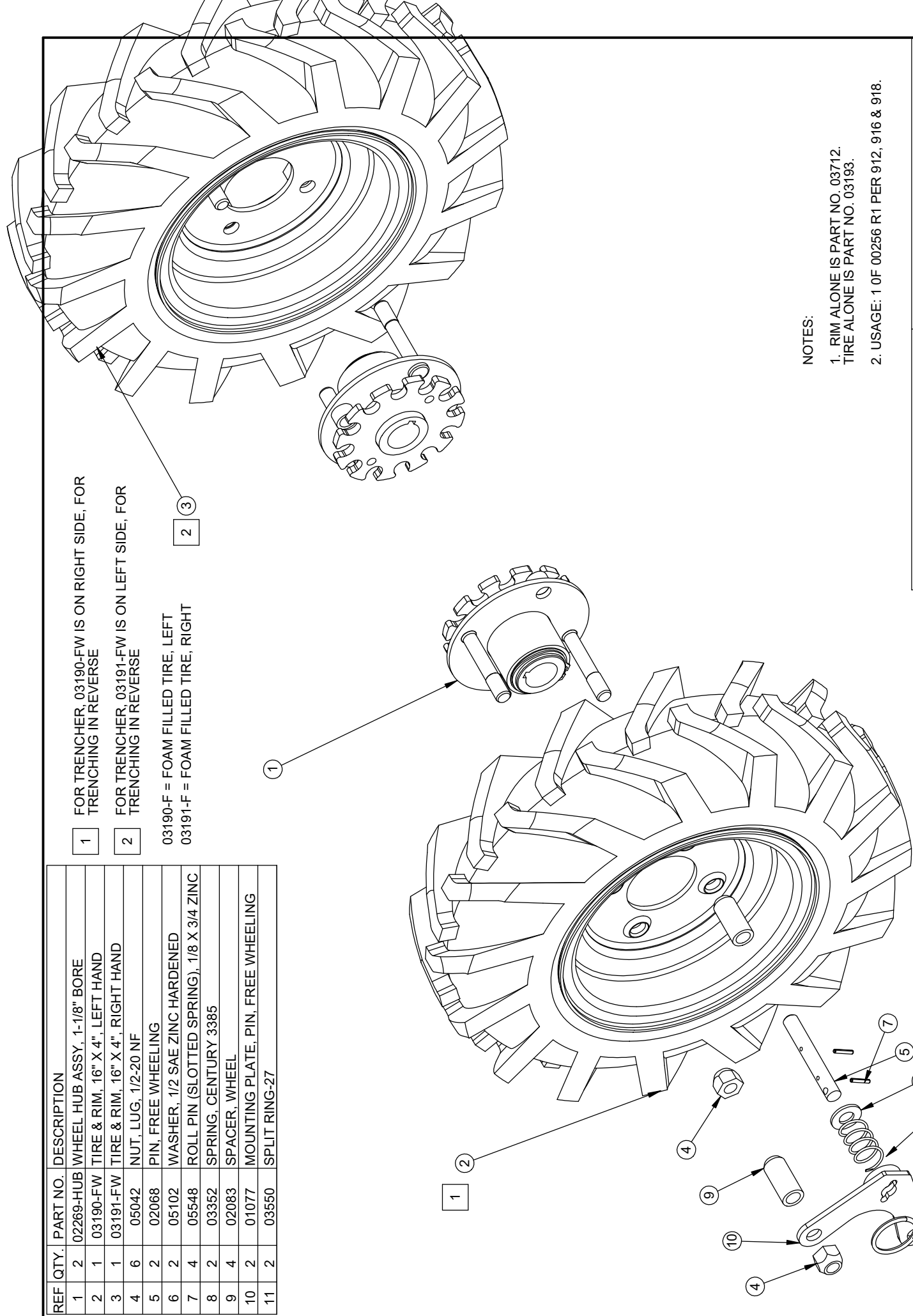

NOTES:

1. RIM ALONE IS PART NO. 03712.
TIRE ALONE IS PART NO. 03193.
2. USAGE: 1 OF 00256 R1 PER 912, 916 & 918.

BARRETO

TITLE: FREE WHEELING HUBS AND WHEELS

PRODUCT LINE: COMMON DATE: 7/16/07
SCALE: 1:4 DWG#: 00256 R1
SHEET 1 OF 1

RELEASE DATE	11/29/2017
REVISED DATE	03/16/2018
REVISION #	1

ITEM NO.	PART NUMBER	DESCRIPTION	QTY.
1	07006	HONDA GX270 ENGINE	1
2	03023	JAW COUPLER, 1" BORE L095	1
3	03022	SPIDER, RUBBER	1
4	05101	WASHER, 3/8 SAE ZINC	14
5	05059	HH CAP SCREW, 3/8-16 NC X 1 G5 ZINC	7
6	05202	HH CAP SCREW, 3/8-24 NF X 3/4 G5 ZINC	1
7	16502	CASAPPA PL10 PUMP 8CC, 2.5CC TANDEM	1
8	02016	PUMP ADAPTER	1
9	16534	ADAPTER, PUMP MOUNT TO CASAPPA PUMP	1
10	16509	JAW COUPLER, 1" BORE L095	1
11	04554	FITTING, 6801-8-8	2
12	05121	HH CAP SCREW, 3/8-16 NC X 1-3/4 G5 ZINC	2
13	05073	NUT, NYLOCK, 3/8-16 NC ZINC	2
14	05092	HH CAP SCREW, 3/8-16 NC X 1-1/2 G5 ZINC	2
15	16571	BOLT PLATE	1
16	16560	PUMP SUCTION HOSE	1
17	05008	CLAMP, 1" HOSE, CTB-29	2
18	16513	SPRING-CENTURY 11141	1
19	04529	FITTING, 6410-8-6	2
20	04231	FITTING, 6410-10-12	1
21	10362	FITTING, 4603-12-12	1

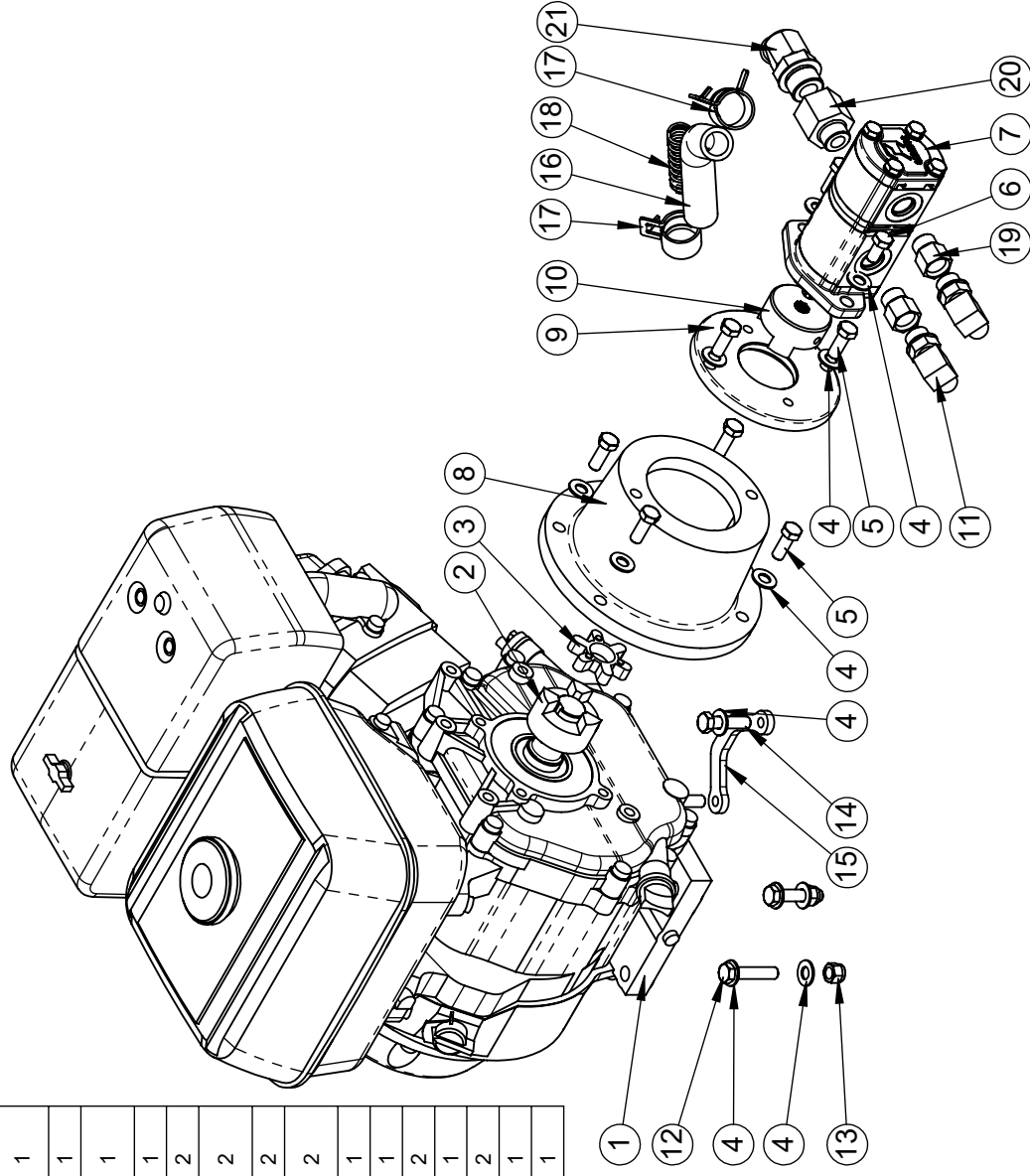

BARRETO

TITLE: 916/918 ENGINE ASSY
PRODUCT LINE:TILLER
SCALE: 1:8
SHEET: 1 OF 2
DWG# 00610

918 TILLER TWO-SPEED DRIVE OPERATION

LOW SPEED (TILLING)- 2.5cc PUMP DRIVES WHEEL MOTOR, 8cc PUMP DRIVE TINE MOTOR
HIGH SPEED- BOTH PUMPS DRIVE WHEEL MOTOR, NO FLOW OR PRESSURE GOING TO TINE MOTOR

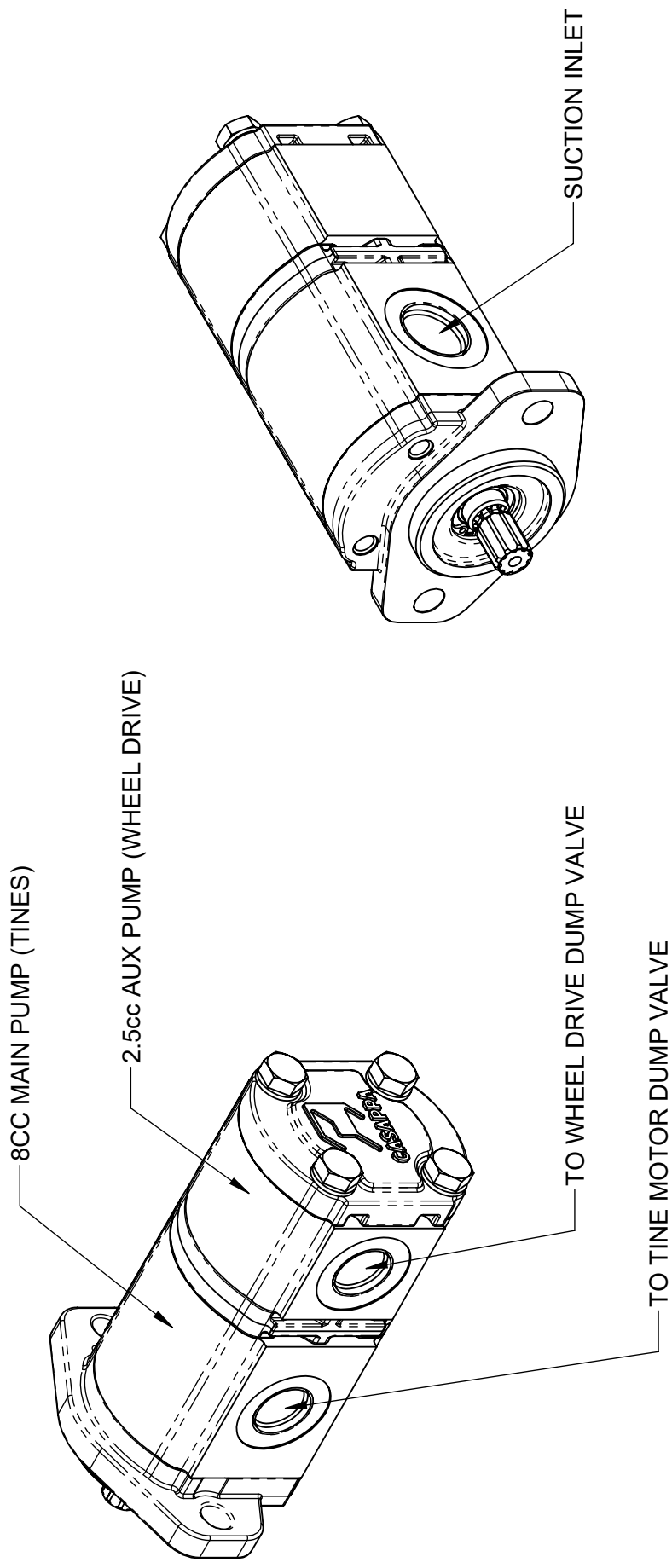

TITLE: CASAPPA PL10 PUMP 8CC, 2.5CC T AND

PRODUCT LINE:TILLER

SCALE: 1:2

SHEET 2 OF 2

DWG# 00610

RELEASE DATE	10/25/2017
REVISED DATE	NEW
REVISION #	0

ITEM NO.	PART NUMBER	DESCRIPTION	QTY.
1	16514	TWIN DUMP VALVE BODY	1
2	10481	RETURN TUBE, #8 O-RING	2
3	04008-DO	RELIEF VALVE, 2750 POUND, O-RING	2
4	04017	FITTING, 6803-8-8-8	2
5	16515	DUMP VALVE SPOOL	2
6	16517	SPOOL LINK	1
7	05351	SHSB, 3/8S X 1/4SL X 5/16 NC, BK OX	2
8	03061	FELT WASHER, 5/8 X 1 X 1/8	1
9	05078	WASHER, 1/4 USS ZINC	1
10	16519	DUMP VALVE PUSH PLATE	1
11	03060	BUSHING, IGUS MFI-1012-06	2
12	16518	TILLER LID	1
13	16520	DUMP VALVE ARM	1
14	16521	O-RING 0.103" DIA X 2.75" ID	1
15	05216	SNAP RING, 3/4 EXTERNAL	2
16	04529	FITTING, 6410-8-6	1
17	05051	WHIZ-LOCK 1/4 - 20 X 1/2	12
18	16516	SPRING- CENTURY A13-69	2
19	03020	SEAL	1

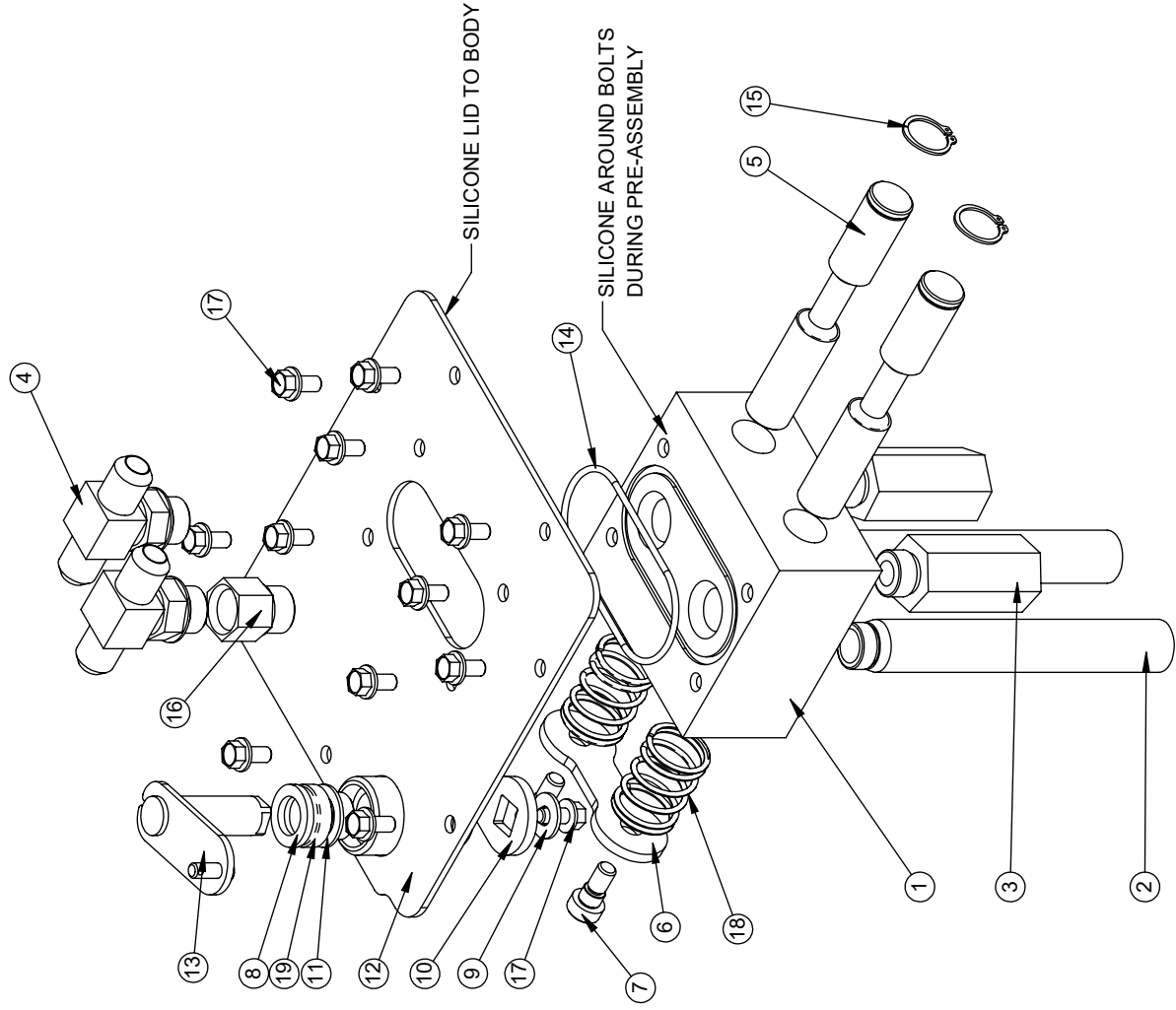

BARRETO

TITLE: DUMP VALVE/LID ASSEMBLY
PRODUCT LINE:TILLER
SCALE: 1:4
SHEET 1 OF 1
DWG# 00612

ITEM NO.	PART NUMBER	DESCRIPTION	QTY.
1	16557	MANIFOLD, WHEEL DRIVE MOTOR	1
2	16556	MOTOR MOUNT	1
3	16508	EATON H-SERIES MOTOR 17.9CI	1
4	05572	SH CAP SCREW, 5/16-18 NC X 1 ZINC	4
5	03926	O-RING, 2-112N90, 11/16 OD X 3/32 SECTION	2
6	03238	O-RING, 2-132, 1-15/16 OD X 3/32 SECTION	1
7	03218	O-RING, 2-012, 1/2 OD X 1/16 SECTION	4
8	10623	O-RING, 2-010, 3/8 OD X 1/16 SECTION	8
9	03302	FITTING, 6409-6 PLUG	2
10	04210	FITTING, 6802-8-8	2
11	05187	HHFS 3/8-16 X 3/4, G5, ZN	4
12	05404	HHFS 1/4-20 X 1, G5, ZN	8
13	16555	O-RING, MOTOR MOUNT	1
14	02014	SPROCKET, #50 10 TOOTH	1

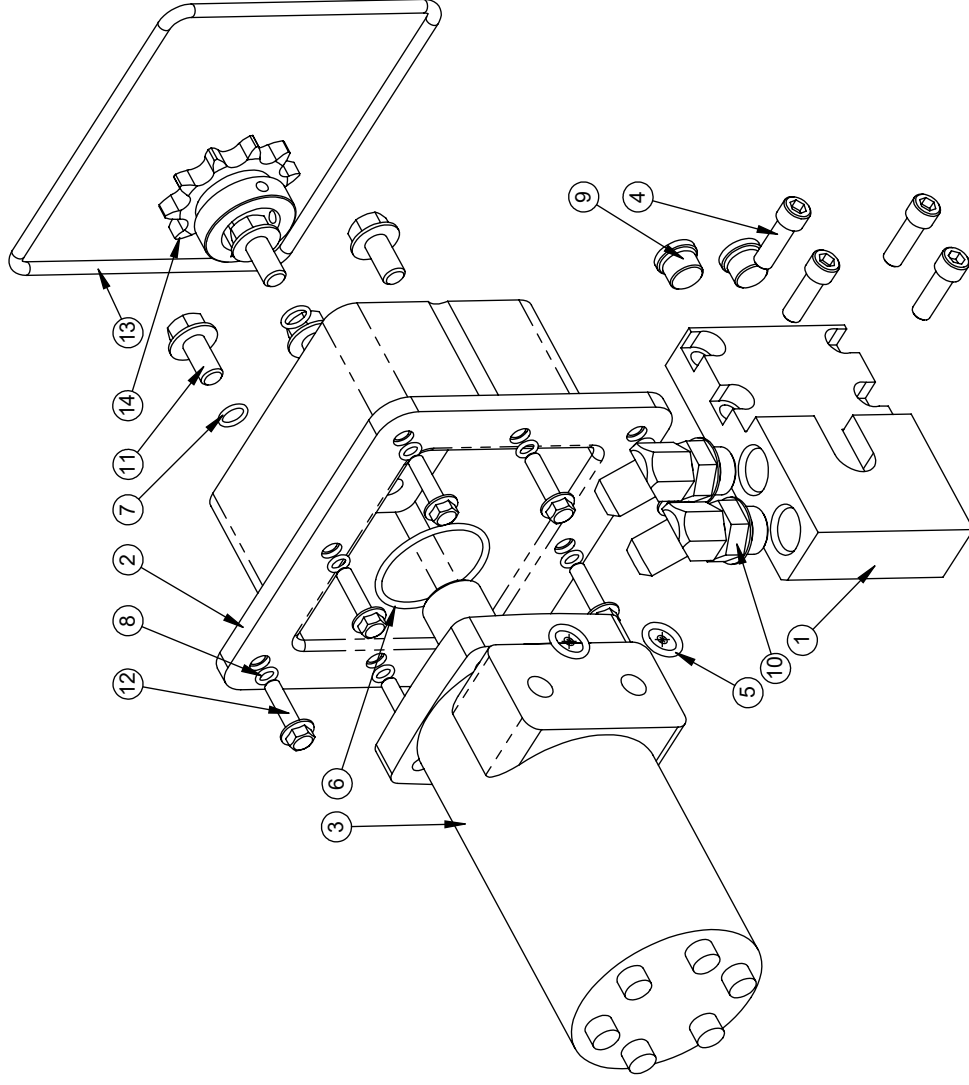

RELEASE DATE	10/25/2017
REVISED DATE	NEW
REVISION #	0

BARRETO

TITLE: DRIVE MOTOR ASSEMBLY

PRODUCT LINE:TILLER

SCALE: 1:4

DWG# 00613

SHEET 1 OF 1

ITEM NO.	PART NUMBER	DESCRIPTION	QTY.
1	16525	TILLER CONTROL BLOCK	1
2	04015-D	VALVE SPOOL, TINES (ORDER 04010-K)	1
3	04520	FITTING, 6400-8-8	4
4	04554	FITTING, 6801-8-8	4
5	04015-C	VALVE SPOOL, WHEEL DRIVE (ORDER 04010-K)	1
6	02017	HANDLE, 5/16 X 7	2
7	03027	DETENT SPRING	2
8	03300	FITTING, 6409-4 PLUG	7
9	05200	ROLL PIN (SLOTTED SPRING), 1/4 X 1-1/4 ZINC	6
10	16528	FLOW DIVIDER LEVER	1
11	03026	KNOB, 5/16-NC	3
12	16529	VALVE SPOOL, SWITCH VALVE	1
13	16530	DETENT BLOCK	1
14	16531	DOWEL-.125" X .250"	1
15	16532	SPRING, CENTURY NN-7	1
16	03002	O-RING, 2-210, 1" OD X 1/8 SECTION	6
17	05010	SNAP RING, 1" EXTERNAL	6
18	03025	BACK-UP RING, 1" TEFLON	6
19	05573	SH CAP SCREW, 1/4-20 NC X 3/8 ZINC	3
20	16535	CONTROL BLOCK (HIGH/LOW)	1
21	05023	PIPE PLUG, 1/8"	1

RELEASE DATE	10/26/2017
REVISED DATE	03/01/2018
REVISION #	1

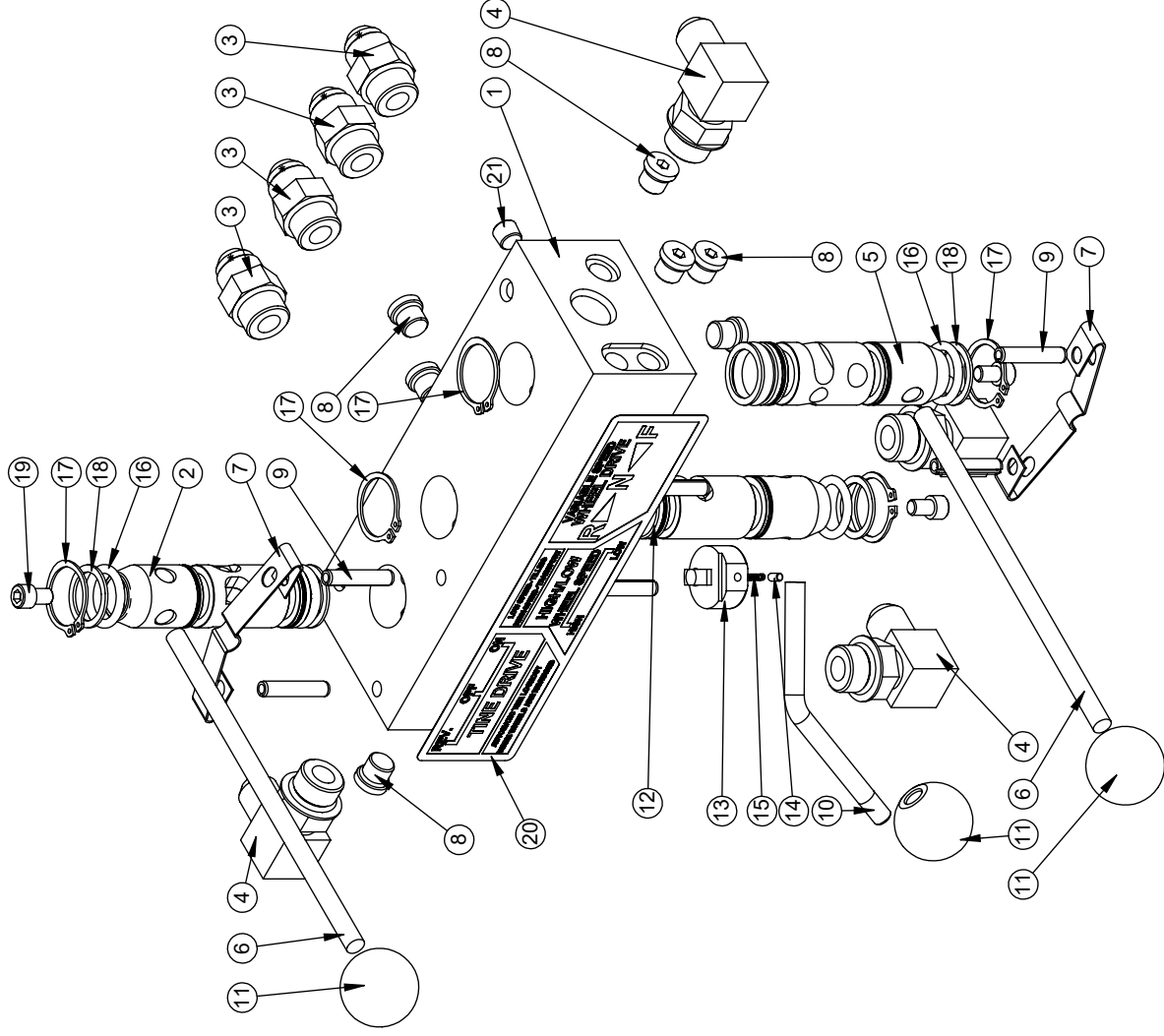

BARRETO

TITLE: CONTROL BLOCK ASSEMBLY

PRODUCT LINE:TILLER

SCALE: 1:4

SHEET 1 OF 3

DWG# 00614

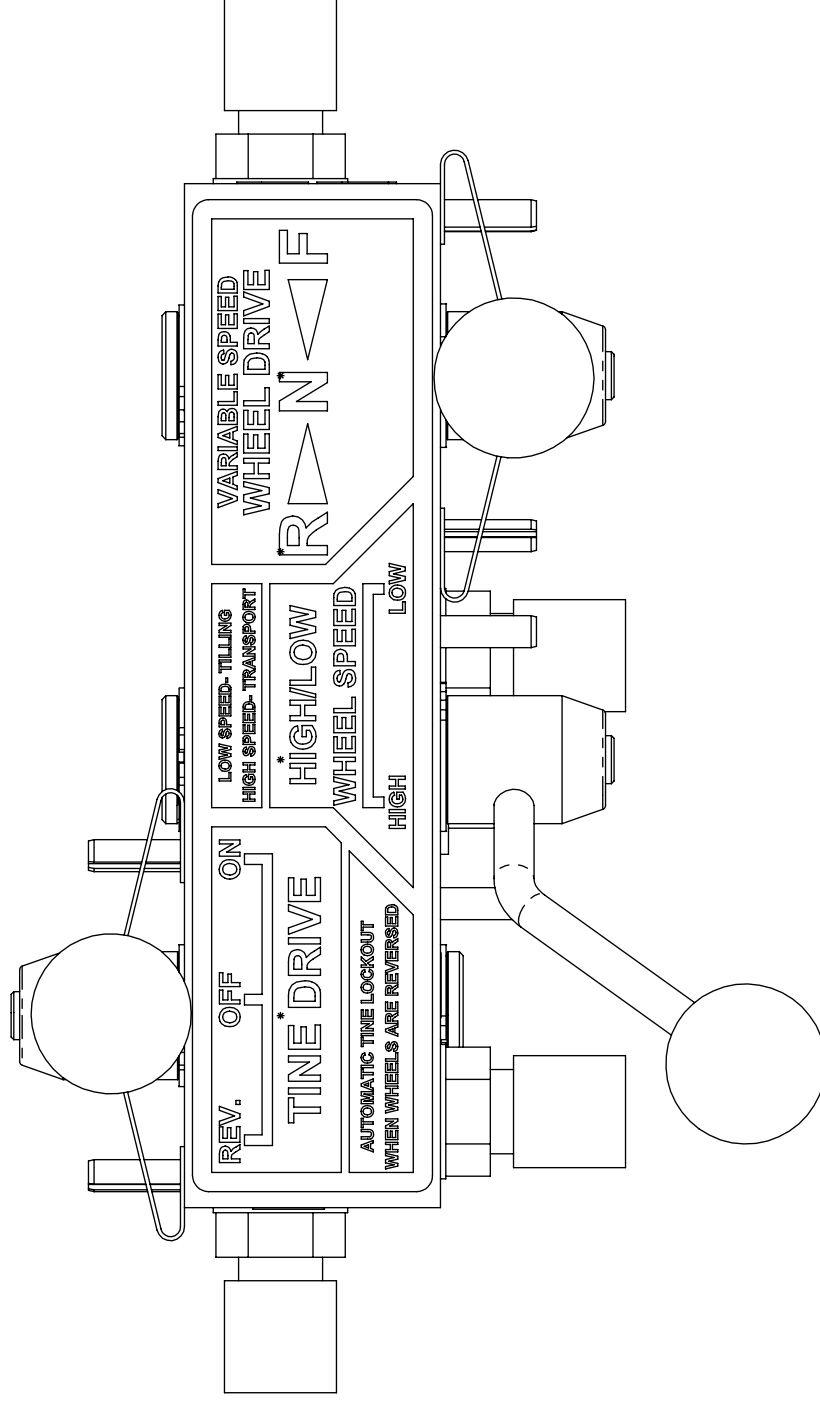

TITLE: CONTROL BLOCK ASSEMBLY

PRODUCT LINE:TILLER

SCALE: 1:4
SHEET 2 OF 3

DWG# 00614

BARRETO

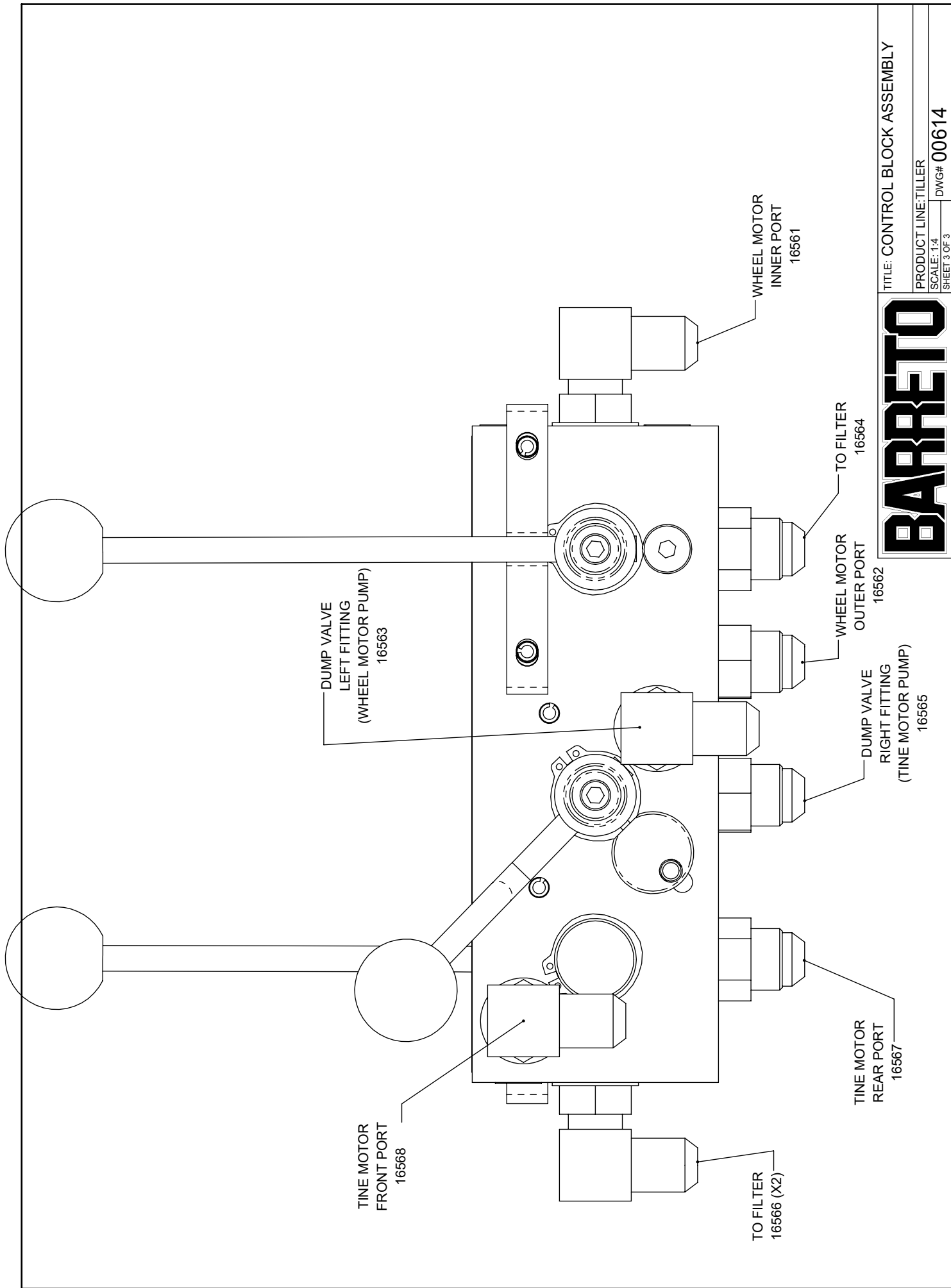

BARRETO

TITLE: CONTROL BLOCK ASSEMBLY

PRODUCT LINE: TILLER

SCALE: 1:4

SHEET: 3 OF 3

DWG# 00614

RELEASE DATE	11/28/2017
REVISED DATE	NEW
REVISION #	0

ITEM NO.	PART NUMBER	DESCRIPTION	QTY.
1	16537	918 AXLE	1
2	03280	BALL BEARING, SKF 6206	2
3	10174	AXLE BEARING HOUSING	2
4	03012	SEAL, AXLE	4
5	05033	HAIR SPRING COTTER P2	4
6	16538	AXLE SPACER	2
7	16553	CHAIN IDLER ARM	1
8	10277	BUSHING, IGUS JFI-2024-16	1
9	03202	THRUST WASHER, 1.25 X 1.75 X .030	1
10	10615	WASHER, 5/16 USS ZINC	1
11	16550	SPROCKET, #50 28 T, 1-1/8 BORE, 50BS28	1
12	16551	CHAIN- #50 53 LINK	1
13	05140	WHIZ-LOCK 5/16 - 18 X 3/4	1
14	12113	WHIZ-LOCK 1/4 - 20 X 1-1/2	6
15	05044	GREASE ZERK, 1/4-28 UNF	2
16	05606	SNAP RING, 1-1/8" EXTERNAL	4
17	10623	O-RING, 2-010, 3/8 OD X 1/16 SECTION	6
18	10602	O-RING, 2-239, 3-7/8 OD X 1/8 SECTION	2
19	10211	O-RING, 2-143, 2-5/8 OD X 3/32 SECTION	2
20	10344	HHCS, 3/8-16 NC X 3 G5 ZN FULL	1
21	10928	NUT, 3/8-16 NC GRB PLAIN	1
22	05199	KEY, 1/4 X 1/4 X 2-1/2 HARDENED	2
23	05318	KEY, 1/4 X 1/4 X 1	1
24	16552	IDLER SPROCKET	1
25	03013	FELT WASHER, 1-1/8 X 2 X 1/8	2

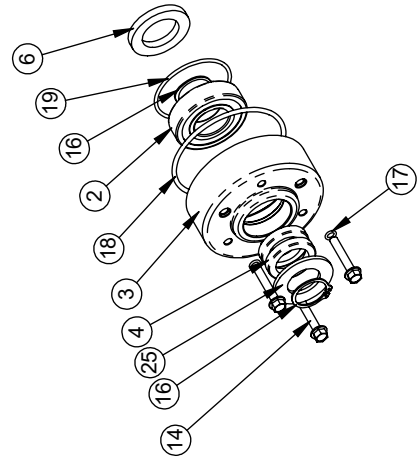
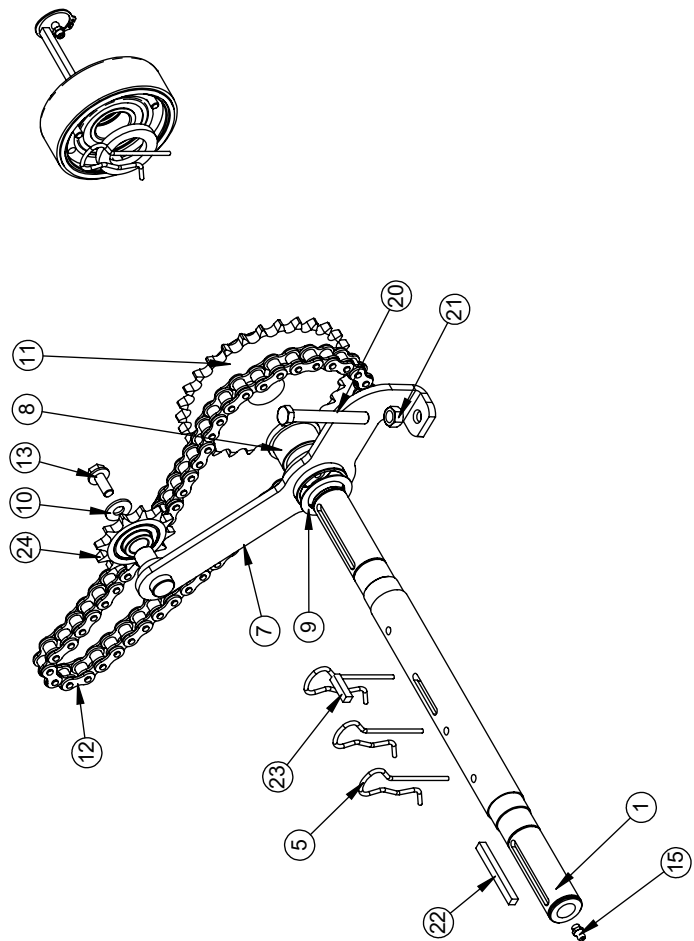
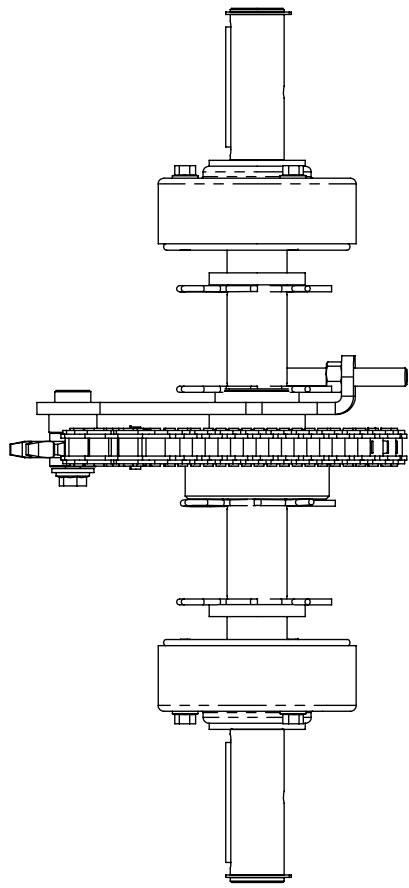

BARRETO

TITLE: AXLE ASSEMBLY

PRODUCT LINE:TILLER

SCALE: 1:6
SHEET 1 OF 1

DWG# 00617

RELEASE DATE	10/26/2017
REVISED DATE	06/30/2020
REVISION #	0

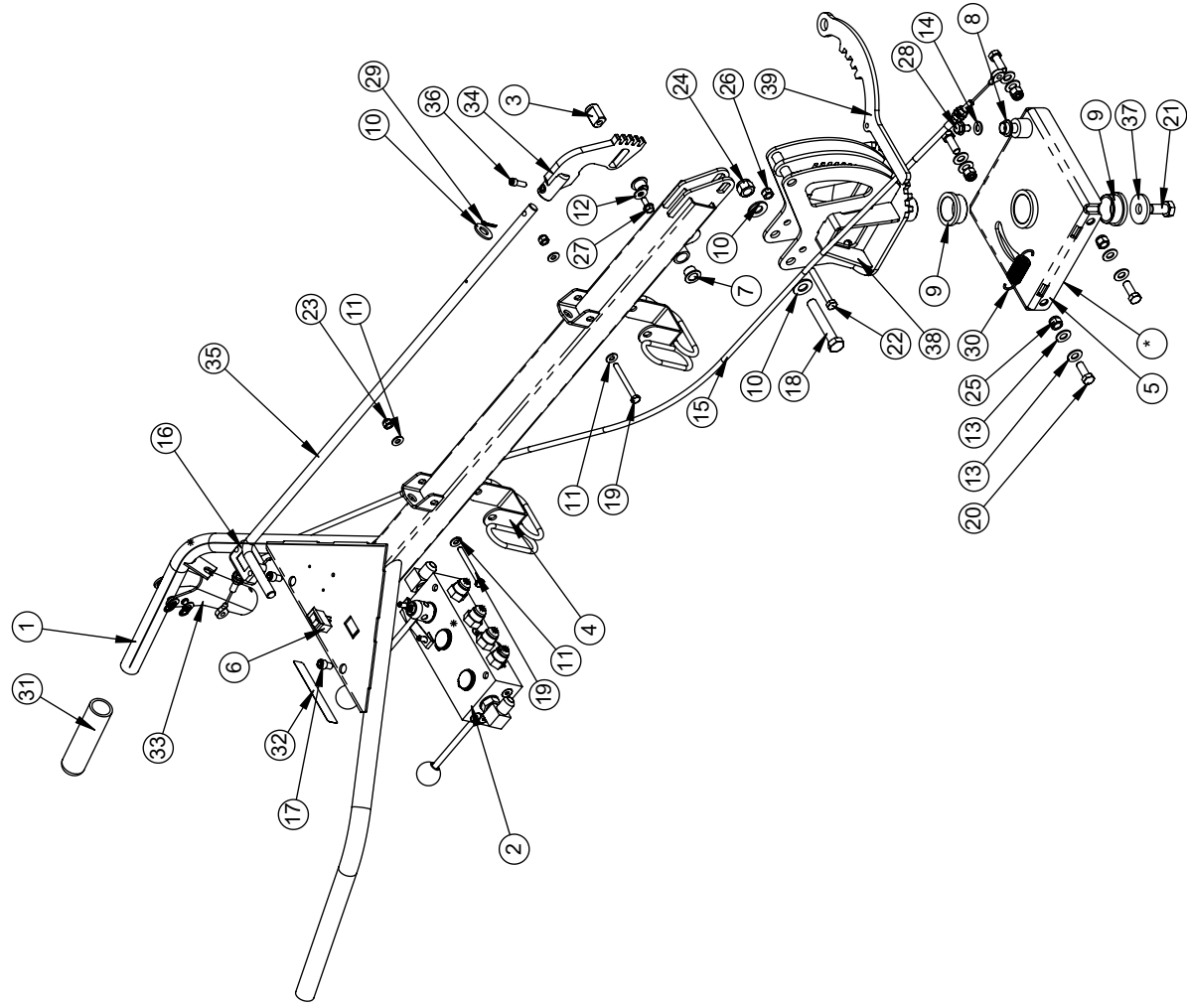

ITEM NO.	PART NUMBER	DESCRIPTION	QTY.
1	16545	HANDLE BARS R1	1
2	00614	CONTROL BLOCK ASSEMBLY	1
3	16544	SLIDE PIN	1
4	16542	HOSE KEEPER-918	2
5	16504	PIVOT MOUNT	1
6	06420	ROCKER SWITCH, IGNITION OFF/ON	1
7	03501	BUSHING, IGUS MFI-0810-08	2
8	10100	BUSHING, IGUS RFI-0810-06	1
9	10498	BUSHING, IGUS MFI-2024-12	2
10	05102	WASHER, 1/2 SAE ZINC HARDENED	3
11	05081	WASHER, 1/4 SAE ZINC	4
12	05078	WASHER, 1/4 USS ZINC	1
13	05101	WASHER, 3/8 SAE ZINC	8
14	10615	WASHER, 5/16 USS ZINC	1
15	16510	CABLE, ACTUATOR	1
16	03009-R2	HOUR METER, W/O FLASH ALERT	1
17	NEW	SH CAP SCREW, 5/16-18 NC X 1/2 ZINC	2
18	05093	HH CAP SCREW, 1/2-13 NC X 3 G5 ZINC	1
19	05123	HH CAP SCREW, 1/4-20 NC X 2-1/2 G5 ZINC	2
20	05059	HH CAP SCREW, 3/8-16 NC X 1 G5 ZINC	4
21	05067	HH CAP SCREW, 1/2-13 NC X 1 G5 ZINC	1
22	05568	HH CAP SCREW, 5/16-18 NC X 2-1/2 G5 ZINC	1
23	05096	NUT, NYLOCK, 1/4-20 NC ZINC	2
24	05098	NUT, NYLOCK, 1/2-13 NC ZINC	1
25	05073	NUT, NYLOCK, 3/8-16 NC ZINC	4
26	05273	NUT, NYLOCK, 5/16-18 NC ZINC	1
27	05069	WHIZ-LOCK 1/4 - 20 X 5/8	1
28	05169	WHIZ-LOCK 5/16 - 18 X 1/2	1
29	05222	COTTER PIN 1/8 X 3/4	1
30	16513	SPRING- CENTURY 3959	1
31	03032-01	GRIP, 1 X 5 (P/N 03032 IS A PAIR)	2
32	16536	WHEEL RANGE	1
33	03029	LEVER ASSEMBLY (COMPLETE)	1
34	16512	ADJUSTMENT COG	1
35	16511	ADJUSTMENT BAR SHAFT	1
36	05611	SH CAP SCREW, 1/4-20 NC X 3/4 ZINC	1
37	11027	SHAFT WASHER	1
38	16503 R1	HANDLEBAR PIVOT R1	1
39	16505 R1	LOCK HANDLE- R1	1

BARRETO

TITLE: HANDLEBAR ASSEMBLY

PRODUCT LINE:TILLER

SCALE:1:24

SHEET:1 OF 2

DWG# 00615

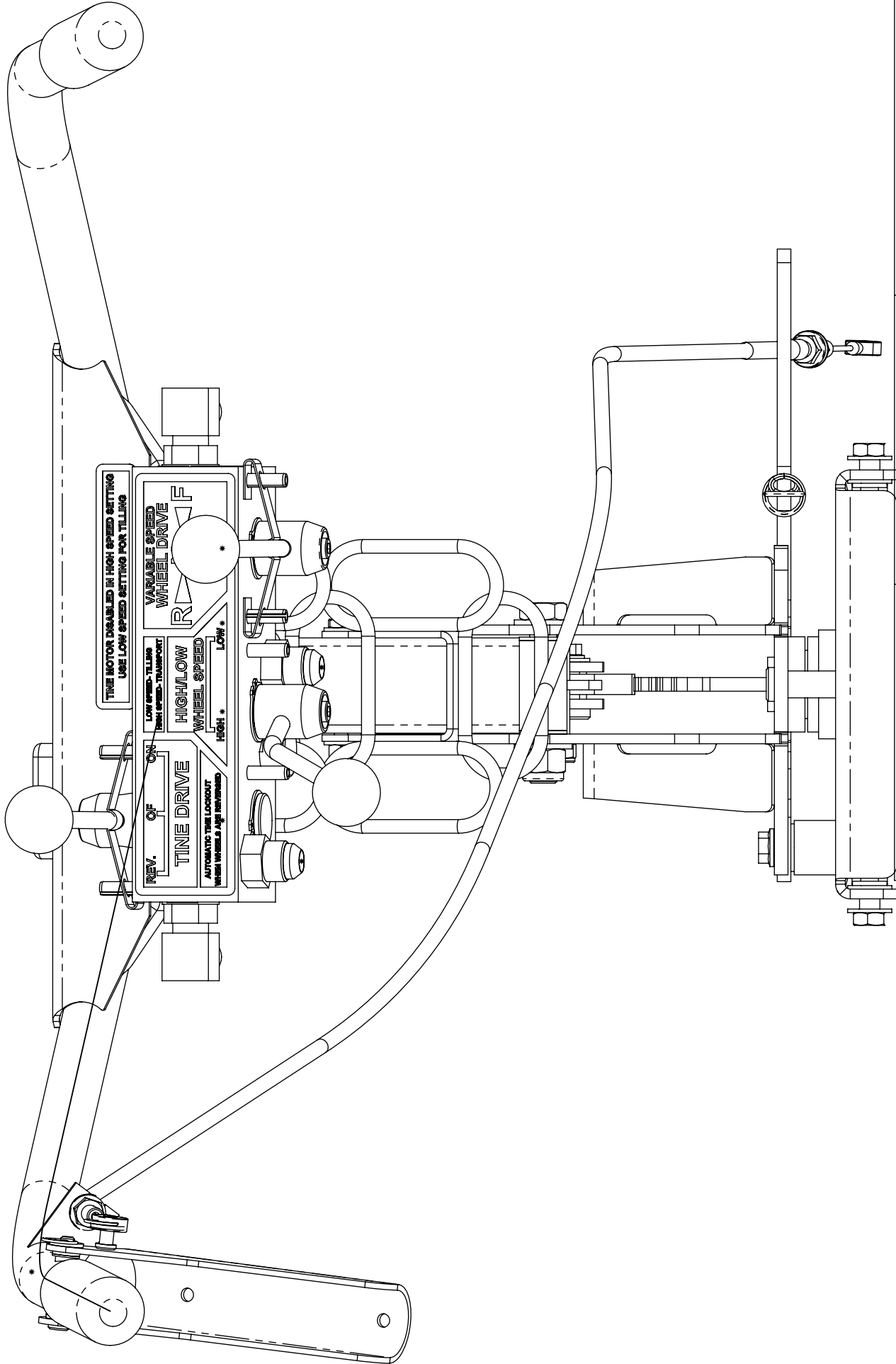

BARRETO

TOLERANCES UNLESS OTHERWISE SPECIFIED

FRACTIONS:
 >= 1/16 = ±1/16
 1/32 = ±1/32
 1/64 = ±1/64

DECIMALS:
 X = ±.1
 XX = ±.03
 XXX = ±.005

ANGLES:
 ±2°

TITLE: HANDLEBAR ASSEMBLY
 PRODUCT LINE: TILLER
 SCALE: 1:3
 SHEET 2 OF 2
 DWG# 00615

RELEASE DATE	10/27/2017
REVISED DATE	NEW
REVISION #	0

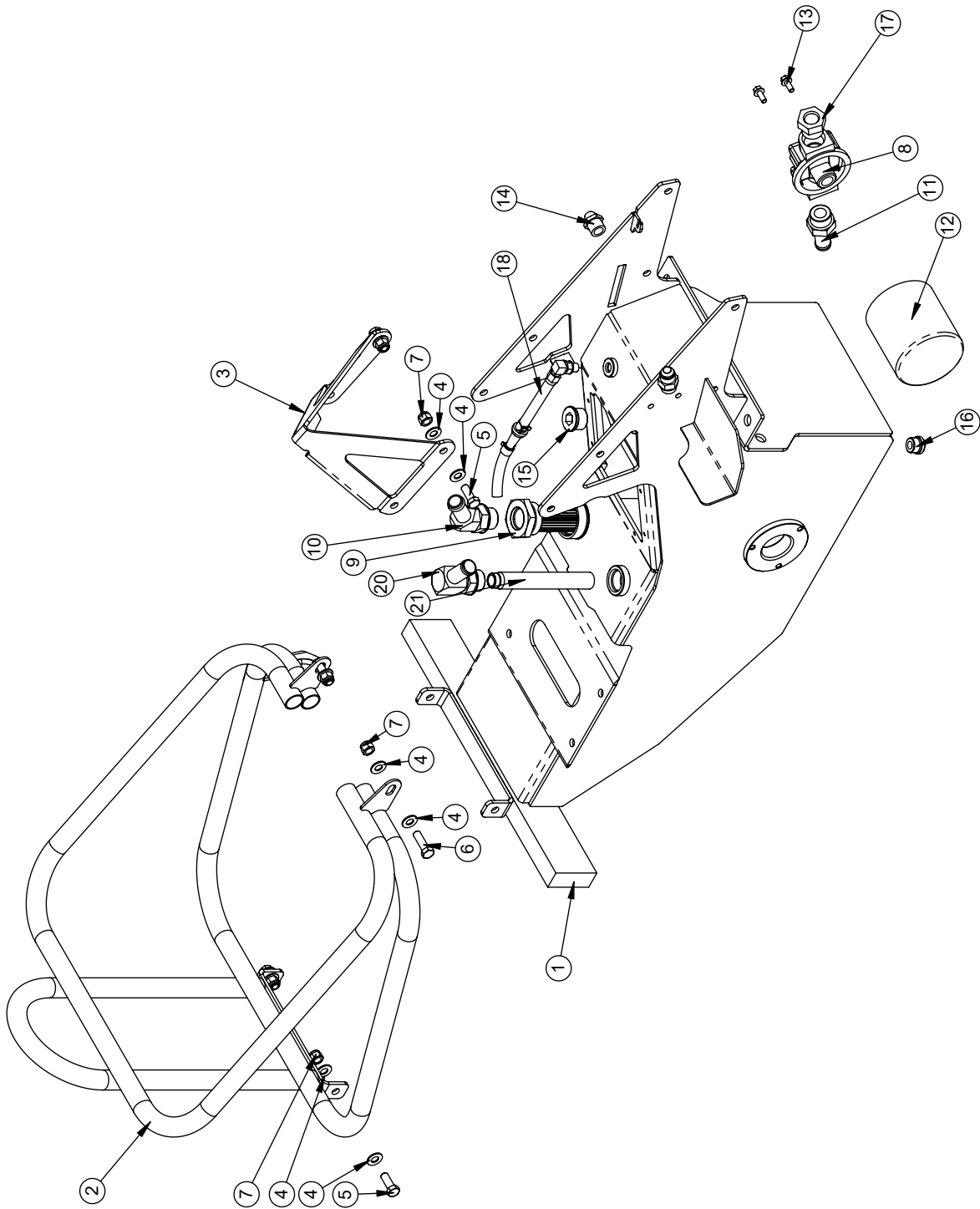

TITLE: BODY ASSEMBLY

BARRETO

PRODUCT LINE:
SCALE: 1:16
SHEET 1 OF 2
DWG# 00616

ITEM NO.	PART NUMBER	DESCRIPTION	QTY.
1	16501	TILLER BODY	1
2	16524	ENGINE GUARD, 918 R1	1
3	16539	LIFT HOOK	1
4	05101	WASHER, 3/8 SAE ZINC	12
5	05059	HH CAP SCREW, 3/8-16 NC X 1 G5 ZINC	4
6	05171	HH CAP SCREW, 3/8-16 NC X 1-1/4 G8 ZINC	2
7	05073	NUT, NYLOCK, 3/8-16 NC ZINC	6
8	04403	FILTER HEAD, #12 O-RING	1
9	10247	SUMP SCREEN #20 EXT #12 INT O-RING	1
10	10362	FITTING, 4603-12-12	1
11	04219	FITTING, 4604-12-12	1
12	03951	FILTER, HYDRAULIC OIL, WITH BY-PASS	1
13	05069	WHIZ-LOCK 1/4 - 20 X 5/8	2
14	03503	SIGHT GAUGE	1
15	10526	FITTING, 6409-12 PLUG	1
16	10361	FITTING, 6409-8 PLUG	1
17	04222	FITTING, 6410-12-8	1
18	10189 R2	BREATHER HOSE ASSEMBLY	1
19	04520	FITTING, 6400-8-8	1
20	04202	FITTING, 4601-12-12	1
21	10481	RETURN TUBE, #8 O-RING	1

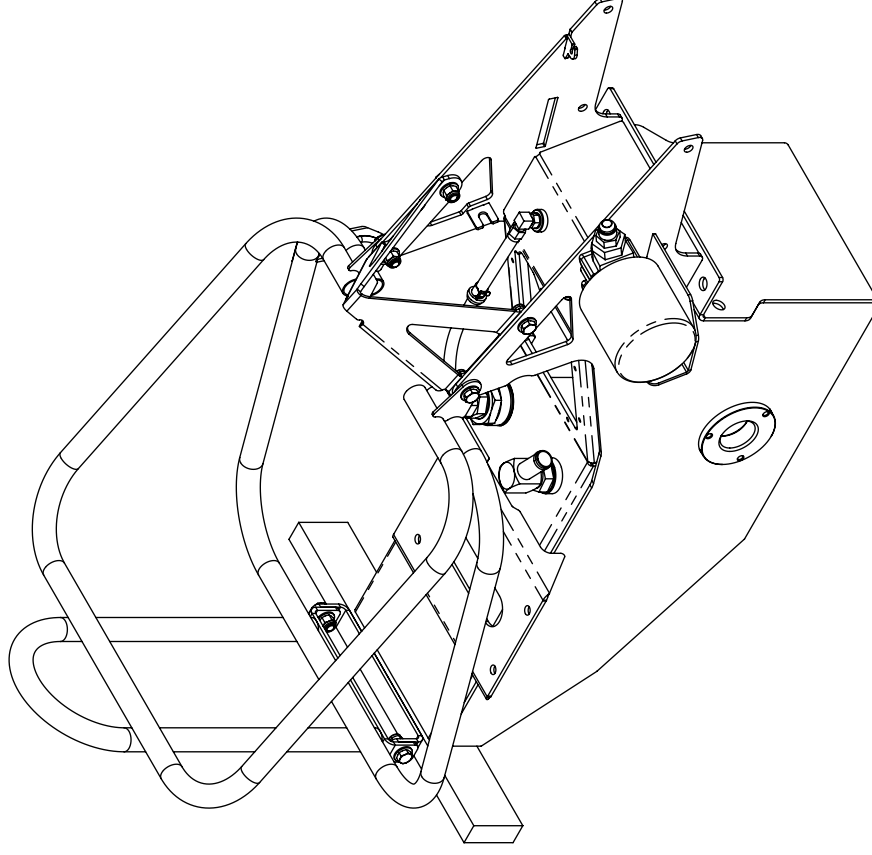

BARRETO

TITLE: BODY ASSEMBLY

PRODUCT LINE:

SCALE: 1:16

SHEET 2 OF 2

DWG# 00616

REF. QTY.	PART NO.	DESCRIPTION
1	02269	WHEEL HUB
2	01252	FREE WHEEL HUB
3	03168	BUSHING, SLEEVE, NYLON, IGUS MSI-2832-12
4	05610	SNAP RING, SH-175, 1-3/4" EXTERNAL
5	05066	KNURLED STUD, 1/2-20 UNF X 1, G8
6	05166	KNURLED STUD, 1/2-20 UNF X 3, G8

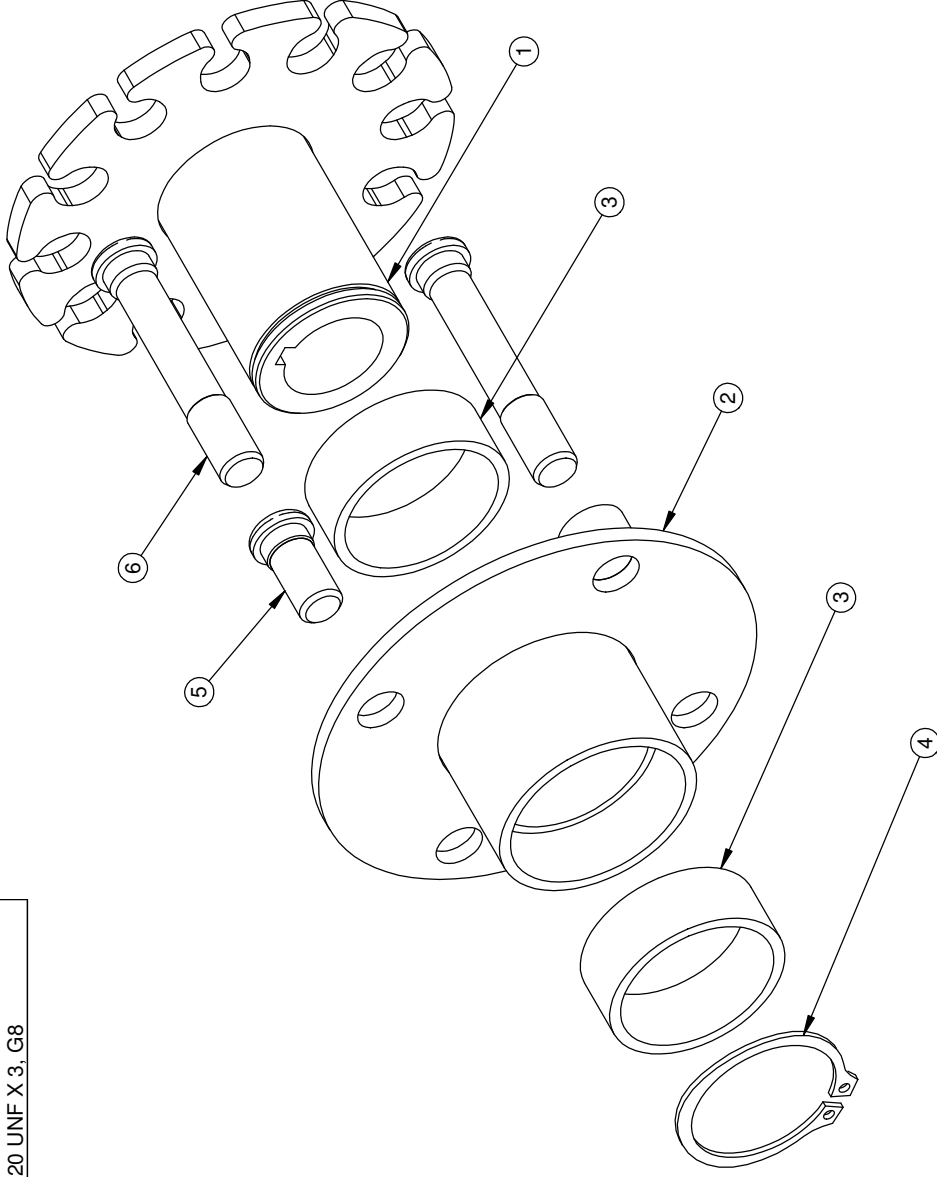

NOTES:

- 1. USAGE: 2 PER 00231 R3, 00256 R1, & 10388.
- 1 OF 00231 R3 PER 1318.
- 1 OF 00256 R1 PER 912, 916 & 918.
- 1 OF 10388 PER 1320 & 1620.

BARRETO

TITLE: WHEEL HUB ASSY, 1-1/8" BORE

PRODUCT LINE: COMMON DATE: 8/6/07

SCALE: 1:2 DWG# 02269-HUB

SHEET 1 OF 1

REF QTY.	PART NO.	DESCRIPTION
1	10142	OUTBOARD BEARING HOUSING, 4 BOLT
2	01039	SHIELD, ROLLER BEARING
3	03043	BALL BEARING, 6205
4	05024	SNAP RING, HO-200, 2" INTERNAL
5	03904	O-RING, 2-035, 2-3/8 OD X 1/16 SECTION
6	05059	HH CAP SCREW, 3/8-16 NC X 1 G5 ZINC

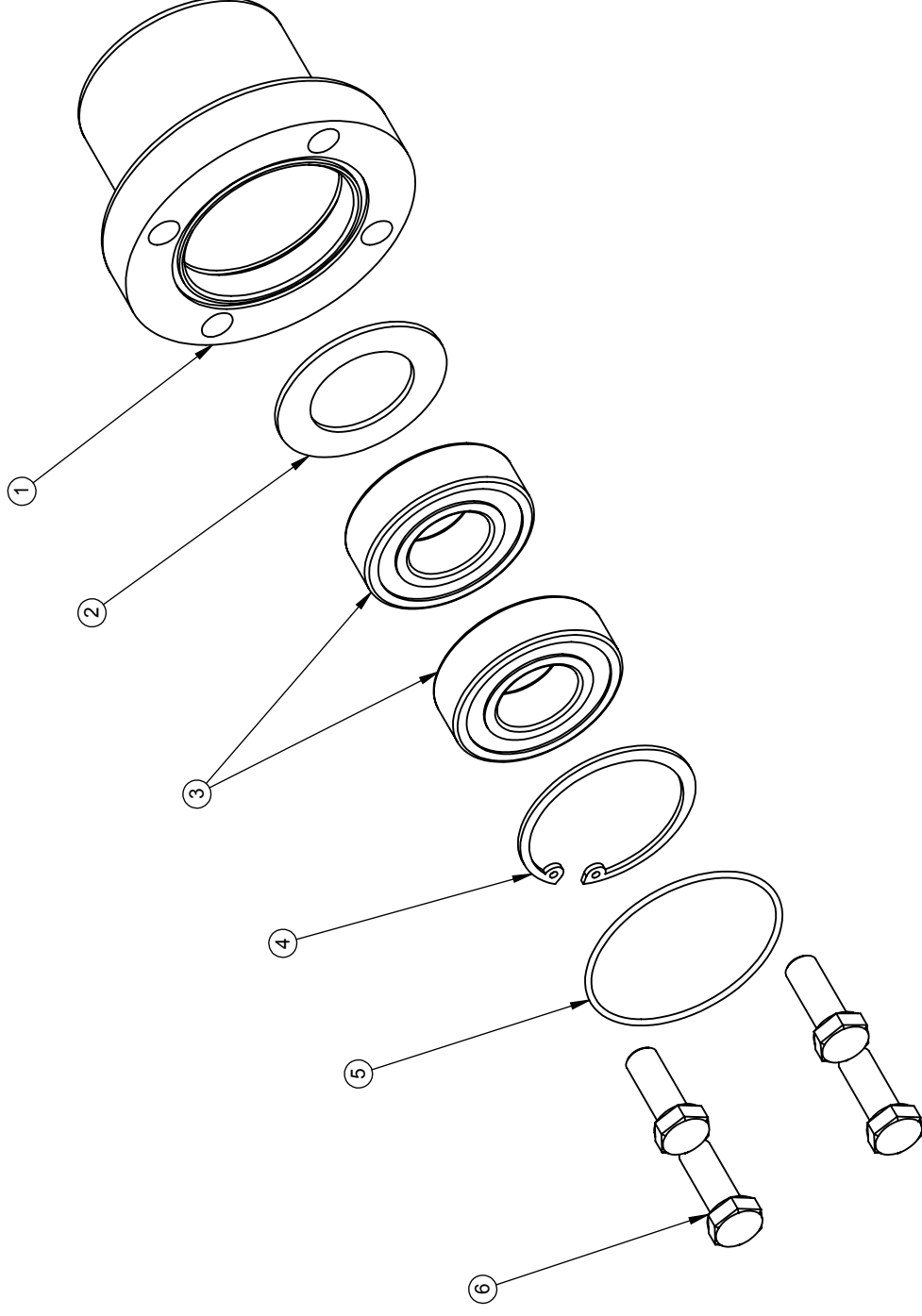

REF. QTY.	PART NO.	DESCRIPTION
1	04555	FITTING, 6801-4-4
2	04214	FITTING, JS-4-4, HOSE BARB 1/4 X 1/4 SWIVEL
3	11348	HOSE, 1/4 INCH GASOLINE, 4L5, 3-1/2" LONG
4	03062-06	CLAMP, 1/4" FUEL LINE
5	04516	BREATHER, FILTER SNAPPER 1435
6	11347	HOSE, 1/4 INCH GASOLINE, 4L5, 3-1/4" LONG

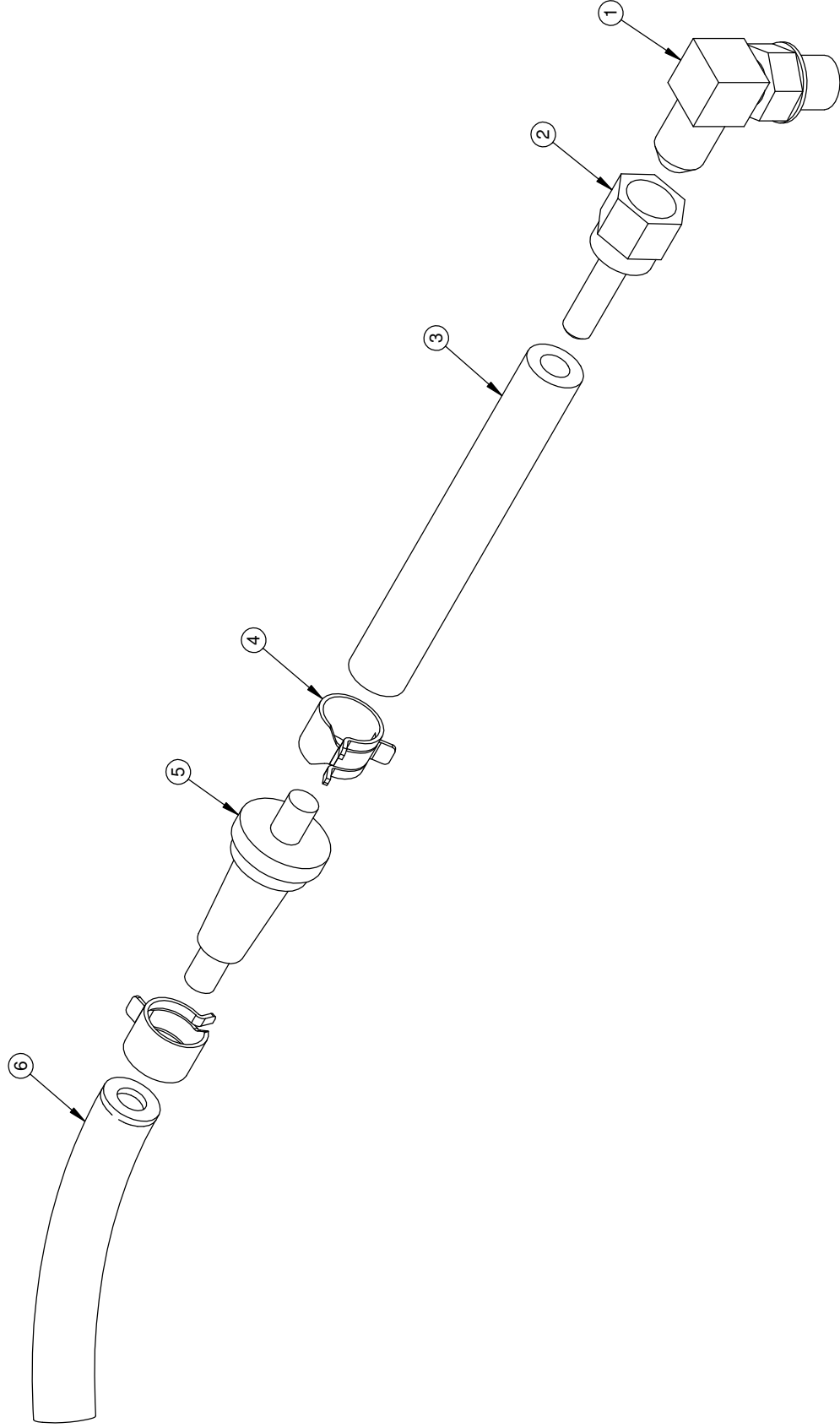

TITLE: BREATHER HOSE ASSEMBLY

PRODUCT LINE: 916 DATE: 4/26/07

SCALE: 1:1.3

DWG# 10189 R2
SHEET 1 OF 1

BARRETO

RELEASE DATE	12/01/2017
REVISED DATE	NEW
REVISION #	0

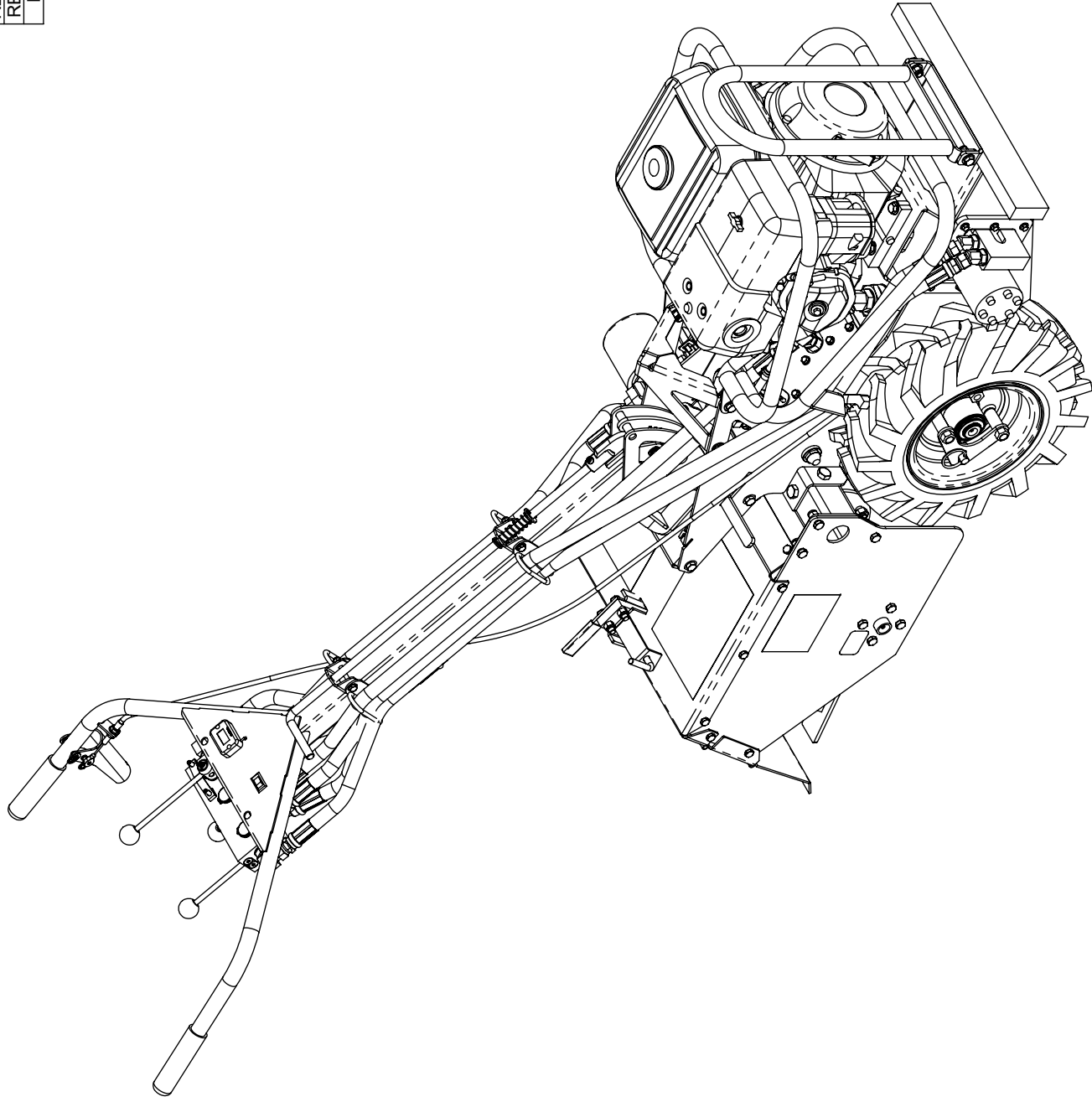

TITLE: 918 TILLER 2018

PRODUCT LINE:TILLER

SCALE: 1:32

SHEET 1 OF 2

DWG# E918 R1

BARRETO

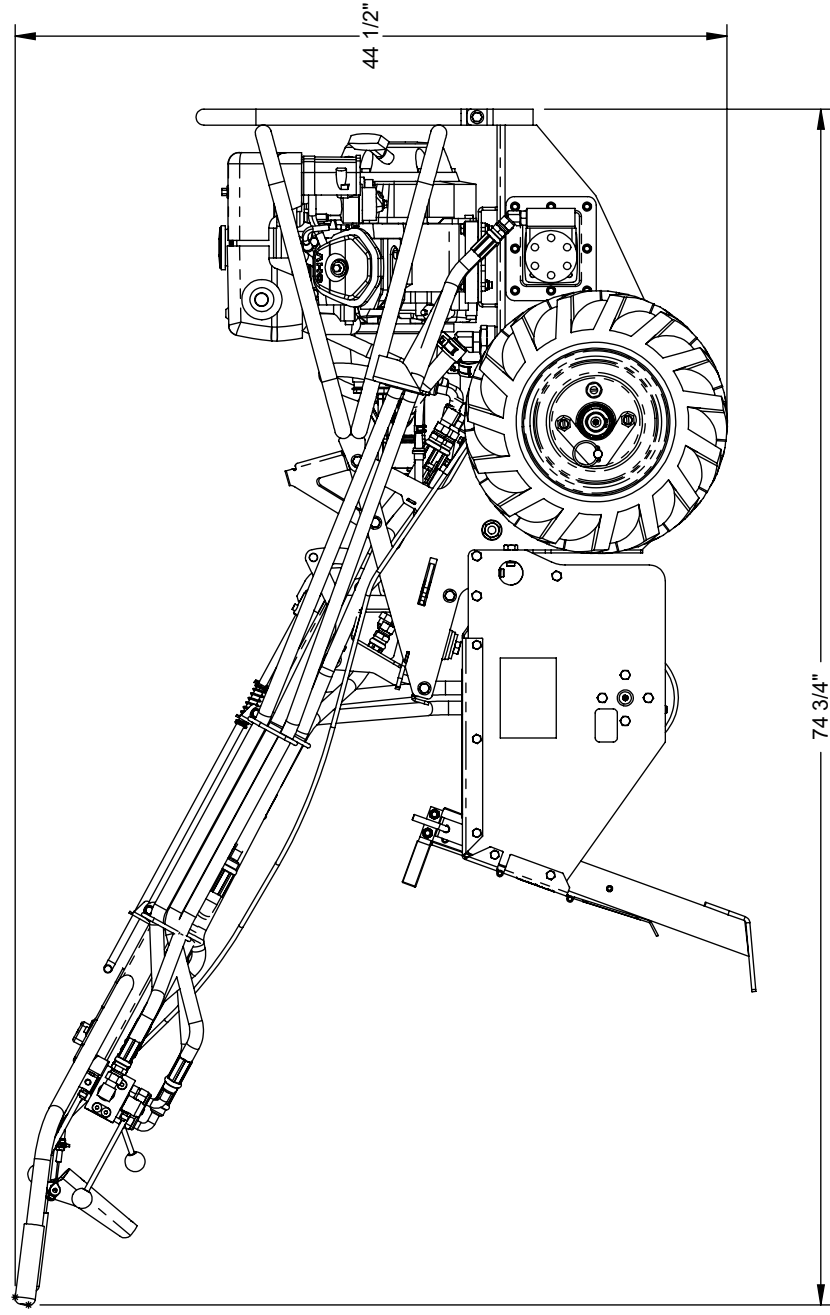
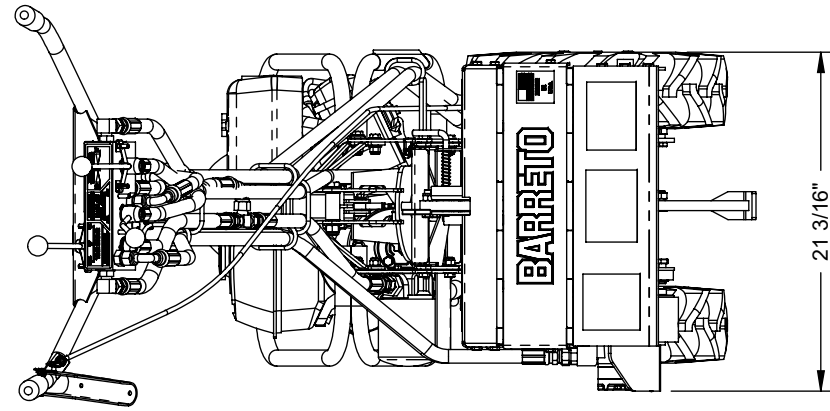

TITLE: 918 TILLER 2018

PRODUCT LINE:TILLER

SCALE: 1:32

SHEET: 2 OF 2

DWG# E918 R1

BARRETO

918/916 Tiller Decals

P/N 03040-01



P/N 03040-02



P/N 03040-03



P/N 03040-04



P/N 03040-06



P/N 03040-07

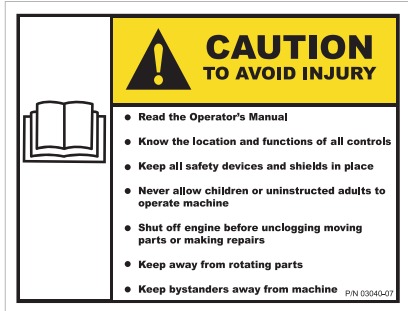

P/N 03040-08



P/N 03040-51



P/N 04340



P/N 03040-11



P/N 03040-57



P/N 03341-07



P/N 03341-22

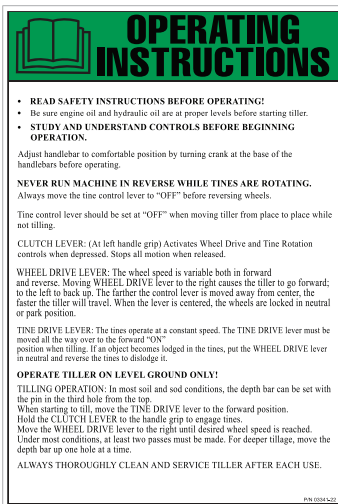

P/N 03341-23

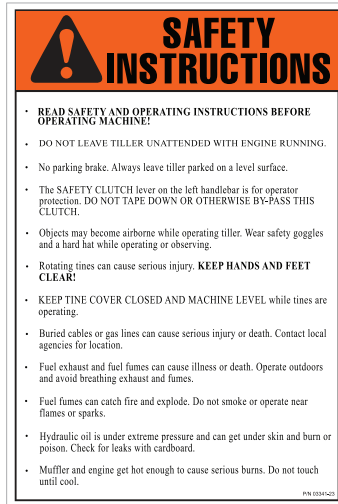

P/N 16535



P/N 16536



All decals available as a kit, p/n K3040-918Y