

THE
BARRETO
MODEL 920LS-922LS SERIES
HYDRAULIC LOG SPLITTER
OWNER/OPERATOR MANUAL

CONGRATULATIONS!

You are now the proud owner of a BARRETO log splitter. Please take a moment of your time to look over the following information. Familiarize yourself with the log splitter, its characteristics, and method of operation. Pay particular attention to the safety and operating instructions.

If you have any questions or need any replacement parts in the future, please contact us at your convenience. Our toll-free phone number, fax and email are listed below and parts may be ordered through any of these methods.

THANK YOU for your patronage and confidence in BARRETO equipment.

Barreto Manufacturing, Inc.
Innovative Equipment Engineered to Last
66498 Hwy 203, La Grande, OR 97850
(800) 525-7348 (541) 963-7348
FAX (541) 963-6755
E-Mail: info@barretomfg.com
Web Site: <http://www.barretomfg.com>

Machine Identification Record

Barreto Customer number _____
Machine model number _____
Machine serial number _____
Engine manufacturer _____
Engine model number _____
Engine serial number _____

TABLE OF CONTENTS

LOG SPLITTER ASSEMBLY INSTRUCTIONS _____	2
BREAK IN PROCEDURE _____	3
SERVICE INFORMATION _____	3
WIRING OPTIONAL LIGHTS _____	4
SAFETY INSTRUCTIONS _____	5
SAFETY INSTRUCTIONS OVERVIEW _____	6
TOWING INSTRUCTIONS _____	7
OPERATING INSTRUCTIONS _____	8
BARRETO MANUFACTURING WARRANTY _____	9
HONDA GX270 SCHEMATIC _____	10
SUBARU EX27 SCHEMATIC _____	11
SPECIFICATIONS _____	12

ASSEMBLY INSTRUCTIONS

1. Remove the log splitter from the shipping crate. Please inspect it immediately for any damage and notify the shipping company and Barreto Manufacturing, Inc. right away if any is found.
2. Fasten the tongue to the frame using four 1/2" x 1" bolts supplied.
3. Check the reservoir according to instructions in "Service Information" following.
4. Fill the engine with fuel and oil according to the engine manual.

BREAK IN PROCEDURE

KEEP ALL PERSONNEL CLEAR OF MACHINE DURING BREAK IN TO PREVENT INJURY!!

Before using the log splitter, let the engine run for 30 minutes at half throttle. Work the hydraulic cylinder out and in without splitting any wood.

SERVICE INFORMATION

1. Check reservoir level using sight glass on the left side of the tank. If required, add to reservoir tractor transmission / hydraulic fluid. For machine use in ambient temperatures between +32°F (0°C) and +90°F (32°C) hydraulic fluid ISO 68 is recommended. If the machine is operated at temperatures below +32°F (0°C) then hydraulic fluid ISO 46 is recommended. Recheck the oil level after the log splitter has been run and oil has been circulated through the hydraulic system. Routinely check the level thereafter. **DO NOT OVERFILL THE TANK.**
2. Change the hydraulic oil filter after the first 50 hours of use. Change it after every 200 hours thereafter.
3. Add 1 quart of hydraulic oil to the reservoir with each oil filter change.
4. Check all hydraulic fittings for leaks and tighten if necessary.
5. The grease zerk on both swing arm pivot pins should be greased once a week or so, depending upon use.

IMPORTANT: The engine is normally serviced prior to shipping. However, shipping regulations may prohibit this. Check the levels and add oil and fuel as required before starting. Service according to the engine manual before starting.

WARNING: Running the log splitter without hydraulic oil will cause serious damage to the hydraulic pump. **CHECK RESERVOIR LEVEL BEFORE STARTING THE MACHINE.**

WIRING THE OPTIONAL LIGHTS

All parts required are provided (except the “truck plug”) in the optional lighting kit for connecting to the towing vehicle.

Route the longest wire cable (4 stranded wires in a sheath) through the shielded cable run on the right side of the frame, then through the tongue. The far left diagram is for tongues made prior to the wiring hole in the bottom of the tube (middle diagram). Secure with the cable clamp at the front of the tongue tube as shown in right diagram.

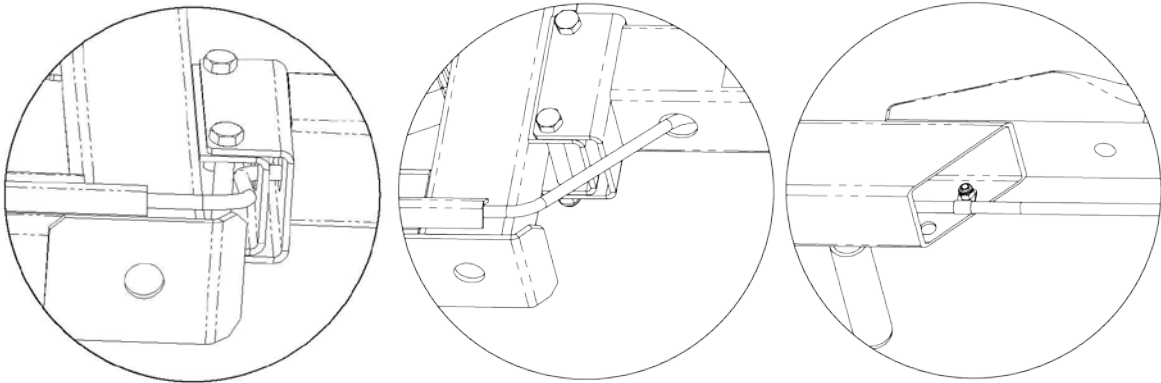

Route the shorter wire cables through the shielded cable runs on the bottom of the frame (under the hydraulic fluid tank). The 36” cable goes to the right hand light, and the 41” cable to the left hand light.

Using quick splices connect the stranded wires between the cable and each tail light. Match the brown wires for the tail lamps. Green wires are for ground. The red wire for the RH turn signal connects to the red wire in the cable. The red wire for the LH turn signal connects to the yellow wire in the cable.

There are holes in the frame and light mounting brackets for anchoring wires with tie wraps.

Four pin connectors are typical for the three lighting functions (tail, turn, and brake) plus one pin for the ground wire. Vehicle manufacturers have not standardized wiring colors. We recommend that a circuit tester be used on the tow vehicle wiring to locate the correct wire for each function. The wire that supplies 12 volt DC when switched on with the head lights of the tow vehicle is for the tail lights.

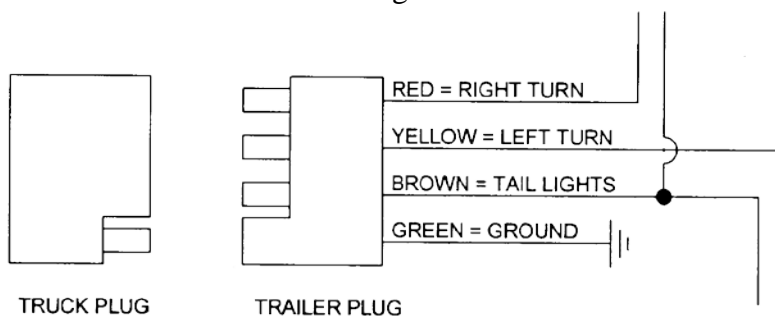

SAFETY INSTRUCTIONS

1. CAREFULLY READ THE OPERATORS MANUAL. FAILURE TO READ AND UNDERSTAND THE MANUAL CAN RESULT IN VERY SERIOUS INJURY.
2. Do not change or alter the machine in any way. All shields, guards, safety devices and decals must be kept in place.
3. ALWAYS WEAR SAFETY GLASSES, gloves and steel-toed boots when operating the log splitter.
4. Keep clothing, hands, feet and other body parts away from moving parts.
5. Operate outdoors and avoid breathing exhaust and fumes. Fuel exhaust and fuel fumes can cause illness or death.
6. Fuel-fumes can catch fire or explode. Do not smoke or operate near flames or sparks.
7. Make sure the latch is locked when using in either vertical or horizontal position.
8. Shut off the engine when the log splitter is left unattended, regardless of the length of time.
9. Always load and position the log with your hands on the side of the log. Never position with your hands on the ends of the log.
10. Always split wood in the direction of the grain, never across the grain.
11. NEVER ALLOW THE LOG-SPLITTER TO BE OPERATED BY MORE THAN ONE PERSON. ONLY THE PERSON LOADING THE LOG IN THE SPLITTER SHOULD OPERATE THE CONTROL VALVE.
12. No person should remove split wood while the splitter is in operation.
13. The operator should only operate the control lever with their hands, NEVER with elbows, feet or other body parts.
14. Never operate the log splitter while under the influence of any alcohol, drugs or medication.
15. The log-splitter should be used only on dry level ground. Never use on a slope or where there is not sure footing.
16. Keep clear of falling wood.
17. Children should be kept away from the log-splitter at all times.

SAFETY INSTRUCTIONS (continued)

18. Always shut off the engine and remove the spark plug wire when performing any maintenance on this equipment.
19. Never climb on or step over the log splitter.
20. Keep the work area free from split wood or anything that one might trip over.
21. Always stay in the operator's position (near controls) when splitting wood.
22. Never refill the fuel tank with the engine running. Always allow time for the engine to cool down before refueling.
23. The muffler and engine get hot enough to cause serious burns. Do not touch until cool.
24. Hydraulic oil is under extreme pressure and can get under skin and burn or poison. Check for leaks with cardboard.

SAFETY INSTRUCTIONS OVERVIEW

READ SAFETY AND OPERATING INSTRUCTIONS BEFORE OPERATING!

USE COMMON SENSE AND PLENTY OF IT!

Wear adequate hearing protection while operating or observing.



WARNING: Exposure to loud noise is cumulative and may permanently damage your hearing.

Wear safety boots and gloves. Wear close-fitting clothing. Contain long hair. Do not wear jewelry. Wear reflective clothing if working near traffic.

Only operate outdoors and avoid breathing engine exhaust and fumes.



WARNING: Engine exhaust contains carbon monoxide gas that is toxic. Breathing it can cause unconsciousness and death.

Adequate lighting is required, daylight or artificial, for safe operation of the log splitter.

Allow adequate side and overhead clearances between log splitter and buildings, fences, and trees.

Always leave the log splitter parked on a level surface.



WARNING: Do not park on an incline. Move the log splitter to a level surface. Do not leave the log splitter unattended with the engine running.



SAFETY INSTRUCTIONS OVERVIEW (continued)

Do not operate the log splitter near any source of flammable dust or vapors.



WARNING: Sparks from the engine exhaust can cause an explosion or fire in a flammable or explosive atmosphere. Fuel fumes can catch fire or explode.

Do not operate the log splitter near flames or sparks.



WARNING: Fuel fumes can catch fire or explode.

Shut off the engine and allow it to cool before refueling.



WARNING: Fuel fumes can catch fire or explode. Do not smoke when refueling. Do not refuel near a source of flames or sparks.

Do not touch the engine, muffler, or any of the hydraulic components until cool.



WARNING: The muffler and engine get hot enough to cause serious burns. For the safety of yourself and others, allow enough time for the engine, muffler, and the hydraulic fluid to cool completely before performing any cleaning or maintenance.

Avoid contact with hydraulic fluid.



WARNING: When the machine is operating, hydraulic fluid is under extreme pressure and can get under skin and burn or poison.

Never lift the log splitter over any person at any time.



WARNING: If the log splitter should fall it would crush anybody under it.

We recommend having a fire extinguisher suitable for petrol fires in the operating area.

Attachments can change the center of mass and machine operations. Use only Barreto attachments.

TOWING INSTRUCTIONS

Be sure to obey all traffic laws and rules of the road while towing the Barreto log splitter. Never exceed 45 miles per hour while towing. The towing vehicle should be in legal operating condition. Refer to the following checklist before towing:

- The towing vehicle should have a 2" ball. Be sure it is in good repair and securely fastened to the vehicle.
- Securely fasten the hitch to the ball by tightening the hitch nut.
- Thread the safety chain through the loop in the hitch nut handle to prevent it from vibrating loose while towing. Attach the safety chain to the towing vehicle in such a way that it cannot come off accidentally.
- Swivel jack or stand should be parallel with tongue with pin in place.
- Be sure rail is locked in horizontal position when towing.
- Check the hitch-to-ball connection after driving a few blocks and re-tighten if necessary.
- Always exercise extreme caution and allow extra clearance while towing.
- If local law requires trailer lights, be sure they are in good repair and are in proper working condition. Lights should be connected according to local and state laws.

DRIVE SAFELY!

OPERATING INSTRUCTIONS

1. READ SAFETY INSTRUCTIONS BEFORE OPERATING!
2. Position the log splitter on dry level ground. Never use it on a slope or where there is not sure footing. When you disconnect the log splitter from the tow vehicle, pull the detent ring pin from the front leg or optional swivel jack. Rotate the leg or jack to the vertical position and replace the pin.
3. Be sure engine oil and hydraulic oil are at proper levels before starting the engine.
4. Fill the fuel tank before you start while the engine is cold.
5. Turn the fuel line valve, choke, and engine switch to “on” position, then pull the starter rope. Turn off the choke when appropriate. Refer to engine owner’s manual for details.
6. Always load and position the log with hands on sides of the log. Never position with your hands on the ends of the log. Always split wood in the direction of the grain, never across the grain. Your log splitter may have optional log holders. If so, the log holders will cradle the wood to hold it on the rail, allowing hands free operation when splitting. The log holders have two positions. The upper position provides the most support, designed to use when the rail is horizontal. The low position is recommended when the rail is vertical.
7. Your log splitter may have the optional safety lockout feature. If so, push down on either lockout lever with one hand, then move the valve control lever with your other hand toward the log to split wood. After splitting, move the lever away from the log. The valve detent will hold it in a retracting operation, and will automatically release when the cylinder rod is fully retracted.
8. To use with the rail in the vertical position, disconnect from the towing vehicle. Pull the horizontal position latch pin and rotate the rail using the handle provided. Make sure the vertical latch pin locks the rail into place. Both latch pins are spring-loaded but can be held unlocked by rotating the pin handle behind the stop. When you switch from horizontal to vertical, the end of the rail hits the ground before the rail latches. Typically the whole machine rolls back a few inches as the rail approaches vertical and the latch catches. If the machine is attached to the towing vehicle it becomes very difficult if not impossible to latch the rail to vertical.

BARRETO MANUFACTURING, INC. EQUIPMENT WARRANTY

Barreto Manufacturing, Inc. warrants all BARRETO equipment to be free of defects in material and workmanship for a period of one (1) year, dating from delivery to the original user.

This Warranty is in lieu of all other warranties, whether written or implied, and is limited to:

1. Replacement of parts returned to the dealer and/or factory and determined defective upon inspection. (Replacement for parts to dealers shall be at dealer cost plus shipping charges.)
2. Time for pick-up and/or delivery, transportation or service calls by dealers is excluded. Manufacturer reserves the right to determine reasonable time required for repair.

Warranty does not apply to damage caused by abuse or neglect. Time and materials required for normal maintenance and service are also excluded from warranty coverage.

Engines, engine accessories and tires are warranted by the original manufacturers and are not covered by the Barreto Equipment Warranty. Wear parts such as tiller tines, sprockets, trencher teeth, bearings, etc. are also excluded unless it can be determined that a defect has contributed to premature wear.

TECHNICAL & CONSUMER INFORMATION

Wiring Diagrams

Oil Alert® and Electric Starter Types

ENGINE SWITCH

	IG	E	ST	BAT
OFF	○	○		
ON				
START			○	○

Bl	BLACK	Gr	GRAY
Y	YELLOW	R	RED
W	WHITE	G	GREEN

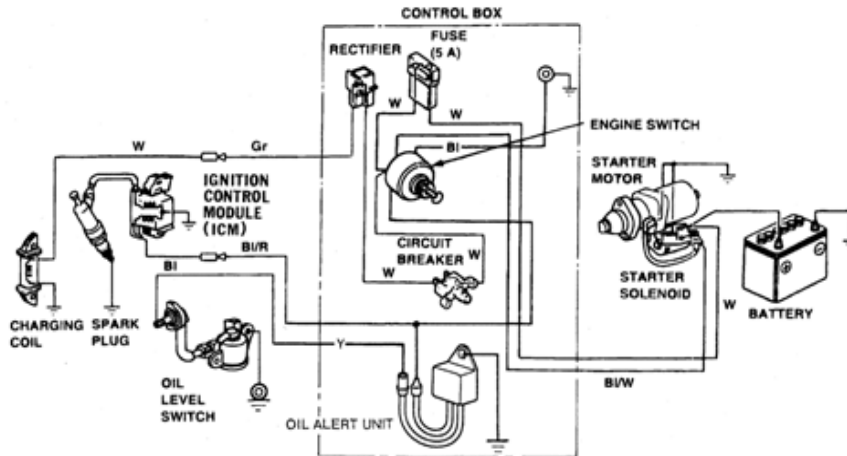

Engine Types With Oil Alert® and Without Electric Starter

Bl	BLACK
Y	YELLOW
G	GREEN

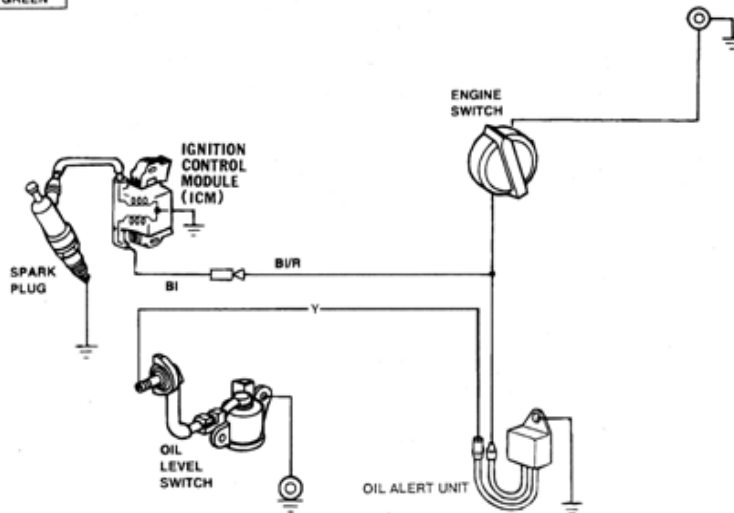

ELECTRICAL SCHEMATIC - SUBARU EX27

8. WIRING DIAGRAM

8-1 MODEL WITHOUT ELECTRIC STARTER (Models EX13, 17, 21 and 27)

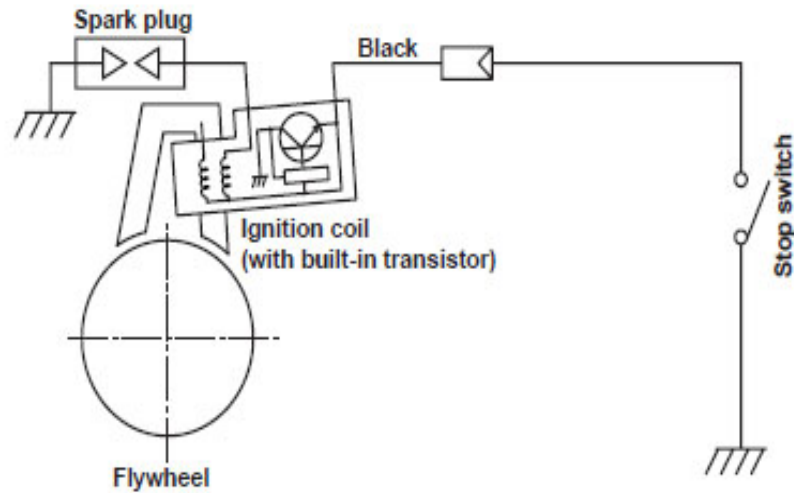
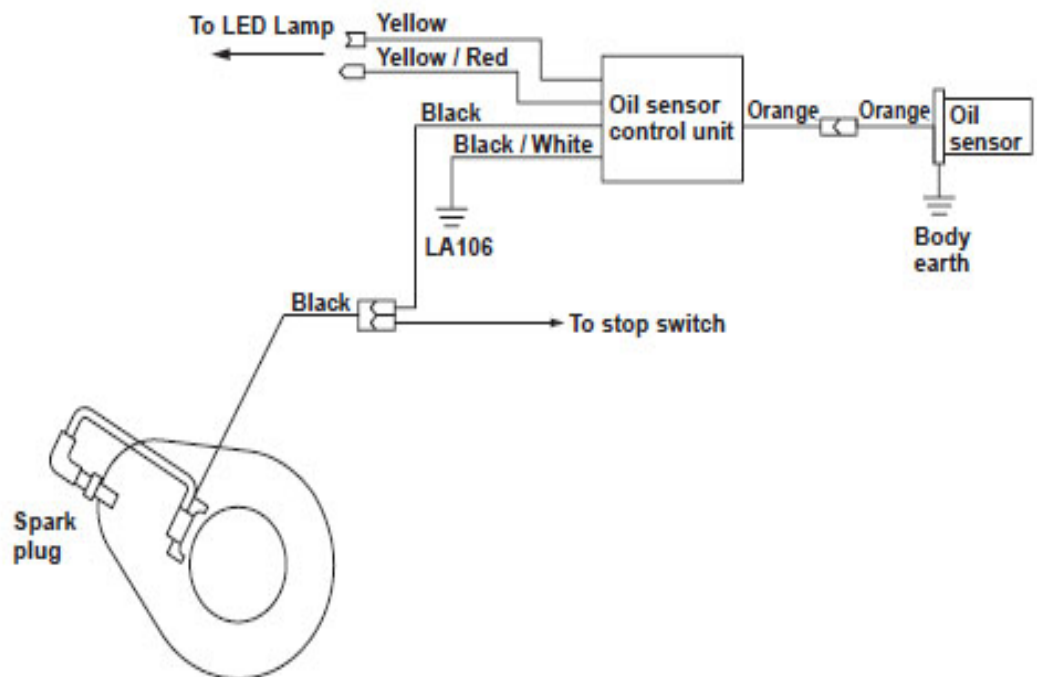

Fig. 8-1

8-4 MODEL WITH OIL SENSOR



SPECIFICATIONS

Model Number

920/922

DIMENSIONS

Weight

790 lbs. (358.34 kg)

Height

48" (1.22 m)

Length

102" (2.59 m)

Width

53" (1.35 m)

ENGINE

Engine Options

Honda GX270

Subaru EX27

Fuel

Gasoline

Power: hp (kW) at 3600 RPM

H-8.7 hp (6.6 kW)

Power: hp (kW) at 4000 RPM

S-9 hp (6.71 kW)

Fuel Capacity

H-0.95 U.S. gallons (3.6 liters)

S-0.94 U.S. gallons (3.6 liters)

Engine Oil Capacity

H - .63 quart (.60 liters)

S - .63 quart (.60 liters)

HYDRAULIC SYSTEM

Reservoir Capacity

7 U.S. gallons (26.5 liters)

ADDITIONAL SPECS

Splitting Force

20 or 22 ton

Cycle Time: 20 ton

14 seconds

Cycle Time: 22 ton

20 seconds