



**6" Disk Style Brush Chippers**  
Model 660

Machine Serial #	_____
Engine Model & Spec #	_____
Engine Serial #	_____
PTO/Clutch Model & Spec #	_____
Clutch Serial #	_____
Purchase Date	_____
Dealer	_____

---

**Carlton**

J.P. Carlton Company  
Div. D.A.F. Inc.  
121 John Dodd Road  
Spartanburg, SC 29303  
Ph. (864) 578-9335  
Fax (864) 578-0210  
[www.stumpcutters.com](http://www.stumpcutters.com)





**CALIFORNIA**

**Proposition 65 Warning**

**Diesel engine exhaust and some of its constituents are known to the State of California to cause cancer, birth defects, and other reproduction harm.**



**⚠ DANGER**

 **NEVER TOUCH  
MOVING MACHINE  
PARTS!** 

0700301

**⚠ DANGER**

**NEVER** climb, ride on, or hang from this machine in any position or manner while it is in operation, running, or being transported.

**PERSONAL INJURY IS PROBABLE!**

0700303

**⚠ DANGER**

**NEVER** reach into this area with hands or other objects severe injury, including amputation, could occur.

**NEVER** attempt to service belts or other machine parts until all machine parts have come to a complete stop. **ALWAYS REMOVE KEY BEFORE SERVICING MACHINE.**

0700302

**⚠ DANGER**

 **AIRBORNE CHIPS  
DISCHARGED FROM  
MACHINE MAY BE  
HAZARDOUS**

**NEVER** turn discharge spout in the direction of spectators or structures. **NEVER** allow anyone to be in or in front of discharge area. **DISCHARGE SPOUT** should be secured completely during transport or operation using clamps, pins, or bolts.

0700304

**⚠ DANGER**

**DANGER - REACHING OR KICKING INTO THE FEED HOPPER AREA WHILE MACHINE IS RUNNING WILL CAUSE SEVERE INJURY OR DEATH!**

**DANGER - FEED ROLLERS PULL WOOD INTO CHIPPER CUTTING AREA AND CAN'T TELL A DIFFERENCE IN BODY PARTS AND WOOD!**

**NEVER PUSH OR LAY SHORT PIECES OF WOOD, BRANCHES, OR BRUSH INTO THE FEED ROLLER AREA WITH YOUR HAND OR FOOT. USE A WOODEN PADDLE TO PUSH SHORT PIECES OF MATERIAL INTO FEED WHEELS OR LAY IT ON TOP OF LARGER PIECES OF MATERIAL.**

**ALWAYS BE PREPARED TO STOP OR TO REVERSE THE FEED SYSTEM AND BE IN A POSITION TO DO SO.**

**OSHA, ANSI AND THE MANUFACTURER HAVE SPECIFIC SAFETY AND OPERATION PROCEDURES - FOLLOW THEM TO PREVENT SEVERE INJURY OR DEATH!**

**ALL OWNERS AND OPERATORS MUST READ AND UNDERSTAND THE SAFETY AND OPERATING PROCEDURES PROVIDED ON OR WITH THIS MACHINE (DECALS, MANUALS, ETC.)**

0700327



**⚠ DANGER**



**NEVER** perform service between feed wheels without upper feed wheel being raised, blocked, and chained. **YOKE LOCK PIN MUST BE IN POSITION.**

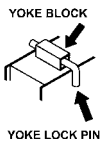

**NEVER** depend on the hydraulic cylinder to hold the upper feed wheel in raised position. The hydraulic cylinder is not a secure method to hold the wheel. **Raise the upper feed wheel using the lift cylinder high enough to fit the yoke lock pin in the yoke block.**

**NEVER PERFORM SERVICE WITHOUT ENGINE TURNED OFF AND KEY REMOVED.**

0720325

**⚠ DANGER**



**MUST FOLLOW THESE GUIDELINES WHEN RUNNING VINE TYPE MATERIAL THROUGH CHIPPER!**

**NEVER** lay vine type material in front of feed hopper!

**NEVER** allow yourself or your clothing to become tangled in or tripped by vine type material. **SEVERE INJURY COULD OCCUR!**

**ALWAYS** cut vine type material into shorter, easier to handle pieces, approximately 4 to 5 feet!



**STOP** automatic feed system and run short pieces of vine type material through chipper using manual start/stop controls and a wooden push paddle!

**STAY ALERT!** Stand near feed control handle and be prepared to use if necessary!

0720296

**⚠ DANGER**

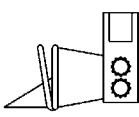
**INJURY OR DEATH CAN BE PREVENTED!  
 OPERATE THIS MACHINE ONLY IF:**

- All personnel are completely trained and understand the operating and shut down procedures.
- ANSI Z133 AND OSHA 29-1910 STANDARDS, concerning personal safety gear and proper clothing, are observed.
- Operators stay alert and are prepared to operate the feed control bar.
- Safety guards and covers are installed and tightened properly.
- Factory supplied or approved parts are installed.
- All safety and machine controls are fully functional.
- Operator reads and fully understands all decals.
- Decals are properly installed, visible, and readable.
- Chipper hood is not opened when machine is running.

**BE SAFE!** Always read and follow all safety instructions and operating procedures provided in manuals, on decals, video, and ANSI Z133 and OSHA 29-1910 standards. Always keep hands, feet and all other body parts out of feed hopper when feed wheels or machine are running .

0700307





## **⚠ WARNING**

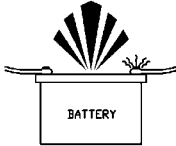

**USE CAUTION IN  
EXTREME COLD!  
FROZEN BATTERY  
WILL EXPLODE!**

NEVER JUMP START A BATTERY IN FREEZING TEMPERATURES. INSPECT BATTERY FOR SIGNS OF FROST BEFORE STARTING IN EXTREME COLD. MOVE EQUIPMENT TO A HEATED, WELL VENTILATED AREA TO ALLOW BATTERY TO THAW BUT NOT NEAR FIRE, SPARKS, OR OTHER SOURCES OF IGNITION.

BATTERY FUMES ARE EXPLOSIVE. NEVER USE JUMPER CABLES OR RECHARGE BATTERY UNLESS IN AN OPEN OR WELL VENTILATED AREA AND AWAY FROM ALL SOURCES OF IGNITION. BATTERY ACID CAN CAUSE SEVERE BURNS. KEEP AWAY FROM EYES, SKIN, AND CLOTHING.

ALWAYS REMOVE BATTERY BEFORE WELDING ON EQUIPMENT. FOLLOW PROCEDURES FOR WELDING AND GROUNDING BEFORE STARTING TO WELD ON THIS MACHINE OR EQUIPMENT DAMAGE AND POSSIBLY SEVERE PERSONAL INJURY WILL OCCUR.

0700314

## **⚠ WARNING**



### **FLAMMABLE FUEL**

THIS MACHINE USES DIESEL FUEL AND HYDRAULIC OIL.

NEVER FILL TANK WHILE ENGINE IS HOT, RUNNING, OR IN A CONFINED AREA. DANGER OF FIRE OR EXPLOSION EXIST.

LEAVE ROOM IN THE TANK FOR EXPANSION FROM HEAT - NEVER FILL TANK COMPLETELY FULL.

KEEP MACHINE AWAY FROM FIRE, SPARKS, AND OTHER SOURCES OF IGNITION DURING USE AND STORAGE.

NEVER PUT MACHINE IN STORAGE WITH FUEL IN THE TANK.

ALWAYS STORE FUEL IN APPROVED (RED) CONTAINERS AND AWAY FROM SOURCES OF IGNITION.

0700316

## **⚠ WARNING**



**LOUD NOISE! FLYING DEBRIS!  
HEARING AND EYE PROTECTION  
MUST BE WORN WHILE IN  
OPERATION!**

PROTECT YOUR HEARING AND SIGHT AND WEAR APPROVED SAFETY AND PERSONAL PROTECTION EQUIPMENT. OSHA AND ANSI SAFETY STANDARDS SHOULD BE FOLLOWED CLOSELY.

0700321

## **⚠ WARNING**

**SEVERE ENGINE DAMAGE  
WILL OCCUR IF THIS  
ENGINE IS OPERATED AT  
AN ANGLE GREATER  
THAN 25°**

PROPER ENGINE OIL LEVEL  
MUST BE MAINTAINED TO  
ACHIEVE MAXIMUM ANGLE OF  
OPERATION OF 25°  
(SEE ENGINE OWNER'S MANUAL  
FOR PROPER OIL LEVEL)

0700075A

## **⚠ WARNING**



### **KEEP AWAY FROM PRESSURIZED LEAKS**

Pressurized leaks are not always visible. Check for pressurized leaks using cardboard or wood. Never use a finger, hand or other body part to check for leaks.

Injuries from pressurized leaks penetrating the skin will lead to serious health problems or death. CONSULT A PHYSICIAN IMMEDIATELY IF PENETRATION OCCURS, SURGICAL REMOVAL REQUIRED.

Release pressure from line before loosening, removing or replacing any hydraulic hoses or equipment.

0700317



# NOTICE

**REGULARLY ADJUST  
AND GREASE  
PTO/CLUTCH PER  
MANUFACTURER'S  
MANUAL**

0700308

# NOTICE

DECALS SHOULD BE PROPERLY MAINTAINED AND REPLACED. IT IS THE DUTY OF THE OWNER OF THIS EQUIPMENT TO KEEP DECALS IN GOOD CONDITION.

REPLACEMENT DECALS MAY BE PURCHASED FROM  
J. P. CARLTON CO.

0700309

# NOTICE

## **NEVER ENGAGE OR DISENGAGE CLUTCH AT HIGH ENGINE SPEEDS IN EXCESS OF 1200 RPM!**

FOLLOW PTO/CLUTCH MANUFACTURER'S MANUAL FOR PROPER MAINTENANCE PROCEDURES AND LUBRICATION SCHEDULES. DO NOT OPERATE THIS EQUIPMENT UNLESS PROPER SERVICE IS PERFORMED. BE SURE TO FOLLOW THE PROCEDURES FOR YOUR BRAND AND MODEL AS SERVICE AND OPERATION VARIES BY BRAND AND MODEL. NEW PARTS AND EQUIPMENT MAY REQUIRE SERVICE SOONER AND MORE OFTEN.

## **WELL TRAINED OPERATORS DON'T COST YOU MONEY!**

POOR MAINTENANCE PRACTICES WILL COST YOU MONEY, MAKE SURE ANYONE WHO OPERATES THIS MACHINE IS FAMILIAR WITH THE MAINTENANCE AND LUBRICATION PROCEDURES. A WELL MAINTAINED AND CORRECTLY ADJUSTED CLUTCH SHOULD PROVIDE MANY YEARS OF SERVICE WITH LITTLE COST. LACK OF PROPER MAINTENANCE AND LUBRICATION WILL CAUSE THE CLUTCH TO FAIL PREMATURELY.

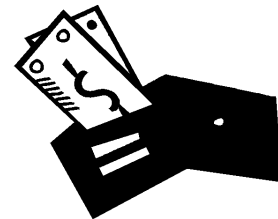

0700312

# NOTICE

## **IMPORTANT MAINTENANCE**

- **REPLENISH RADIATOR COOLANT DAILY WHEN ENGINE IS OFF AND COLD. KEEPING THE ENGINE COOL AIDES IN LONG ENGINE LIFE. READ AND FOLLOW ENGINE MANUAL FOR COOLANT TYPE AND OTHER ADDITIVES.**
- **CLEAN ENGINE COOLING SYSTEM REGULARLY. (SUCH AS COOLING FANS, AIR COOLED ENGINE SHROUD, AND FILTER SCREENS, ETC.)**
- **BLOCKED FINS WILL KEEP RADIATOR FROM COOLING ENGINE SUFFICIENTLY. PRESSURIZED WATER SHOULD BE USED ONCE OR TWICE DAILY TO CLEAN RADIATOR FINS COMPLETELY. ALL DEBRIS MUST BE REMOVED FROM FINS. USING AIR PRESSURE WILL NOT CLEAN COMPLETELY.**

**ENGINE WILL OVERHEAT AND FAILURE WILL OCCUR IF RADIATOR AND COOLING EQUIPMENT ARE NOT MAINTAINED OR SERVICED CORRECTLY OR IF NEGLECTED.**

0700328



# NOTICE

## LUBRICATION AND HYDRAULICS CHECKLIST

ONLY TEXACO STARPLEX II GREASE OR EQUIVALENT SHOULD BE USED.

FOLLOW THE GUIDELINES IN THE LUBRICATION SECTION AND CHART IN THE MANUAL.

PTO/CLUTCH AND ENGINE SHOULD BE SERVICED AS SPECIFIED IN THE OWNER'S MANUALS FOR EACH.

REPLACE HYDRAULIC FILTER AFTER FIRST 10 HOURS OF OPERATION AND EACH 400 HOURS AFTERWARD.

HYDRAULIC TANK SHOULD ALWAYS BE KEPT 7/8 FULL. INCORRECT OIL TEMPERATURE OR PRESSURE MAY CAUSE CAVITIES TO FORM IN PUMP THUS CAUSING FAILURE AND EXPENSIVE REPAIRS.

PREMATURE FAILURE MAY OCCUR IF HYDRAULICS ARE NOT ALLOWED TO CIRCULATE SLOWLY A MINIMUM OF 5 MINUTES TO WARM UP IN COLD WEATHER.

TIGHTEN BELTS PROPERLY, LOOSE BELTS CAUSE SLIPPING AND HYDRAULIC POWER LOSS AND OVERLY TIGHT BELTS CAUSE BROKEN PUMP SHAFTS. CHECK MANUAL FOR PROPER BELT TENSION.

FAILURE DUE TO POOR HYDRAULIC AND BEARING MAINTENANCE IS VISIBLE AND WILL VOID WARRANTY!

**REFER TO MANUAL FOR MORE INFORMATION**

0700310

# NOTICE

## SERVICING BELTS AND BEARINGS

ALWAYS TURN OFF ENGINE AND REMOVE KEY BEFORE SERVICING! ALLOW ALL PARTS TO COME TO A COMPLETE STOP AND COOL BEFORE TOUCHING!

- New belts stretch and get loose. After 2 hours of operation, check tension and tighten belts.
- Check tension and retighten every 4 hours of operation until tension stays consistent.
- See manual for instruction and proper tension.
- Thereafter, check belt tension every month until belts need replacing.

### AT LEAST ONCE A MONTH:

- CHECK AND TIGHTEN BOLTS AND LOCK SETSCREWS ON ALL BEARINGS.
- CHECK AND TIGHTEN SCREWS ON ALL BELT PULLEY BUSHINGS.

**REFER TO MAINTENANCE SECTION**

0700311

# NOTICE

## REPLACEMENT KNIFE AND HARDWARE SHOULD BE FACTORY APPROVED

ALWAYS use correct torque when retightening or replacing chipper knife or other hardware as specified in manual.

REPLACE chipper knife bolts and nuts that have been tightened numerous times - tighten no more than 5 times.

ALWAYS replace chipper knife, holders, bolts, and nuts with factory issued or approved parts for this machine (see manual).

ONLY sharpen chipper knife as specified in manual. Never go below minimum width.

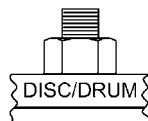

INSTALL chipper knife hardware correctly. The nut goes next to the chipper disc/drum with the flat side of the nut next to the disc/drum.

0700313





# CHIPPER LIMITED WARRANTY

J. P. Carlton Co. Inc., hereafter referred to as the “Manufacturer”, warrants each new Carlton Chipper to be free of defects in workmanship and material for a period of one year.

This warranty takes effect upon delivery to the original retail purchaser. The manufacturer at its option will replace or repair at a point designated by the manufacturer, any parts which appear to have been defective in material or workmanship. The manufacturer is not responsible for consequential damages.

This warranty will be valid *only* if the chipper is operated in a manner recommended by the manufacturer. The following examples would void warranty:

1. The chipper has been abused. (Such as over extending size limits, not following routine maintenance recommendations, etc.)
2. The machine is involved in or damaged by an accident.
3. Repairs or attempted repairs were made without prior written authorization. Including, but not limited to, repairs made due to normal wear or not using manufacturer approved replacement parts.
4. Chipper damaged by foreign materials. (Such as wire, metals of any kind, etc.)

The owner is responsible for all regular maintenance as explained in the operator’s manual. Neglect in regular maintenance or failure to replace normal wear items such as knives, anvil, lubrication oils, filters, belts, bearings, etc. may void warranty.

This warranty is expressly in lieu of any other warranties, expressed or implied, including any implied warranty or merchantability of fitness for a particular purpose and of any non-contractual liabilities including product liabilities based upon negligence or strict liability. J. P. Carlton Co. Inc. will not be liable for consequential damages resulting from breach of warranty.

IT IS NECESSARY TO RETURN THE WARRANTY VALIDATION FORM AND NOTIFY J. P. CARLTON CO. INC. IN WRITING WITHIN TEN (10) DAYS FROM DELIVERY DATE TO VALIDATE THIS WARRANTY.

NOTE: This warranty applies only to new and unused equipment or parts thereof manufactured by J. P. Carlton Co. Inc. ANY MACHINES USED FOR LEASE OR RENTAL – WARRANTY IS LIMITED TO 90 DAYS FROM FIRST DAY OF INITIAL SERVICE.

**NOTICE: All power units and associated components are NOT warranted by J. P. Carlton Co. Inc. or their dealers. It is the customer’s responsibility to return the machine to the local engine distributor.**

**Information phone numbers to find your local engine & parts service centers:**

- Honda ..... 1-770-497-6400**
- Kohler Engines..... 1-800-544-2444**
- Briggs & Stratton Engines..... 1-800-233-3723**
- Lombardini ..... 1-770-623-3554**
- Deutz Engines..... 1-800-241-9886**
- John Deere Engines ..... 1-800-533-6446**
- Caterpillar ..... 1-877-636-7658**
- Kubota ..... 1-847-955-2500**
- Kawasaki Engines..... 1-616-949-6500**
- Wisconsin Engines ..... 1-800-932-2858**
- Onan Engine ..... 1-800-888-6626**

In order to process any claims, it is the owner's responsibility to report claims properly to the manufacturer or the authorized dealer from whom the equipment was purchased. It is necessary to include the following information on any and all request for warranty:

- |                               |                                  |
|-------------------------------|----------------------------------|
| 1. Dealer from whom purchased | 5. Engine make and serial number |
| 2. Date of delivery           | 6. Length of time in use         |
| 3. Serial number of unit      | 7. Date of failure               |
| 4. Model number of unit       | 8. Nature of failure             |





### **EXPLANATION OF LIMITED WARRANTY**

The manufacturer will not reimburse the customer or dealer labor cost incurred for installing “bolt-on” or “slip-on” items, such as pumps and motors, bearings, belts, pulleys, etc. The manufacturer will provide replacement parts at no cost to the customer for defective parts during the warranty period. Defective parts must be returned to J. P. Carlton Company. It will be the customer’s responsibility to install the replacement parts unless arrangements are made with the selling dealer.

The manufacturer will not reimburse travel cost to servicing dealer. It is the customer’s responsibility to deliver the machine to the dealer’s facility, unless other arrangements have been agreed to between the selling dealer and the customer.

The manufacturer may elect, at its discretion, to reimburse reasonable labor cost to customer or dealer for major defect repairs. Prior approval must be obtained from J. P. Carlton Company Inc.

### **IMPORTANT NOTICE**

1. AIR FILTER MAINTENANCE IS CRITICAL ON CHIPPERS. DIRT INGESTION WILL NOT BE WARRANTED BY THE ENGINE MANUFACTURER OR BY J. P. CARLTON COMPANY.
2. OIL AND OIL FILTER MAINTENANCE ARE CRITICAL ON CHIPPERS. STARVING THE ENGINE FOR OIL WILL NOT BE WARRANTED BY THE ENGINE MANUFACTURER OR BY J. P. CARLTON COMPANY.
3. IF THE CHIPPER IS EQUIPPED WITH A CLUTCH, THE MAINTENANCE AND ADJUSTMENT ARE CRITICAL; FOLLOW THE CLUTCH MAINTENANCE AND ADJUSTMENT SECTIONS IN THIS MANUAL. J. P. CARLTON CO. DOES NOT WARRANT THE CHIPPER CLUTCH. READ THE CLUTCH MANUAL FOR THE MANUFACTURER’S WARRANTY.



## Warranty Validation Form

Congratulations on your purchase of a Carlton Chipper. This product has been designed and manufactured to provide years of profitable service while minimizing maintenance and downtime. Please take the time now to complete this warranty validation form. This information is necessary for Carlton to instate your warranty.

Return Form To: J. P. Carlton Company, Div. D.A.F. Inc.  
121 John Dodd Road; Spartanburg, SC 29303; Phone: 1-864-578-9335

### Purchaser Information:

Company Name: \_\_\_\_\_ Street Address: \_\_\_\_\_  
City: \_\_\_\_\_ State: \_\_\_\_\_ Zip Code: \_\_\_\_\_  
Telephone: \_\_\_\_\_ Contact Name: \_\_\_\_\_

### Machine Information:

Model Number: \_\_\_\_\_ Engine Model: \_\_\_\_\_  
Serial Number: \_\_\_\_\_ Serial Number: \_\_\_\_\_

### Dealer Information:

Dealer Name: \_\_\_\_\_ Street Address: \_\_\_\_\_  
City: \_\_\_\_\_ State: \_\_\_\_\_ Zip Code: \_\_\_\_\_  
Telephone: \_\_\_\_\_ Contact Name: \_\_\_\_\_

1. \_\_\_\_\_ Customer has been instructed on the operation and safety of this chipper.
2. \_\_\_\_\_ Customer understands it is the chipper owners' responsibility to train all operators on all aspects of operator safety and operation of this chipper.
3. \_\_\_\_\_ Customer has been instructed that every person within a 100 foot radius of the chipper while in operation must be wearing personal safety equipment as specified in the Safety Section of this manual.
4. \_\_\_\_\_ Customer has been instructed on positioning the discharge chute away from the direction of people and/or property because of the danger of airborne chips.
5. \_\_\_\_\_ Customer has been **warned that no one should ever reach, kick or lean into the feed intake chute.** Customer has been informed that at least one operator must be in position, at all times, to activate the feed control bar to shut down and reverse the feed wheels any time material is being fed or the feed wheels are running.
6. \_\_\_\_\_ Customer has been instructed to feed short brush or vine-like material on top of longer material or to use the push paddle, not to reach or kick this material into the chipper feed intake chute.
7. \_\_\_\_\_ Customer has been warned not to operate the chipper with the chipper hood open or unlocked. The chipper hood must be pad locked and must not be able to come open during operation.
8. \_\_\_\_\_ Customer has been instructed on the procedures to follow before performing maintenance of any kind on the chipper: turn engine off and remove ignition key; disconnect battery cable; allow the cutter disk to come to a complete stop (which will take several minutes); install cutter disk lock; and allow all parts to cool completely. If working between feed wheels, raise upper feed wheel using the hydraulic lift, insert yoke pin and put wooden block between feed wheels.
9. \_\_\_\_\_ Customer has been instructed on normal maintenance and lubrication schedules and procedures and has been advised that failure to perform periodic maintenance may void the warranty. Oil and air filters must be maintained properly or the warranty will be voided.
10. \_\_\_\_\_ Customer has been advised that the engine or power unit that is used on this machine is warranted by the engine manufacturer and **NOT J. P. Carlton Company.** All engine warranty issues should be addressed to the local engine dealer.
11. \_\_\_\_\_ Customer has been advised that maintenance and adjustment on the clutch are critical. Customer has been advised that J. P. Carlton Co. does not warrant the clutch and the only warranty that applies is in the clutch manufacturer's manual. Contact the clutch manufacturer with warranty issues.
12. \_\_\_\_\_ All operation and warning decals are properly displayed on equipment and have been reviewed with the customer. All safety devices have been inspected and found to be working properly at this time.
13. \_\_\_\_\_ Customer has received and reviewed all operators' manuals, warranties, safety instructions, and parts.
14. \_\_\_\_\_ Customer fully understands all information that has been provided, both written and verbal.

I have inspected this equipment and find it in good working condition. To the best of my knowledge, the customer and his personnel are aware of the above procedures.

Date: \_\_\_\_\_ Signed: \_\_\_\_\_  
Dealer Representative

The equipment has been thoroughly checked by the above named dealer, and I am satisfied with his instructions.

Date: \_\_\_\_\_ Signed: \_\_\_\_\_  
Customer



**INTRODUCTION**

FOREWORD	1
GENERAL INFORMATION	2
MACHINE FEATURES	3
MACHINE SPECIFICATIONS	4

**OPERATION**

SAFETY PRECAUTIONS	5
DAILY CHECKLIST	10
MACHINE CONTROLS	15
TOWING GUIDE	19
MACHINE OPERATION	22

**MAINTENANCE**

MACHINE MAINTENANCE	32
LUBRICATION	37
TROUBLESHOOTING GUIDE	40
SERVICING HYDRAULICS	43
SERVICING CUTTER SYSTEM	45
SERVICING BELTS	58
SERVICING FEED WHEEL MOTOR	67
MACHINE WIRING	72

**PARTS**

DECAL ASSEMBLY	73
PARTS BOOK	

**MISCELLANEOUS**

AUTO-FEED PLUS® MANUAL	
E-Z LUBE® MAINTENANCE	
BACK	



Congratulations on your purchase of a new Carlton® Professional Chipper! Carlton® has built its reputation on the superior performance and reliability of their stump grinders and you can be assured your new chipper has the same performance and reliability. A machine is not profitable if it's broken-down and we do our absolute best to help you avoid costly downtime. Each and every machine has been *over* designed and overbuilt to ensure years and years of trouble-free operation. In this, we take pride.

The Carlton® 660 chipper is the heaviest duty 6-inch capacity disk style chipper available. From the ground up, the components and weldments are the strongest on the market.

Read this manual carefully and TAKE RESPONSIBILITY for thoroughly familiarizing yourself with the controls and the concepts behind the operation of this machine before attempting to operate it. Slowly experiment with the controls and gradually work yourself up to the full capabilities of this machine. The Carlton® 660 chipper is a durable and profitable professional chipper. Read the chipper manual, the safety and operational decals on the chipper, and all other operation and safety materials provided for the engine and other components. Use proper safety precautions. Follow the instructions and use common sense and your "OX" will perform like its namesake. If getting more work done in a day, with less trouble, is your idea of good business, then you'll love your new Carlton® Chipper.

We welcome your suggestions on how we might better build our machines. We solicit any and all questions concerning the safe operation or proper servicing of your new chipper.

Please feel free to write to us with any comments.  
We'll enjoy hearing from you!





The J. P. Carlton Company constantly strives to create the best professional tree equipment available in the industry. Therefore, the material in this manual is correct at the time of publication. Carlton® reserves the right to make improvements, modifications, and even discontinue features as we deem necessary to meet our goal. Carlton® also reserves the right to discontinue models without any prior notification or obligation.

Inspect your new Carlton® Chipper as soon as you receive it. Any damages incurred during shipment are not warranted and, therefore, are not covered repairs. You should have the truck driver verify or acknowledge any damages caused during shipment. If not, contact the truck lines as soon as possible with your complaint.

Any reference made to the right, left, front, or rear in relationship to the chipper is illustrated in the following pictures. Please refer to these any time you call your dealer or J. P. Carlton for parts or assistance.

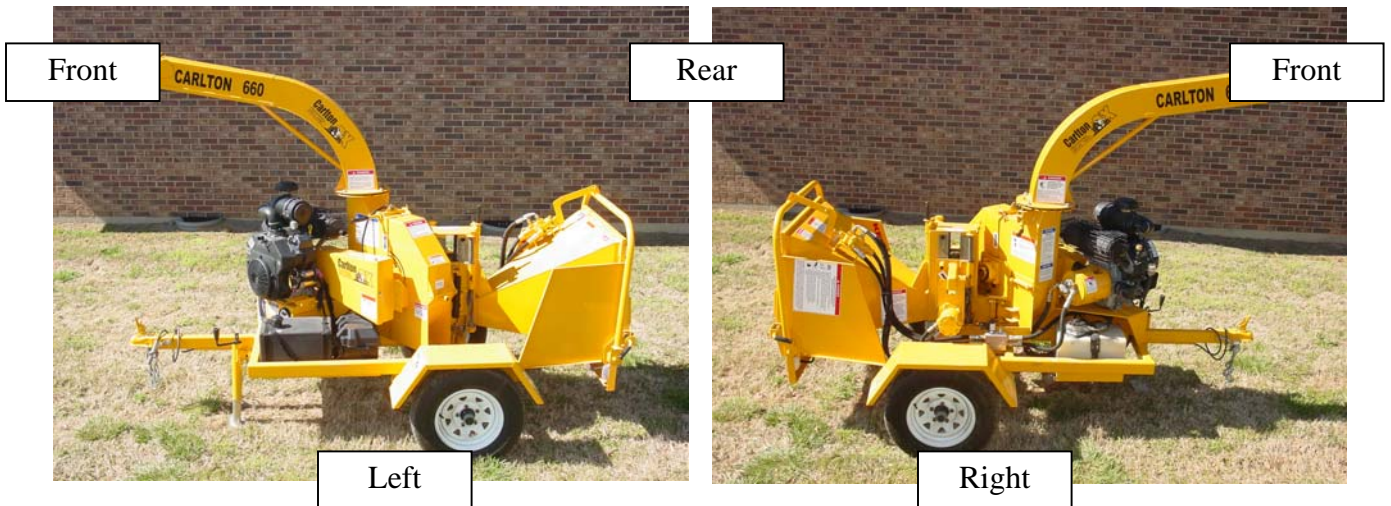



**Available Machine Features:**

- 27 HP gas engine
- Auto-Feed® Plus system
- Direct drive hydraulic pump
- 360° adjustable swivel discharge w/adjustable deflector
- Axle 2000# cap
- Electric brakes, optional
- Front jack stand – 2000# Cap, Screw type
- AR400 anvil
- 13" Tires rated 1760 pounds @ 50 PSI
- Tapered roller bearings
- 1-1/2" thick cutter disk
- 2 knives
- 6" x 6" throat opening
- 44 1/4" wide feed intake opening
- Top feed roller – 6" x 6"
- Engine Key start
- High capacity battery
- Marine battery box
- Epoxy primer
- Dupont Imron® paint
- Double wire braid hoses

**We Pride Ourselves  
in the strength and quality of each and every machine**



# 6" CHIPPER

# MACHINE SPECIFICATIONS

## General:

Weight: 1600 Pounds  
Length: 124 inches  
Height: 87 inches  
Width: 56 inches  
Tires: ST175/80R13 Ld Rng C 1760 # @ 50 PSI  
Axle: Dexter Torflex 2,000 Pound Cap  
Brakes: Electric Available as Option  
Hitch: 2" Coupler  
Fuel Capacity: 6 Gallons  
Battery: 850 CCA 78DT - 72  
Jack Stand: 2000 # Cap Screw Type Swing Up

## Engine:

Manufacturer: Kohler Model CH740  
Number of Cylinders: Two  
Bore: 3.27 Inches (83 mm)  
Stroke: 2.64 Inches (67 mm)  
Displacement: 44 Cubic Inches (725 cc)  
Maximum RPM: 3600 RPM  
Horsepower: 27 HP  
Torque: 42.7 Ft\*Lbs @ 3,000 RPM  
Cooling Medium: Forced Air  
Air Cleaner: Two Stage Dry Type  
Oil Filter: Full Flow Spin On  
Oil Capacity: 2.1 Quarts  
Electrical: 12 Volt  
Weight: 94 Lbs (43 KG)

## Bearings:

Disk Bearings: 2 inches Tapered Roller  
Feed Roller Bearings: 2 inches Ball Bearing  
Disk Shaft: 2 1/2 inches Removable  
Feed Roller Shaft: 2 inches

## Chipper Disk:

Wheel Diameter: 26 inches  
Wheel Thickness: 1 1/2 inches  
Disk Balance: Precision High Speed Balanced  
Wheel Speed: 1850 RPM Nominal  
Number of Knives: 2  
Knife Dimensions: 7 1/4" x 4 x 1/2"  
Anvil: 3" x 6" x 1/2" AR400  
Chip Throwers: Two 1/4" x 3 1/2" x 3 1/2" x 9 1/2" long

## Cutting Dimensions:

Throat Opening: 6" x 6"

## Hydraulic System:

Hyd Pump Displcmnt: .329 in cu/rev  
Hyd Pump Drv Systm: Direct Drive off Engine Mount  
Flow: 5.33 GPM  
System Relief: 2500 PSI  
Oil Tank Capacity: 6 Gallons  
Oil Type: AW32  
Valve: Series Type  
Hose: 16,000 PSI Burst - Exceeds SAE 100R2  
Oil Filter: 10 Micron in Tank Return Filter

## Drive System:

Engine Sheave: 6/3V5.3  
Jackshaft Sheave: 6/3V10.6  
Drive Belt: 6/3V630 Kevlar Powerband  
Cutter Head Shaft: 2 1/2 inches

## Feed System:

Feed Motors: 22.8 in cu Top  
Flow: 5.33 GPM  
Hydraulic Drive: Live - Driven off engine  
Autofeed: Digital Fully Adjustable  
Feed Rate: 80 Feet Per Minute  
Feed Rollers: Top 10-1/2" x 6"  
Springs: 15" Tight Wound Powder Coated  
Slide Bearings: Four 1" Hardened Replaceable  
Discharge: 360 Adjustable Swivel w/Deflector

## Frame:

Main Trailer Tongue: 2"x 3" with 3/16" wall  
Main Trailer Frame: 2"x3" with 3/16" wall  
Telescoping Tongue: N/A  
Engine Mount: Sliding Positive Lock Engagement  
Infeed Chute: 12 Gauge with 1" tube frame  
Folding Infeed Tray: 10 Gauge with 1" tube frame  
Folding Tray Lock: Two 3/4" Spring Loaded Pin  
Discharge Chute: 12 gauge  
Discharge Lock: 3/4" Spring Loaded Pin  
Fuel Tank: High Density Polyethylene rubber mtd  
Hydraulic Tank: High Density Polyethylene rubber mtd  
Battery Box: Marine Battery Box  
Fenders: 12 gauge  
Feeder Bar: 1" OD x .093" wall - removable  
Radiator Guards: None  
Light Brackets: 10 Gauge

Before operating the chipper, read this manual, the engine manual, and all the safety decals on the machine. Know all parts of the machine and their functions, especially the shut down procedures in case of emergency. No inexperienced person may operate the chipper. Inexperience may cause injury. It is the owner's responsibility to ensure all operators are trained and fully understand all safety and operational aspects of the chipper.

This machine was built with safety in mind. The guards and other safety devices only work when kept in place and secured properly. Safety decals are placed on the machine as reminders of how to operate the machine safely, pay attention to the instructions.

**SAFETY FIRST ALWAYS!**

This is the **Safety-Alert Symbol**. This symbol is placed on the machine and in the manual to alert the operator to the potential for bodily injury or death. The operator should pay close attention to the instructions whenever they see this symbol.



The **Safety-Alert Symbol** will be accompanied by one of the following words: **DANGER, WARNING, or CAUTION**

- A **DANGER** symbol means that if the instructions are not followed the possibility of serious personal injury or death is probable.
- A **WARNING** symbol means that if the instructions are not followed there is a possibility of serious personal injury or death.
- A **CAUTION** symbol means there is an unsafe condition or practice that may cause personal injury or property damage.

**PERSONAL PROTECTION:**

- ❖ All personnel must wear eye and ear protection, hard hat, short fitted gloves without cuffs, long sleeve shirt, long pants without cuffs, and over the ankle work boots with skid resistant soles
- ❖ Do not wear loose-fitting clothing
- ❖ Tie long hair back
- ❖ Do not wear jewelry or long dangling clothing; i.e. neckties, long belts, or chains
- ❖ Stay away from feed wheels
- ❖ Keep away from moving parts
- ❖ Only run in a well ventilated area because of carbon monoxide poisoning

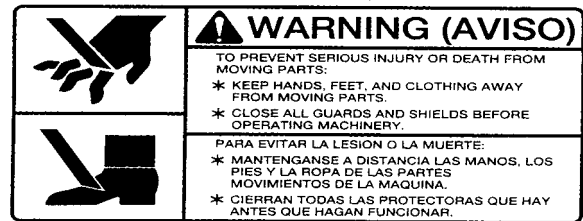

P/N 070000A

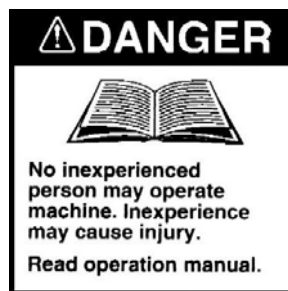

P/N 0700008



P/N 0700010

JPC10

Be Safe and Practice Safe Operation using the following guidelines.

**⚠ DANGER**



- **Any** individual operating this chipper **must** first read and understand this manual, the engine and other component manuals supplied with the chipper, and all safety and operational decals on machine.
- DO NOT permit children to operate machinery or to play near machinery during operation.
- DO NOT allow spectators to stand and watch chipper in operation.
- DO NOT allow people to pass by discharge zone while chipper is in operation.
- Keep hands, feet, legs, clothing, hair and all other body parts away from feed intake wheels, chipper knives, and other moving parts.
- Do not hang from, ride, sit, stand, lay, or climb anywhere on this chipper while it is in operation, running, or being transported.
- Do not move, position, or transport this chipper with the engine running.
- Keep away from pressurized leaks. Never check for leaks using hand or finger, use cardboard or wood. Pressurized fluid can penetrate the skin and cause injury or even death. Seek immediate medical attention if penetration occurs. Always wear eye protection.
- DO NOT operate any machinery while under the influence of alcohol or drugs (prescription, over the counter, or otherwise).
- DO NOT modify or change any part without written approval from J. P. Carlton Company.

**⚠ DANGER**



- No one should ever reach, lean, or kick into the feed intake chute when the chipper or the engine is running. Feed wheels will pull in anything in the path of operation and **will** cause **severe** personal injury if a person is pulled into feed intake wheels.
- Always load shorter pieces of wood or brush on top of longer pieces or use push paddle, **never** reach into the feed intake chute to load these pieces.



- Stay clear of discharge zone when running chipper. Never allow anyone to stand near or to walk close to the discharge zone, even if being discharged into a bin or truck.
- Airborne debris may cause severe injury. If inspection of chipped material is required, shut down the chipper and the engine first.
- Discharge spout should not be pointed toward people, buildings, or other personal property that may be injured or damaged. Airborne debris is as dangerous as any powerful projectile.
- Never position, adjust, or move the discharge chute while the chipper or the cutter disk are running

**⚠ DANGER**

- Always have at least 2 operators at the job site running the chipper. One to load the brush into the feed wheels and the other to maintain the feed control bar in case of an accident.
- Always feed trees and brush butt end first and walking to the right side of the chipper, material being fed should be to the operator's left side. The material being fed tends to kick to the left and could injure anyone on that side.
- Never lean over material being loaded into the feed wheels; especially small diameter, short length material that is still long enough to be fed into the feed wheels alone. The material is not heavy enough to hold down when the feed wheels first grab it and will kick up hitting the operator in the chin or head causing injury.

**⚠ DANGER**



- Never lay vine type material in front of feed intake chute.
- Never allow yourself or your clothing to become tangled in or tripped by vine type material. **SEVERE INJURY COULD OCCUR.**
- Always cut vine type material into shorter, easier to handle pieces, approximately 4 to 5 feet.
- Don't feed the vines into the chipper unless they have been cut!!!
- STOP automatic feed system and run vine type material through using manual start/stop controls and a wooden push paddle.

**⚠ DANGER**



- **KEEP CUTTER DISK HOOD CLOSED WHILE CHIPPER IS RUNNING.** Always make sure the cutter disk hood latch pin is in place and locked securely using a padlock before starting chipper. The cutter disk hood must be locked using the factory issued lock pin and padlock.
- Never open the cutter disk hood while engine is running. After the engine is turned off, allow the cutter disk to come to a complete stop before opening the cutter disk hood. This will take several minutes
- Never run the chipper or the engine with the cutter disk hood open or unlocked at any time or for any reason.
- If the cutter disk hood or hinge is damaged, replace immediately.

**⚠ WARNING**

- Always have the trees and brush cut to size for the chipper before the chipper arrives at the job site.
- It is very dangerous to run a chain saw and the chipper at the same time.
- If a tree gets jammed and has to be trimmed, shut down the chipper first.



**⚠ DANGER**

DO NOT PERFORM MAINTENANCE OF ANY KIND ON THIS MACHINE UNLESS:

- ◆ The engine is turned off
- ◆ The ignition key is removed
- ◆ Positive battery cable is disconnected
- ◆ The clutch is disengaged
- ◆ Feed control bar is in neutral
- ◆ All machine parts have come to a complete stop – NOTE: The cutter disk takes several minutes to come to a complete stop
- ◆ All machine parts have had sufficient time to cool down
- ◆ The cutter disk lock pin is installed in the disk lock tube
- ◆ No operator is in position at the controls to accidentally start machine
- ◆ At least 2 people are at the site where maintenance is performed

**More accidents occur while performing maintenance than any other time! Use extra caution.**

**Never** perform maintenance with the engine running, not even with the clutch disengaged. The pilot bearing could seize or freeze to the clutch shaft and permit the clutch to engage even though the operator thought the clutch had been disengaged.

**ALWAYS REPLACE GUARDS AND OTHER PROTECTIVE EQUIPMENT BEFORE STARTING CHIPPER AFTER PERFORMING MAINTENANCE.**

**⚠ WARNING**

- Keep a well-stocked First Aid Kit with the chipper at all times.
- Keep a full Fire Extinguisher with the chipper at all times.

**⚠ DANGER**



- **YOKE LOCK PIN MUST BE IN POSITION** before performing maintenance between the feed wheels. Use a manual jack to raise upper feed wheel high enough to insert yoke lock pin as shown above.
- **Chipper must be attached to tow vehicle before raising the upper feed wheel.** This will stabilize the chipper during service to keep it from turning over and causing severe injury to workers and damage to the chipper.
- Upper feed wheel springs must be disconnected to raise feed wheel using jack.



- Stop engine, remove key, and disconnect battery cable when repairing or adjusting machine or drive belts.
- Keep engine in good condition, service as instructed in engine manual. Do not touch engine while running or hot (serious burns may result).
- Allow all machine parts to cool sufficiently before servicing or making adjustments. Hot machine parts can cause severe burns.



**⚠ WARNING**

- During operation of the chipper, all people within a 100-foot radius should wear protective equipment, including eye and ear protection and hard hats.
- If unusual noise or vibration occurs, stop engine immediately and correct the problem before continuing operation, consult authorized dealer if necessary.
- Keep all guards in place and properly secured during operation. Never operate the chipper with guards missing or loose.
- Keep all safety devices working properly and all other machine parts in good condition.
- Never leave the controls unattended while in operation. Be sure machine is not capable of operation when left unattended. Remove key and disconnect battery, if necessary.
- **DO NOT OPERATE THE ENGINE AT AN ANGLE GREATER THAN 25° OR SEVERE ENGINE DAMAGE WILL OCCUR. PROPER ENGINE OIL LEVEL MUST BE MAINTAINED TO ACHIEVE MAXIMUM ANGLE OF OPERATION OF 25°. (See Engine Owner's Manual for proper oil level.)**

**⚠ CAUTION**

- Do not operate chipper in dim lit, dark, or concealed areas. Do not operate or run machine or engine in enclosed area due to carbon monoxide poisoning hazard.
- Keep machine clean and clear of debris to eliminate fire hazard. It is especially important to clean any oil or fuel spills to prevent the danger of fire.
- Keep safety and instructional decals clean and replace any that are damaged, difficult to read, or missing. Decals may be purchased from J. P. Carlton or an authorized dealer.
- Remove all foreign objects from the chipper before starting, i.e. jackets, gloves, tools, etc.

**⚠ WARNING**



- Gasoline, diesel fuel and their vapors are highly flammable and explosive. **Handle with care.** Only use approved (red) fuel containers for storage.
- Do not store machine with fuel inside tank or fuel containers near any open flames, sparks, or other sources of ignition.
- Do not store equipment with fuel in the tank for long periods.
- Battery fumes are explosive. Recharge battery in an open area away from fire, sparks, or other sources of ignition.
- Use caution in extreme cold! Frozen battery will explode! Allow battery to thaw in heated area away from fire or sparks.
- Battery acid can cause severe burns. Keep away from eyes, skin, and clothing.
- Remove battery before welding on equipment.

**⚠ CAUTION**

- If operating chipper uncoupled from tow vehicle, the tires and tongue must be blocked. Use but do not depend on jack stands to hold machine steady.
- Always store tools safely away from moving machine parts, especially the feed intake wheels.
- There should be no obstacles in the path of operation behind the chipper or around the chipper to allow trip free movement of all personnel.
- Keep unauthorized persons away from the chipper operation area.

It is vital that the owner and operators inspect the chipper each day before operation. This inspection will help identify potential problems that may arise during the workday. The operators must get in the habit of performing this inspection each and every day. By performing this inspection each day, the operators will help minimize downtime and costly repairs. This inspection will also help to minimize risks associated with the operation of this brush chipper.

**SAFETY:**

**DO NOT PERFORM MAINTENANCE OF ANY KIND (including routine inspections) ON THIS MACHINE UNLESS:**

- **The engine is turned off**
  - **The ignition key has been removed**
  - **The engine belt is disengaged and the lock is in position (see Machine Control section)**
  - **All moving parts have come to a complete stop – NOTE: The cutter disk takes several minutes to come to a complete stop**
  - **The cutter disk lock pin is installed in the disk lock tube**
  - **All machine parts have cooled completely**
  - **There is no operator at the controls to accidentally start the machine**
  - **At least 2 people are at the site where the maintenance is to be performed**
- **Inspect Decals making sure all are in place, secure, and legible.** (Not all decals are shown here just a small representation)



- Make sure all personnel are equipped with all applicable safety equipment:
  - Eye protection
  - Hearing protection
  - Hard hat
  - Short, fitted gloves
  - Long sleeve shirt
  - Long pants
  - Over the ankle work boots with skid resistant soles

**PERSONAL PROTECTION:**

- ❖ **All personnel must wear eye and ear protection, hard hat, short fitted gloves without cuffs, long sleeve shirt, long pants without cuffs, and over the ankle work boots with skid resistant soles**
- ❖ **Do not wear loose-fitting clothing**
- ❖ **Tie long hair back**
- ❖ **Do not wear jewelry or long dangling clothing; i.e. neckties, long belts, or chains**
- ❖ **Stay away from cutter disk**
- ❖ **Keep away from moving parts**
- ❖ **Only run in a well ventilated area because of carbon monoxide poisoning**



BECAUSE OF MACHINE VIBRATION, ALL EQUIPMENT ATTACHED USING SCREWS OR BOLTS AND NUTS SHOULD BE CHECKED REGULARLY FOR TIGHTNESS. ALL SCREWS, BOLTS, AND NUTS NEED TO BE INSPECTED FOR TIGHTNESS AND WEAR. ALL SCREWS, BOLTS, AND NUTS THAT WON'T STAY TIGHTENED OR THAT HAVE WORN, CHIPPED, OR MISSING THREADS SHOULD BE REPLACED.

- Inspect bolts, hydraulic fittings, wiring harnesses, hoses, and equipment for tightness, wear, or leakage. Replace if necessary. DO NOT inspect for hydraulic leaks with your hand or finger.
- **FLUID UNDER PRESSURE CAN PENETRATE THE SKIN AND CAUSE SEVERE INJURY. CHECK FOR LEAKS USING A BOARD OR CARDBOARD; DO NOT USE HAND OR FINGER. SEEK IMMEDIATE MEDICAL ATTENTION IF SKIN IS PENETRATED. ALWAYS WEAR EYE PROTECTION.**





- Check air pressure in tires daily. Inflate to tire manufacturers recommended maximum inflation pressure for temperature and climate.
- Inspect tires for wear.
- Inspect axle caps, replace if necessary. Grease axles as suggested by manufacturer. (Dexter Axle information provided in back of manual.)



- Inspect hitch and hitch bolts. (Bulldog hitch shown; Pintle hitch also available.)



- Make sure all guards are in place and properly secured.



- Check tail and brake lights for proper operation.



- Inspect cutter disk knives and anvil for wear. Do not operate the machine without a full set of undamaged knives in place. Worn or chipped knives will cause improper operation of the chipper. (See Servicing Cutter Disk Section to change or sharpen knives and anvil.)

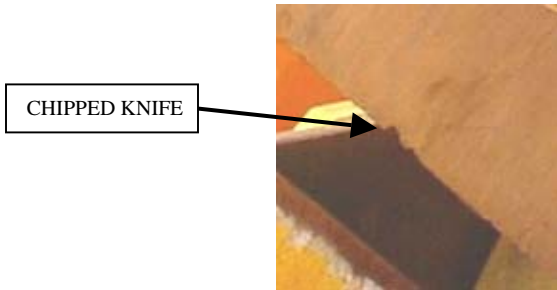

- Cutter disk must rotate freely. This will help insure there are no foreign objects inside the cutting chamber and there is ample knife to anvil clearance. (The cutter disk lock pin will have to be pulled out of cutter disk to check rotation. Replace pin after checking rotation to perform further inspections.)



CHECK FOR GAPS OR DENTS AROUND HOOD

- When inspection of cutter disk is complete, close cutter disk hood, insert hood lock pin and padlock. Make sure hood will not open. Check cutter disk hood and hinges for damage and fit, replace immediately if there is any damage or misalignment.

- Inspect the inside of the infeed chute. Check to make sure there are no foreign objects inside the infeed chute. Anything that is inside of the infeed chute may go through the chipper. There should never be anything or anyone inside the infeed chute when starting the chipper, damage or injury could occur.





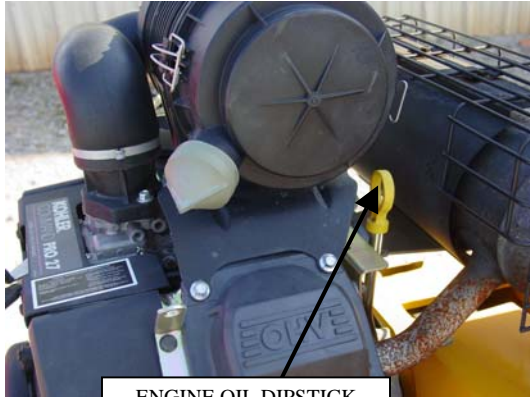

- Check and maintain proper engine oil, fuel tank, and hydraulic oil tank levels. Make sure engine is cool before checking. Replenish engine oil, fuel, and hydraulic oil every morning before starting the machine so there is no danger of fire from hot machine parts or sparks. Do not fill fuel or hydraulic oil tanks more than 7/8 full to allow for heat expansion.

**NEVER REFUEL OR ADD OIL: WHILE ENGINE IS RUNNING, WHILE IN AN ENCLOSED AREA, OR WHILE ENGINE IS HOT.**

- Inspect air filters for dirt and damage, clean or replace as necessary. Open clamp and remove end to remove air filters. Use caution to not allow engine to ingest dirt and debris when changing or inspecting air filters.  
**REPLACE WITH MANUFACTURER RECOMMENDED AIR FILTERS ONLY.**



The proper repair or replacement procedures, if required, are further illustrated in the Maintenance or Service Sections of this manual. Other periodic inspections and maintenance are covered in other sections of this manual.

It is imperative that all operators are familiar with all controls of the chipper. This will make for a much more productive and safer work period. (The actual controls may differ depending on the engine supplied with your chipper.)

**ENGINE CONTROLS:**

- The Kohler engine is started using the key switch located on the engine. The switch has 3 positions: Stop, Run, & Start. (The engine supplied with your chipper may be different, refer to the engine manual for starting information.)
- The engine also has Choke and Throttle controls. For further information about engine operation and service, please read the engine manual supplied with the chipper.

**DO NOT OPERATE THE ENGINE AT AN ANGLE GREATER THAN 25° OR SEVERE ENGINE DAMAGE WILL OCCUR.** PROPER ENGINE OIL LEVEL MUST BE MAINTAINED TO ACHIEVE MAXIMUM ANGLE OF OPERATION OF 25°. (See Engine Owner's Manual for proper oil level.)



- The Auto-Feed Plus® monitors the engine RPM and controls the feed system based on this information. The Auto-Feed is calibrated when installed in the chipper with a high and low RPM setting for the feed wheels to operate. When the engine RPM is low and the Auto-Feed is on, the hydraulics will not work. If large diameter wood is being chipped and the engine RPM drops below the Auto-Feed Low setting, the Auto-Feed will stop the feed wheels. After the engine RPM is high enough to handle the force required to chip this material without causing the engine to lug down, the Auto-Feed restarts the feed wheels.
- The Auto-Feed Plus® control is calibrated to automatically come on when the chipper is started. If you need to turn on the Auto-Feed Plus® control, press and hold the right button down for 4 seconds and release.
- The Auto-Feed must be turned off to operate the hydraulics at low engine RPM or idle. When the Auto-Feed is on the hydraulics only work when the engine RPM is high. To operate the feed wheels at low engine RPM, turn off the Auto-Feed by pressing and holding the left button for 4 seconds and release.
- Read the Auto-Feed Plus® manual supplied at the end of this chipper manual if programming is required.





### CUTTER DISK DOOR LOCKOUT

- The cutter disk door lockout is a safety device that prevents the cutter disk from being engaged if the cutter disk door is not closed or not secured properly. If the pin is not inserted in the door lock, the safety switch cannot be connected and the cutter disk cannot be engaged.

### DISCHARGE FLAP

- There is an adjustable flap on the end of the discharge chute. This flap is adjustable in the vertical direction to help control the height and distance of the chips being discharged. To adjust this flap pull unscrew knob and move flap up or down to desired position. **NEVER ADJUST THIS FLAP WHILE THE CHIPPER IS IN OPERATION OR WHILE THE CHIPPER DISK IS SPINNING!**

### SWIVEL DISCHARGE

- Carlton Chippers are equipped with a rotating discharge chute. To rotate the chute to the desired position
  1. Pull down and unlock the rotation lock pin.
  2. Use the handle on the chute and pull or push the chute in a safe direction to discharge chips or to position the chute for towing.
  3. Release the lock pin making sure it engages in one of the locking slots on the discharge chute securing the chute in desired position.

ALWAYS MAKE SURE THE DISCHARGE IS POINTED IN A CLEAR DIRECTION FOR DISCHARGE OF CHIPS





**FEED CONTROL BAR**

- The feed control bar is located on three sides of the infeed chute; across the top and down each side.
- The feed control bar has three distinct positions
  - In the out position pulled towards the rear of the machine the bar is now in the feed position. In this position the feed wheels are engaged and will pull material into the chipper
  - In the middle position the bar is in the stop position. With the bar in this position the feed wheels are stopped and do not rotate.
  - In the in position pushed towards the front of the chipper the feed control bar is in the reverse mode. This position reverses the feed wheels and attempts to back material out of the chipper.
- **ALWAYS VERIFY CORRECT FUNCTION OF THE FEED CONTROL BAR BEFORE BEGINNING TO CHIP MATERIAL**
- **NO ONE SHOULD EVER REACH, LEAN, OR KICK INTO THE FEED INTAKE CHUTE WHEN MACHINE OR ENGINE IS RUNNING**

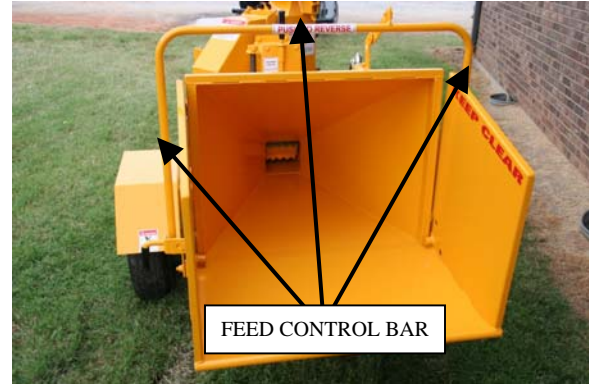

**FRONT JACK STAND**

- Use the front jack stand anytime the chipper is removed from the tow vehicle for storage or rest.
- This chipper cannot be operated as stand-alone. The chipper must be attached to the tow vehicle and the tires chocked when in use.
- The front jack stand can be attached and stored on the left front side of the chipper, as shown.



### **BRAKES & REAR LIGHTS**

- The chipper's lights are connected to the tow vehicle actuator to be activated by the tow vehicle operation.

**See the Machine Wiring section of this manual for wiring diagram.**



**SAFETY:**

- **NEVER ALLOW INEXPERIENCED DRIVERS TO TOW MACHINERY.**
- **ALWAYS MAKE SURE THE TRUCK HITCH AND THE CHIPPER HITCH ARE OF MATCHING STYLE AND SIZE.**
- **ALWAYS MAKE SURE THE TOW VEHICLE AND THE CHIPPER ARE ON LEVEL GROUND AND THE WHEELS ARE CHOCKED BEFORE CONNECTING OR DISCONNECTING THE CHIPPER.**
- **MAKE SURE THE TOW VEHICLE IS OF ADEQUATE SIZE AND HAS THE TOWING CAPABILITY TO SAFELY TOW THE CHIPPER.**
- **NEVER TOW A MACHINE WHILE IT IS RUNNING.**

- Make sure the truck hitch and the chipper hitch are of matching style and size and not worn.
- Check all hitch bolts to make sure they are tight on the chipper and the truck.
- Make sure the hitch on the chipper and the ball on the truck are greased for smoother pivots and to reduce the wear on both parts.
- Make sure the tow vehicle is of adequate size and has the towing capacity to safely tow the chipper. Make sure the truck hitch is heavy enough and built strong enough to tow the equipment.
- Adjust both the truck hitch and chipper hitch so the chipper sits as close to level as possible when connected to the truck. A proper amount of tongue weight is required to allow the machine to tow properly. Too little tongue weight will result in wandering, fishtailing, or axle damage.
- Connect safety chains to a secure position on the tow vehicle. Crisscross safety chains for support in the event of hitch failure. Chains may be twisted to shorten to compensate for excessive length. If the tongue should contact the ground at highway speeds, the machine may dig in and catapult the machine into traffic. **USE YOUR SAFETY CHAINS.**



CHIPPER SHOULD RIDE AS CLOSE TO LEVEL AS POSSIBLE WHEN TOWING



- Connect chipper lights to the tow vehicle. Observe light operation to insure correct electrical connections.



- Secure the jack stand to the machine for towing.



- The chipper infeed tray must be closed and locked when towing.

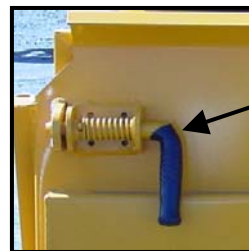

SPRING LOCK PINS

- Make sure the discharge chute is over the chipper front for towing. Position the deflector, on the end of the discharge chute, down when towing to reduce the chance of debris flying out of the chute.



- Always chock the wheels when the chipper is parked, even when attached to the tow vehicle. Make sure the chock blocks have been removed before towing the chipper.
- Towing will affect handling, allow for extra stopping distances.
- Start and stop gradually.
- Tow at a safe, reasonable speed. Obey posted speed limits.
- Slow down over rough terrain.

**STARTING – READ THIS MANUAL, THE ENGINE OWNERS’ MANUAL, THE CLUTCH MANUAL, AND ALL SAFETY DECALS ON CHIPPER BEFORE STARTING.**

**SAFETY:**

- **DO NOT ALLOW CHILDREN OR OTHER SPECTATORS TO STAND AND WATCH THE CHIPPER IN OPERATION. ALL OPERATORS MUST WEAR RECOMMENDED PROTECTIVE EQUIPMENT.**
- **DO NOT ALLOW ANYONE TO BE IN CHIP DISCHARGE ZONE WHILE MACHINE IS RUNNING.**
- **NEVER REACH OR KICK INTO THE INFEED CHUTE FOR ANY REASON.**
- **KEEP CHIPPER HOOD CLOSED WHILE MACHINE IS RUNNING. ALWAYS MAKE SURE CUTTER DISK HOOD HAS LATCH PIN IN POSITION AND LOCKED WITH A PADLOCK, AND IS NOT CAPABLE OF BEING OPENED.**
- **AN OPERATOR MUST ALWAYS BE IN POSITION AND BE PREPARED TO OPERATE THE FEED CONTROL BAR TO REVERSE OR STOP THE FEED WHEELS IF NECESSARY.**
- **ALWAYS BE ATTENTIVE AND AWARE OF THE CHIPPERS OPERATION AND NEVER ALLOW YOURSELF OR ANYONE TO BECOME PULLED INTO THE FEED WHEELS.**
- **ALWAYS LOAD SHORT PIECES OF BRUSH ON TOP OF LONGER PIECES OF WOOD AND BRUSH. NEVER FEED LONG VINE TYPE MATERIAL INTO CHIPPER. ALWAYS CUT INTO SHORT PIECES TO FEED VINE TYPE MATERIAL. THIS MATERIAL COULD TANGLE AND WRAP AROUND SOMEONE OR SOMETHING AND PULL IT INTO THE CHIPPER.**
- **NEVER OPERATE MACHINERY WHILE UNDER THE INFLUENCE OF ALCOHOL OR DRUGS, (PRESCRIPTION, OVER THE COUNTER OR OTHERS).**



**START-UP PROCEDURES:**

- Check all fluids before starting.
- Daily Checklist must be completed before starting.
- Cutter disk hood and all other guards must be in place and secured properly before starting.
- All personnel must be wearing protective equipment: eye and ear protection; hard hat; short fitted gloves without cuffs; long sleeve shirt; long pants without cuffs; and over the ankle work boots with skid resistant soles.
- Use wheel chocks to block the chipper tires so that the chipper doesn't move, shift, or roll during operation.

**ALWAYS KEEP A FIRST AID KIT AND A FIRE EXTINGUISHER WITH CHIPPER**

### LOWER THE INFEED TRAY

- During transportation the infeed tray will be closed and locked using the spring lock pins attached. At the job site, pull the pins in and lower the tray.



- Locking the tray will prevent the tray being jerked closed by the brush being chipped and causing damage and possible injury.

### AIM DISCHARGE CHUTE

- Carlton Chippers are equipped with a rotating discharge chute. To rotate the chute to the desired position
  1. Pull down and unlock the rotation lock pin.
  2. Use the handle on the chute and pull or push the chute in a safe direction to discharge chips.
  3. Release the lock pin making sure it engages in one of the lock grooves on the discharge chute securing the chute in desired position.

ALWAYS MAKE SURE THE DISCHARGE IS POINTED IN A CLEAR DIRECTION FOR DISCHARGE OF CHIPS  
NEVER ROTATE DISCHARGE CHUTE WHILE CHIPPER IS IN OPERATION OR WHILE THE CUTTER DISK IS SPINNING



- There is an adjustable flap on the end of the discharge chute. This flap is adjustable in the vertical direction to help control the height and distance of the chips being discharged. To adjust loosen handle and rotate the flap up or down to desired position.

NEVER ADJUST THIS FLAP WHILE CHIPPER IS IN OPERATION OR WHILE THE CUTTER DISK IS SPINNING



- Stay clear of discharge zone when running chipper. Never allow anyone to stand near or to walk close to the discharge zone, even if being discharged into a bin or truck.
- Airborne debris may cause severe injury. If inspection of chipped material is required, shut down the machine first.
- Discharge spout should not be pointed toward people, buildings, or other personal property that may be injured or damaged. Airborne debris is as dangerous as any powerful projectile.
- Never position, adjust, or move the discharge chute while the chipper or the cutter disk is running



## START ENGINE

- The Key Switch is located on the Kohler engine.
- Key switch has 3 positions
  - Stop, Run and Start
- Start engine at idle speed and allow sufficient time for oil to circulate before proceeding.
- **The cutter disc is directly driven by the engine and will begin to turn when engine is started.**

**DO NOT OPERATE THE ENGINE AT AN ANGLE GREATER THAN 25° OR SEVERE ENGINE DAMAGE WILL OCCUR. PROPER ENGINE OIL LEVEL MUST BE MAINTAINED TO ACHIEVE MAXIMUM ANGLE OF OPERATION OF 25°. (See Engine Owner's Manual for proper oil level.)**



- Test the controls for proper operation, especially the feed control bar. (The engine speed must be high enough for the Auto-Feed® to engage the hydraulics or the Auto-Feed® must be off. Press down the left button and hold for 4 seconds to turn Auto-Feed® off.)
  - Pull feed control bar to the rear of the machine to test forward (pulling) feed wheel motion
  - Push feed control bar to the middle position to test off position (feed wheels should not turn at all)
  - Push feed control bar all the way toward the front of the machine to test the reverse feed wheel motion



**TURN AUTO-FEED PLUS ON**

- The Auto-Feed Plus® monitors the engine RPM and controls the feed system based on this information. The Auto-Feed® is calibrated when installed in the chipper with a high and low RPM setting for the feed wheels to operate. When the engine RPM is low and the Auto-Feed® is on, the hydraulics will not work. If large diameter wood is being chipped and the engine RPM drops below the Auto-Feed® Low setting, the Auto-Feed® will stop the feed wheels. After the engine RPM is high enough to handle the force required to chip this material without causing the engine to lug down, the Auto-Feed® restarts the feed wheels.
- The Auto-Feed Plus® control is calibrated to automatically come on when the chipper is started. If for some reason you need to turn on the Auto-Feed Plus® control, press and hold the right button down for 4 seconds and release.
- Read the Auto-Feed Plus® manual supplied at the end of this chipper manual if programming is required.

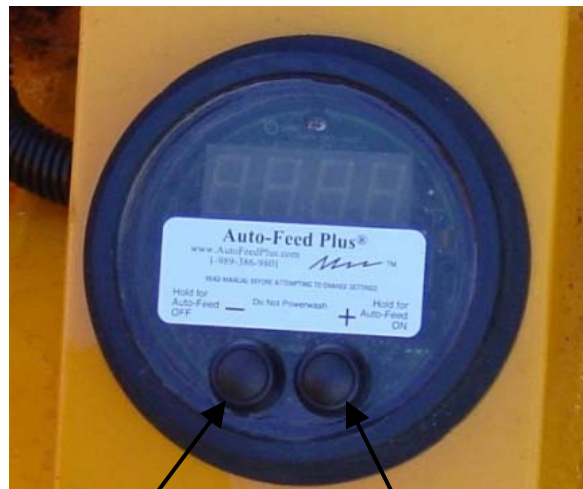

**AUTO-FEED OFF**  
(PRESS AND HOLD FOR 4 SECONDS TO TURN OFF)

**AUTO-FEED ON**  
(PRESS AND HOLD FOR 4 SECONDS TO TURN ON)

### **INCREASE ENGINE SPEED**

- Use the throttle to increase engine speed.
- The engine should always be run at high RPM while material is being chipped. This will help keep the discharge chute from clogging. High engine speed increases the throwing power.



### **PERSONAL SAFETY**

- All personnel must be wearing protective equipment: eye and ear protection; hard hat; short fitted gloves without cuffs; long sleeve shirt; long pants without cuffs; and over the ankle work boots with skid resistant soles.



### **FEED MATERIAL**

- You are now ready to start feeding material into the chipper.
- **Always have at least two operators at the job site.** One to load the trees and brush into the chipper and one to always stand and operate the feed control bar. It is imperative to have someone operate the feed control bar in case of an accident where someone is pulled into the feed wheels.
- Always have the trees and brush cut to size for the chipper before the chipper arrives at the job site.
- It is very dangerous to run a chain saw and the chipper at the same time.





- If a tree gets jammed and has to be trimmed, shut down the chipper.
- Always feed trees and brush walking to the right side of the chipper, material being fed should be to the operators' left side. When the material is being fed into the feed wheels it tends to kick to the left and an operator could be injured if loading the material from the left side.
- Start feeding smaller diameter trees and brush first and work your way up to the full capacity of the chipper, which is 6" diameter material. Feed pieces long enough for the feed wheels to pick up without endangering yourself by reaching into the infeed chute. **No one should ever reach or kick into the infeed chute for any reason when the feed wheels or engine are running.** Feed shorter pieces of brush and limbs on top of longer material. Machine is equipped with a feed compensated flow control that allows the operator to control the flow to the feed wheels. Factory setting is the flow control completely turned clockwise. Counterclockwise will slow feed wheels down.
- Pay close attention to feeding the small diameter material that is long enough, 6' or shorter, to be fed into the feed wheels but doesn't have enough weight to be held down when the wheels first grab onto it. This material could kick straight up and hit the operator causing injury. Hold the material away from the body using both hands and never lean over the material in case the feed wheels cause it to kick up.
- Do not hold onto or try to force the material through the chipper. Once the material has been grabbed by the feed wheels and is being chipped, release it and let the chipper do its job. When the chipper feed wheels are feeding the material, turn away from the material and walk away to get more material.



ALWAYS FEED MATERIAL FROM THE RIGHT SIDE  
AND BUTT END FIRST

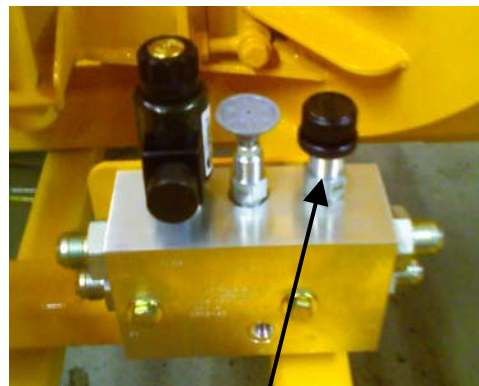

Flow Control

- Keep an eye on the surrounding area and don't allow anyone to come up too close to the chipper or to be in the chip discharge area. Maintain a clear area of at least 100 ft. in every direction around the chipper.
- **Do not lean, reach, or kick past the safety zone when feeding material.**



**NOTE: The cutter disc is directly driven by the engine and will begin to turn when engine is started.**

### SHUT DOWN PROCEDURES

- With engine RPM still high, push the feed control bar to the middle (off) position. Feed wheels should not be turning.



Push the throttle over into the low position so that the engine can slow down then turn the key to the off position.



**CAUTION: Chipper disk will continue to spin even though it is disengaged!**

**CAUTION: Chipper disk will continue to spin even though then engine has turned off!**

- Allow the engine to idle for 5 minutes. This allows the engine to cool.
- When the engine has had time to cool down, you can turn the ignition key to the off position.
- Allow the cutter disk and belt to come to a complete stop, which will take several minutes.
- **Remove the ignition key.**



- The chipper infeed tray must be closed and locked when towing.
- Make sure there is no other obstruction, such as limbs, bark, or leaves, in between the infeed chute and the tray.
- Close and lock the infeed chute. Make sure the spring lock pins are in position and the tray is secured.
- **NEVER STORE OR TRANSPORT ANYTHING INSIDE THE CLOSED INFEED CHUTE!**



SPRING LOCK PINS

- Secure the discharge chute. Pull down the flap and adjustment handle to position the chute over the chipper front. When discharge is in position, release the pin in the closest groove to lock. Make sure the discharge chute is locked in position.
- The flap on the end of the discharge chute needs to be lowered as far as possible so that no debris comes out during travel.



Remove the wheel chocks before moving the chipper.

**⚠ DANGER**

DO NOT PERFORM MAINTENANCE OF ANY KIND ON THIS MACHINE UNLESS:

- ♦ The engine is turned off
- ♦ The ignition key has been removed
- ♦ The positive battery cable has been disconnected
- ♦ The feed control bar is in neutral
- ♦ All machine parts have come to a complete stop – NOTE: The cutter disk takes several minutes to come to a complete stop
- ♦ All machine parts have had sufficient time to cool down
- ♦ The cutter disk lock pin is installed in the disk lock tube
- ♦ No operator is in position at the controls to accidentally start machine
- ♦ At least 2 people are at the site where maintenance is performed

**More accidents occur while performing maintenance than any other time! Use extra caution.**

**Never** perform maintenance with the engine running, not even with the belt(s) disengaged.

**ALWAYS REPLACE GUARDS AND OTHER PROTECTIVE EQUIPMENT BEFORE STARTING CHIPPER AFTER PERFORMING MAINTENANCE.**

## ENGINE

- The air filters, fans and the oil and fuel filters are extremely important in chipper operation. (For all other engine maintenance follow the engine manufacturer's manual.)

### AIR FILTERS – MAIN & SAFETY

- Inspect the main and safety air filters daily.
- Do not tap or hit the main air filter on ground to clean it. Do not wash the main air filter. Follow the engine manual for cleaning the main air filter. Replace the air filter when it cannot be cleaned or after cleaning six times or if damaged.

### NOTICE

Never run the engine without the air filter installed or with a damaged air filter. Replace air filters if there is damage to the pleats, gaskets, or seals. The air filter is used to prevent airborne debris from getting into the engine. If dirt is allowed to get into the engine it will greatly reduce engine life and/or cause damage. Never service the air cleaner with the engine running.



- Do not clean the safety filter. Replace the safety filter if dirty or when the main air filter has been **cleaned** 3 times.
- When cleaning or changing the air filters, place tape over the air inlet hole to reduce the chance of any dirt getting inside the engine. Use a clean dry cloth to wipe down the inside of the air cleaner housing and cover.
- Check the general condition of the air cleaner housing and components. Make sure there are no dents, cracks, or other damage to these parts that could allow unfiltered air to enter the engine.



#### OIL & OIL FILTER

- Change engine oil and filter after the first 50 hours of operation and then every 100 hours thereafter. Follow the engine manufacturer owner's manual for changing the oil & filter. Only use engine manufacturer recommended oil filter. Some engine manufacturers require special break-in oil to be run for a certain period of time. Refer to engine manual supplied with your chipper.
- Check fuel level daily and replenish as necessary. Carlton chipper fuel tanks are equipped with lockable cap covers.



#### FUEL FILTER

Replace the fuel filter every 500 hours of operation or 6 months. Follow the engine owner's manual on how to remove the filter. Make sure to clean the area around the fuel filter before removing any parts; do not take a chance on contaminating the fuel line. Do not leave spilled fuel on the machine; spilled fuel on hot engine parts can cause fires.



### FEED CONTROL BAR

- Before starting to chip any wood, always test the feed control bar. Make sure the reverse, stop, and forward feed positions work properly.
- Contact Carlton or an authorized dealer immediately if the control bar doesn't work properly in any of the three positions.
- **ALWAYS VERIFY CORRECT FUNCTION OF THE FEED CONTROL BAR BEFORE BEGINNING TO CHIP MATERIAL**
- **NO ONE SHOULD EVER REACH, LEAN, OR KICK INTO THE FEED INTAKE CHUTE WHEN THE MACHINE OR THE ENGINE IS RUNNING**



Apply a light coating of oil to the feed control linkage **weekly**.



FEED CONTROL LINKAGE

## HITCH

- Make sure the bolts on the chipper hitch are tightened. Also, make sure the hitch bolts on the tow vehicle are tightened properly.
- Check the bolts and nuts for wear. If bolt or nut threads are chipped or worn down, or if the bolts and nuts won't stay tight after tightening them, the bolts and nuts need to be replaced. Check the bolt holes for wear also. If the holes are stretched or distorted, the hitch will need to be replaced.
- The 6" chipper is equipped with a 2" hitch.



## LIGHTS WIRING

- Check lighting wire connections for damage, and loose or broken wires.
- Make sure the lights are working properly at all times when towing.

**See the Machine Wiring section of this manual for wiring diagram.**





### JACK STAND – FRONT

- Check the lock pins to make sure they are fitting properly and in good shape. Replace any pins that are worn, bent or damaged in any way.
- Check general condition of the jack stand. Make sure the holes are not worn or elongated. Check the bottom of the jack to make sure it will sit level on level ground. Replace the jack stand if it is warped, has unusual wear, or if it won't hold position when supporting the chipper.
- Grease the jack stand as necessary.

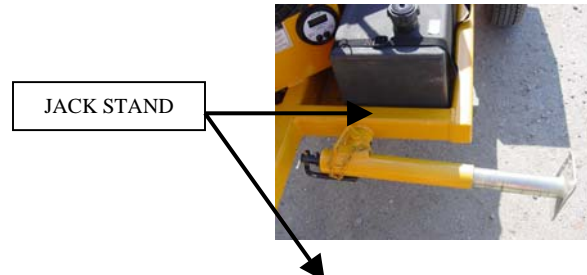

### TIRES AND AXLES

- Check air pressure in tires daily. Inflate tires as necessary. Keep tire air pressure adjusted based on the temperature and the load.
- When towing, make sure the chipper is sitting as close to level as possible to ensure proper tire wear and axle alignment.
- Check lug nuts for proper tightness. Tighten when necessary. Replace lug nuts if the threads are worn, chipped, or missing.
- Check tire rims for damage that could cause improper air pressure. If rims are damaged beyond repair, replace.
- See Dexter information for E-Z Lube® or Nev-R-Lube® Axles supplied in this manual. Remember to inspect axles regularly.
- Check and replace dust caps as needed.



### FRAME

Periodically check the chipper frame and other permanent parts for cracks, bends, failed welds, or other damage that needs repair. Repair as necessary or contact an authorized dealer.



- All of Carlton’s machines are built to be rugged performers. Our design goals are sturdiness, simplicity and reliability.
- A regularly scheduled maintenance program will pay big dividends in machine life, performance, and avoided downtime.
- Check grease fittings regularly and replace any that are clogged or missing.
- Below you will find a Lubrication Schedule that will give you the recommended frequency for lubrication.
- Next you will find specific locations of the grease points.
- Use a hand operated grease gun.

Lubrication Schedule

- Use **Texaco® Starplex II** grease.
- **Always clean tip of grease gun fitting and grease fitting on machine before attaching hose to prevent dirt from being forced into machine parts.**

CARLTON MODEL 660	8 HRS	30-40 HRS	100 HRS	300 HRS	500 HRS	SPECIAL COMMENTS
FEED WHEELS ROLLER BEARINGS (2)						ONE PUMP OF GREASE DAILY ON EACH BEARING
DISCHARGE CHUTE						
CUTTER DISK BEARINGS (2)						PURGE BEARINGS, DAILY, UNTIL NEW GREASE IS SEEN
WHEEL AXLE BEARING (2)						SEE DEXTER INFORMATION FOR E-2 LUBE OR NEV-R-LUBE AXLES (ENCLOSED IN MANUAL)
SWIVEL PLATES						EVERY 3 MONTHS GREASE THE SWIVEL PLATES
ENGINE REFER TO ENGINE MANUFACTURERS MANUAL FOR PROPER ENGINE SERVICING						

660-1 (AHF/01/09)

**CHIPPER – LEFT SIDE**





**CHIPPER – RIGHT SIDE**



**DO NOT PERFORM ANY INSPECTION OR SERVICE ON THE CHIPPER WITHOUT MAKING SURE: THE CUTTER DISK IS DISENGAGED AND HAS COME TO A COMPLETE STOP; THE CUTTER DISK LOCK PIN IS INSTALLED; THE ENGINE HAS BEEN TURNED OFF, THE IGNITION KEY HAS BEEN REMOVED AND THE BATTERY CABLE HAS BEEN DISCONNECTED; THE FEED WHEELS HAVE BEEN RAISED; AND THERE ARE AT LEAST TWO OPERATORS AT THE SITE.**

**FOLLOW PROPER MAINTENANCE PROCEDURES IN SERVICE SECTIONS TO REPAIR OR REPLACE PARTS OR CONTACT YOUR DEALER.**

COMPLAINT	CAUSE	CORRECTION
Discharged chips are not correct size: too large or too fine	<ul style="list-style-type: none"> <li>• Knives have lost their edge</li> <li>• Knife anvil worn</li> <li>• Check for wear in the throat/base area (non-cutting areas)</li> <li>• Knife angle is not correct</li> <li>• Material being chipped is very small, dry or rotting</li> </ul>	<ul style="list-style-type: none"> <li>• DO NOT operate chipper with dull knives or with mismatched knives (see Servicing Cutter System section)</li> <li>• Rotate, repair, or replace (see Servicing Cutter System section)</li> <li>• Outer, non-cutting edges that are exposed to chipper knives must be built up with weld to maintain surface to original integrity</li> <li>• Make sure knives are ground at correct angle (see Servicing Cutter System section)</li> <li>• This type of material does not produce good chip quality</li> </ul>
Cutter disk knife hits anvil	<ul style="list-style-type: none"> <li>• Anvil to knife clearance is not correct</li> <li>• Check the chipper bearing retainer cap for tightness</li> </ul>	<ul style="list-style-type: none"> <li>• See Servicing Cutter System section for adjustment</li> <li>• Retighten bolts or setscrews as tight as possible</li> </ul>
Discharge chute clogs or chips are not discharging properly	<ul style="list-style-type: none"> <li>• Lugging engine on large material</li> <li>• Obstruction in discharge chute</li> <li>• Chipping rotting material that has little substance can also plug the discharge chute</li> </ul>	<ul style="list-style-type: none"> <li>• Keep engine speed up and use feed control bar to reverse material if engine lugs down, check Auto-Feed Plus setting and adjust (see Auto-Feed Plus Manual)</li> <li>• Any object that protrudes inside the chute may cause clogging; replace discharge chute, if necessary</li> <li>• Use care when running this type of material; “flush” the discharge chute using other material with more substance</li> </ul>



COMPLAINT	CAUSE	CORRECTION
Auto-Feed not working properly or at all	<ul style="list-style-type: none"> <li>• Faulty or broken wiring</li> <li>• Settings not correct</li> </ul>	<ul style="list-style-type: none"> <li>• Repair or replace wires – wiring diagram enclosed in this manual</li> <li>• Reset following Auto-Feed manual instructions enclosed in this manual</li> </ul>
Chipper bearings are overheating	<ul style="list-style-type: none"> <li>• Bearings are dry</li> <li>• Check the chipper bearing retainer cap for tightness</li> <li>• Bearings worn out</li> <li>• Setscrews on sheave side bearing not tight</li> </ul>	<ul style="list-style-type: none"> <li>• Grease bearings daily using Texaco® Starplex II grease</li> <li>• Retighten bolts or setscrews as tight as possible</li> <li>• Replace</li> <li>• Tighten</li> </ul>
Feeding material causes feed wheel to slow down or stop	<ul style="list-style-type: none"> <li>• Dull knives</li> <li>• Relief valve is worn or dirty</li> <li>• Hydraulic pump has excessive wear</li> <li>• Feed wheel motor not working properly</li> <li>• Feed wheel springs too tight</li> </ul>	<ul style="list-style-type: none"> <li>• Replace knives (see Servicing Cutter System section)</li> <li>• Clean or replace; reset pressure</li> <li>• Replace</li> <li>• Check &amp; replace</li> <li>• Adjust</li> </ul>
Feed wheel doesn't turn or turn too slow to feed material	<ul style="list-style-type: none"> <li>• Feed wheel motor not working properly</li> <li>• Relief valve opens too easily or stuck open</li> <li>• Feed wheel valve (control valve) worn &amp; leaking internally</li> <li>• Feed wheel relief pressure off</li> <li>• One or more hoses may be crimped or leaking</li> <li>• Hydraulic oil level low</li> <li>• Pump has excessive wear</li> <li>• Feed wheel binding</li> <li>• Control lever improperly shifting valve</li> <li>• Worn or dirty flow divider</li> </ul>	<ul style="list-style-type: none"> <li>• Reverse hoses at flow divider - if same motor still doesn't turn, motor is probably bad; if other motor is now the one not turning, the flow divider is probably bad. Repair or replace</li> <li>• Valve needs to be cleaned or replaced; reset pressure</li> <li>• Check &amp; Replace</li> <li>• Reset pressure to 2500 PSI</li> <li>• Replace (see Servicing Hydraulics section)</li> <li>• Keep oil level about 7/8 full</li> <li>• Replace pump</li> <li>• Check bearings, lubricate properly</li> <li>• Readjust; valve must open completely</li> <li>• Clean or replace</li> </ul>

COMPLAINT	CAUSE	CORRECTION
Engine won't turn over	<ul style="list-style-type: none"> <li>• Battery is dead</li> <li>• Cutter disk hood safety switch is not in position</li> </ul>	<ul style="list-style-type: none"> <li>• Recharge or replace battery</li> <li>• Cutter disk hood lock pin and safety switch must be in position for the engine to start</li> </ul>
Hydraulic oil overheating and causing chipper to operate slower than normal	<ul style="list-style-type: none"> <li>• Pump has excessive wear or not working properly</li> <li>• Hose crimped or leaking</li> <li>• Relief valve opens too easily or stuck open</li> <li>• Feed wheels binding</li> <li>• Hydraulic tank oil level is too low, hydraulic oil is contaminated, or hydraulic filter is dirty</li> <li>• Hydraulic oil viscosity is wrong for atmospheric temperature</li> </ul>	<ul style="list-style-type: none"> <li>• Check &amp; replace pump, if necessary</li> <li>• Replace (see Servicing Hydraulics section)</li> <li>• Valve needs to be cleaned or replaced; reset pressure</li> <li>• Check bearings, lubricate properly</li> <li>• Keep oil tank about 7/8 full; follow proper maintenance schedule and change oil and filter as suggested (see Servicing Hydraulics section)</li> <li>• Contact JP Carlton or local dealer for recommended oil type for the situation</li> </ul>
Hydraulic pump making loud noise or a lot of noise (pump is cavitated)	<ul style="list-style-type: none"> <li>• Hydraulic oil viscosity is wrong for atmospheric temperature</li> <li>• Oil operating temperature too low</li> <li>• Pump has excessive wear</li> </ul>	<ul style="list-style-type: none"> <li>• Contact JP Carlton or local dealer for recommended oil type for the situation</li> <li>• Allow system to warm up</li> <li>• Replace pump</li> </ul>

Any other problems contact your local dealer or J. P. Carlton Co.

**ONLY USE QUALIFIED PERSONNEL TO WORK ON HYDRAULIC SYSTEMS FOR REPAIRS OR REPLACEMENT OF PARTS!!**

**⚠ DANGER**

DO NOT PERFORM MAINTENANCE OF ANY KIND ON THIS MACHINE UNLESS:

- ◆ The engine is turned off
- ◆ The ignition key has been removed
- ◆ The positive battery cable has been disconnected
- ◆ The feed control bar is in neutral
- ◆ All machine parts have come to a complete stop – NOTE: The cutter disk takes several minutes to come to a complete stop
- ◆ All machine parts have had sufficient time to cool down
- ◆ The cutter disk lock pin is installed in the disk lock tube
- ◆ No operator is in position at the controls to accidentally start machine
- ◆ At least 2 people are at the site where maintenance is performed

**More accidents occur while performing maintenance than any other time! Use extra caution.**

**Never** perform maintenance with the engine running, not even with the belt(s) disengaged.

**ALWAYS REPLACE GUARDS AND OTHER PROTECTIVE EQUIPMENT BEFORE STARTING CHIPPER AFTER PERFORMING MAINTENANCE.**

**WARNING:**

- **RELEASE HYDRAULIC PRESSURE BEFORE PERFORMING ANY SERVICE TO HYDRAULIC LINES OR OTHER COMPONENTS.**
- **FLUID UNDER PRESSURE CAN PENETRATE THE SKIN AND CAUSE SEVERE INJURY. SEEK IMMEDIATE MEDICAL ATTENTION IF SKIN IS PENETRATED. CHECK HOSES AND FITTINGS USING A BOARD OR CARDBOARD; DO NOT USE HAND OR FINGER. ALWAYS WEAR EYE PROTECTION.**

**HYDRAULIC OIL & FILTER**

- This Carlton chipper has an in-tank hydraulic filter . Check hydraulic oil daily, before and during use. Use AW-32 hydraulic oil same as supplied by the manufacturer.



**HYDRAULICS**

Check hydraulic oil level daily. This Carlton chipper is equipped with a translucent hydraulic tank. Keep tank 7/8 full at all times

- On a new chipper, change the hydraulic oil filter when the chipper has been operating for 10 hours. Replace with the same type of in-tank filter element supplied originally, available through Carlton or Carlton dealers. From this point on, change the filter every 200 hours of operation.
- Change hydraulic oil every 500 hours of operation or at least once a year depending on use. Flush the hydraulic tank when changing the hydraulic oil. Replace oil if it has a burnt odor or if it is contaminated. Replace oil if the chipper has been stored for a long period of time (all winter).  
Drain the hydraulic tank and dispose of used oil according to state regulations.



**HOSES AND FITTINGS**

- Inspect hoses and fittings for leaks, tightness, wear, or damage. Replace any hoses and fittings that need replacing.
- **FLUID UNDER PRESSURE CAN PENETRATE THE SKIN AND CAUSE SEVERE INJURY. CHECK HOSES AND FITTINGS USING A BOARD OR CARDBOARD; DO NOT USE HAND OR FINGER. SEEK IMMEDIATE MEDICAL ATTENTION IF SKIN IS PENETRATED. ALWAYS WEAR EYE PROTECTION.**
- The overall pressure setting is 2500 PSI, set at the factory. Do not adjust the pressure setting. If you feel the pressure needs adjusting, contact JP Carlton or you local Carlton dealer.



**ONLY USE QUALIFIED PERSONNEL TO WORK ON HYDRAULIC SYSTEMS FOR REPAIRS OR REPLACEMENT OF PARTS!!**

**CUTTER SYSTEM**

**⚠ DANGER**

DO NOT PERFORM MAINTENANCE OF ANY KIND ON THIS MACHINE UNLESS:

- ◆ The engine is turned off
- ◆ The ignition key has been removed
- ◆ The positive battery cable has been disconnected
- ◆ The feed control bar is in neutral
- ◆ All machine parts have come to a complete stop – NOTE: The cutter disk takes several minutes to come to a complete stop
- ◆ All machine parts have had sufficient time to cool down
- ◆ The cutter disk lock pin is installed in the disk lock tube
- ◆ No operator is in position at the controls to accidentally start machine
- ◆ At least 2 people are at the site where maintenance is performed

**More accidents occur while performing maintenance than any other time! Use extra caution.**

**Never** perform maintenance with the engine running, not even with the belt(s) disengaged.

**CUTTER WHEEL IS ENGAGED WHEN ENGINE IS RUNNING.**

**ALWAYS REPLACE GUARDS AND OTHER PROTECTIVE EQUIPMENT BEFORE STARTING CHIPPER AFTER PERFORMING MAINTENANCE.**

**INSPECT/CHANGE KNIVES**

- Cutter disk knives need to be kept sharp and free of chips to keep the chipper running smoothly. Visually inspect knives daily for dull edges, chips, and other damage. Dull or chipped knives do not cut well adding stress to the engine and requiring more power to cut through the wood. This can cause heat to build up and cause knife failure.
- Check the knives if the wood chips are too large, if the material will not feed properly, or if the engine lugs down.
- **Always wear leather gloves when handling knives. Edges are extremely sharp and could cause severe injury.**



KNIFE EDGE



**CUTTER SYSTEM**

**DANGER:** Make sure the ignition key has been removed and machine can't be started before servicing any part of the chipper.

**DANGER:** Do not open the cutter disk hood until the cutter disk has come to a complete stop. Do not perform service on the cutter disk or knives without installing the disk lock pin.

- Remove the padlock and lock pin from the cutter disk hood and open.
- The cutter disk lock pin will have to be removed to rotate the cutter disk and inspect the knives. Use extra care when rotating the cutter disk to prevent injury. **Always wear leather gloves when performing any service on the cutter disk system.**

**DANGER – KNIVES ARE EXTREMELY SHARP**

- Inspect knives. If knives are still in good shape, proceed with other inspections or maintenance. To change knives, follow these procedures.
- Install the cutter disk lock pin. Rotate the cutter disk slowly to line up holes and insert the pin.
- Remove the three bolts and nuts holding each knife in place on the cutter disk. There are two knives 180° from each other on the wheel.
- Inspect the bolts and nuts carefully for worn, chipped, or stripped threads.
- Do not remove and replace knife bolts and nuts more than 3 times before replacing with new bolts and nuts.
- **Knife bolts are of a particular design and nuts are security lock nuts. DO NOT USE ANY OTHER STYLE OF BOLTS AND NUTS. You must purchase these bolts and nuts from Carlton or an authorized dealer.**



CUTTER DISK LOCK PIN  
IN LOCKED POSITION

**CUTTER SYSTEM**

- After knives have been removed, clean the pocket to remove any debris that may keep the knife from seating properly.

**DANGER – KNIVES ARE EXTREMELY SHARP**

- Inspect both edges of knives; **wear leather gloves while handling knives.** If knives still have one good edge, rotate each knife and reassemble. Both knives should be the same distance from center of hole to outside edge to properly adjust anvil clearance and balance cutter disk.
- Inspect knife bolt holes for cracks or distortion. Check knife for distortion using a straight edge and a light, replace the knife if distorted. Replace knives if any problems are found.
- If both edges are worn or chipped, have knives ground to sharpen.
- **Never** use knives that are below 1 13/16" from center of hole to outside edge of knife. Keep sets of knives together that are ground to the same distance from center of hole to outside edge. This will keep the cutter disk balanced reducing chipper vibration and improving cutting. There are two knives 180° from each other on the same side of the wheel.
- **ONLY** have knives sharpened by an authorized dealer using the proper equipment.
- **Improper sharpening may affect knives hardness resulting in knife failure.**
- If knives are too narrow to grind, replace with a complete set of new knives.
- Knives are hardened steel made to Carlton's specifications. Use only Carlton chipper knives as replacements.

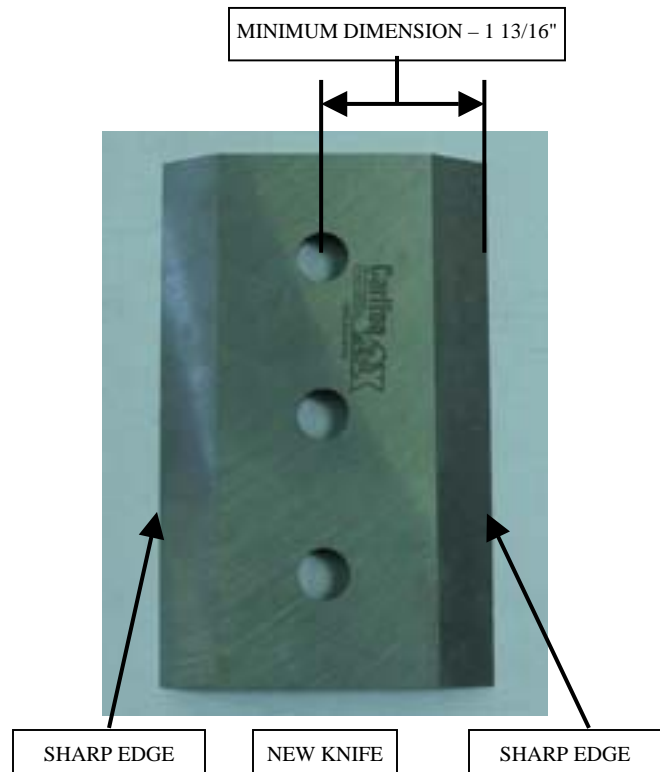

## **CUTTER SYSTEM**

- Reassemble knives in the pocket making sure they seat flat.
- Tighten knife bolts and torque the nuts to 90 ft. lbs.
- Do not over tighten knife bolts. Torque only to the recommended amount. Knives that are overly tight can crack or bow around the hole. This could cause chipped material to pack between the knife and cutter disk causing knife failure. Check knife for distortion using a straight edge and a light, replace the knife if distorted.



### **CHECK/ADJUST CLEARANCE**

#### **ALWAYS CHECK AND SET KNIFE TO ANVIL CLEARANCE AFTER REMOVING AND REPLACING KNIVES OR ANVIL.**

- Disconnect feed wheel springs on both sides of the chipper before raising the upper feed wheel.
- Raise the upper feed wheel by hand, attached as shown at right. **THE CHIPPER MUST BE SECURELY ATTACHED TO TOW VEHICLE BEFORE RAISING THE UPPER FEED WHEEL.**
- Lift until the upper feed wheel has been raised high enough to insert the yoke lock pin.
- **The yoke lock pin must be inserted in the yoke lock hole after the upper feed wheel has been raised.**





**CUTTER SYSTEM**

- Inspect the anvil working edge for wear or damage before you check the clearance. If the anvil needs to be changed to a new work surface or to be replaced, follow the instructions in Anvil Replacement later in this section. The anvil has four working edges that can be used before replacing.
- Check the clearance between the knives and the anvil. The clearance for the knife to anvil should be between .045" and .065" (1.14 – 1.65 mm). Use a feeler gage that measures within that range. The gage should fit easily between the knife and the anvil without force and without too much free space on either side. Check clearance at the top and bottom of each knife assembly.



ANVIL WORKING EDGE



CHECKING KNIFE/ANVIL CLEARANCE

FEELER  
GAGE



- One person will need to be in the infeed chute area to check the clearance between the anvil and the knives. While another person is outside to make the adjustments and to turn the cutter disk. The disk will have to be rotated fully to check both knife settings at top and bottom of each knife.
- **This is one time that the cutter disk lock pin will not be in position so extreme care needs to be taken for safety. Before allowing anyone to be in the infeed chute, make sure there is no obstruction or binding in the cutter disk by turning it by hand from the outside first. If the cutter disk does not turn freely, find and remove the obstruction and then proceed.**



ROTATE CUTTER DISK TO CHECK FOR BINDING

## CUTTER SYSTEM

- If clearance needs to be adjusted, loosen the anvil bolts; just loose enough to be able to move the anvil with the adjuster bolts.
- Loosen the nuts on the adjustment bolts that are on the far side of the plate (as shown). There are two adjustment bolts.
- Using the nuts on the inside of the plate, turn the nuts up toward the machine to move the anvil closer to the knife. This will shorten the clearance if it was too wide. Make slight adjustments on each bolt as the clearance is being checked.
- Or, you will need to loosen the nuts on the inside of the plate and turn the outside nuts down if the clearance is too narrow for the feeler gage to go in easily. This will move the anvil farther away from the knife.
- After the clearance has been set, tighten the anvil bolts (1/2"-13, Grade 8) and torque to 90 ft. lbs.
- Retighten the nuts on the adjustment bolts that were loosened earlier.
- Recheck the anvil/knife clearance to make sure nothing changed when tightening the bolts.
- Checking and setting the clearance by the knife that is the closest to the anvil will be the best place to start.
- Both knives must be checked and clearance should be .045" - .065" (1.14 – 1.65 mm) on each knife at top and bottom.



**CUTTER SYSTEM**

- After clearance has been set and all bolts and nuts have been tightened properly, remove the yoke lock pin and put it back in its holder.



REMOVE YOKE LOCK PIN AND RETURN TO HOLDER

- Reconnect the upper feed wheel springs on both sides of the chipper.

- **ALWAYS REMEMBER TO CLOSE THE CUTTER DISK HOOD AFTER SERVICING CUTTER DISK.**
- **INSTALL THE HOOD LOCK PIN, SAFETY CLIP, AND PADLOCK.**
- Check condition of cutter disk hood. Make sure the hinges are not damaged and that the hood closes completely with no gaps or openings; check both sides. If there are any problems go to Servicing Cutter Disk Hood later in this section.



NO GAPS OR OPENINGS

**CUTTER SYSTEM**

**SHARPEN KNIVES**

- Have knives ground by a qualified grinder.
- Grind knives at 29° to 31°.
- Before and after grinding the knife-edge, check the width of the knife from the center of the hole to the sharp edge of the knife. Never use a knife with this measurement below 1 13/16".

- **Three factors for a good cutting system are:**

1. **Never use a knife with the distance from the cutting edge to the center of the bolt hole less than 1 13/16".**
2. **Always use knives in sets of two with the dimension from the cutting edge to the center of the bolt hole as close as possible to each other.**
3. **Never use a knife if the back edge is inside the knife pocket edge.**

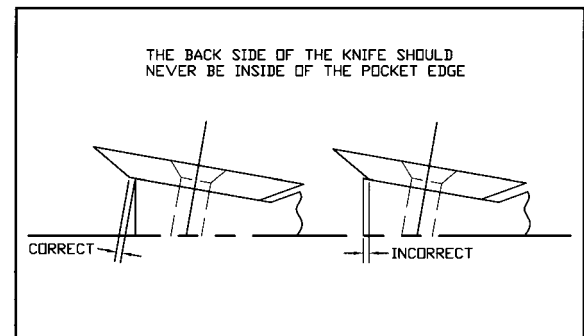
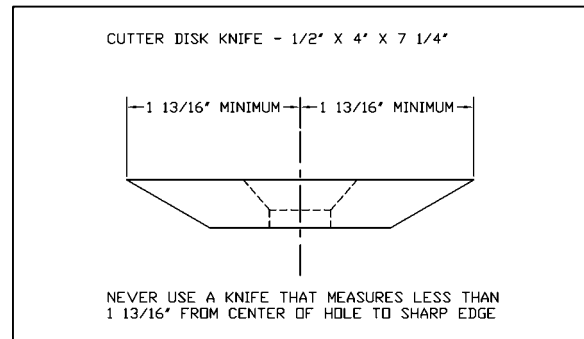

**KNIVES**

PART NO	DESCRIPTION	QTY
0900114	Knife – 1/2" x 4" x 7 1/4"	2
0900124Z	1/2" Knife Bolt – Special Design – Purchase from JP Carlton or Dealer	6
0900126	1/2" Security Lock Nuts – Purchase from JP Carlton or Dealer	6



**CUTTER SYSTEM**

**DANGER:**

- **TURN ENGINE OFF**
- **REMOVE IGNITION KEY**
- **PUT FEED CONTROL BAR IN NEUTRAL**
- **ALLOW CUTTER DISK TO COME TO A COMPLETE STOP**
- **ALLOW ALL PARTS TO COOL COMPLETELY**
- **INSTALL CUTTER DISK LOCK PIN**



**ANVIL REPLACEMENT**

- **THE UPPER FEED WHEEL MUST BE RAISED AND HAVE YOKE LOCK PIN IN POSITION BEFORE WORKING BETWEEN FEED WHEELS.** (See information earlier in this section for raising the upper feed wheel)
- Check the anvil for wear when knives have been changed and clearance is being set. The anvil has four working edges that can be used before having to be replaced. Rotate the anvil to a new working edge unless all edges are worn and the anvil needs replacing.
- **Do not** grind the anvil to get more life. There is only a certain amount of adjustment available for clearance and if the anvil is ground you will lose that adjustment capability.
- The anvil is hardened steel made to Carlton's specifications. Use only Carlton anvils as replacements or damage may occur. Purchase the new anvil from Carlton or an authorized dealer.

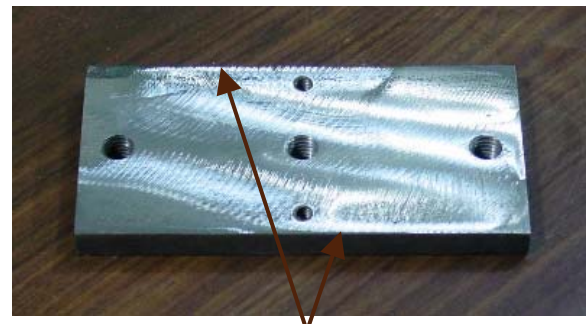

THE ANVIL HAS FOUR WORKING EDGES. TWO OF THESE EDGES ARE SHOWN ABOVE. FLIP THE ANVIL OVER FOR THE OTHER TWO EDGES.

**CUTTER SYSTEM**

- To rotate to a new edge or to replace the anvil, remove the anvil bolts and adjuster bolts. There are two anvil bolts, two with adjuster bolts attached.
- First, remove the nut on the outside of each adjuster bolt and loosen the inside nut. Then remove the anvil bolts.



- Keep all hardware together for easier replacement.
- Replace any worn or damaged bolts, nuts or other hardware at this time.
- Use the handle on the anvil to rotate the anvil 90° and pull it through the slot.

Turn the anvil to a good working edge.



REMOVE ANVIL BOLTS & WASHERS



**CUTTER SYSTEM**

- Replace with a new anvil if all working edges are worn or damaged. **Do not** grind the anvil to get more life. There is only a certain amount of adjustment available for clearance and if the anvil is ground you will lose that adjustment capability.
- Place anvil back in machine
- Make sure the hardware is replaced in the correct order. The lock washer will go on first, closest to the head of the bolt, and then a flat washer for the top and bottom bolts. Put the adjuster eyebolt on last for the top and bottom bolts.
- Hold the anvil in place while putting in the bolts with the adjuster bolts. The adjuster bolts must be inserted through the slot provided to make clearance adjustments. A flat washer goes between the nut on the adjuster bolt and the plate on both sides.

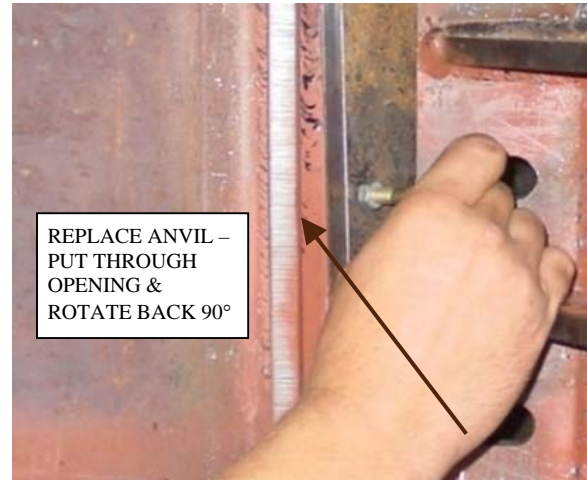



**CUTTER SYSTEM**

- Tighten the anvil bolts loosely. Put a flat washer and a nut back on the outside of each adjuster bolt. Do not tighten the nut until clearance has been set.
- **ALWAYS CHECK & SET KNIFE TO ANVIL CLEARANCE AFTER REMOVING AND REPLACING KNIVES OR ANVIL.**
- Go back to the CHECK/ADJUST CLEARANCE information earlier in this section.
- **THE UPPER FEED WHEEL MUST BE RAISED AND HAVE YOKE LOCK PIN IN POSITION BEFORE WORKING BETWEEN FEED WHEELS.**
- After the clearance has been set, tighten the anvil bolts (1/2"-13, Grade 8) and torque to 90 ft. lbs.
- Retighten the nuts on the adjustment bolts.
- Recheck the anvil/knife clearance to make sure nothing changed when tightening the bolts.
- Both knives must be checked and clearance should be .045" - .065" (1.14 – 1.65 mm) on each knife at top and bottom.
- **ALWAYS REMEMBER TO CLOSE THE CUTTER DISK HOOD AFTER SERVICING CUTTER DISK.**
- **INSTALL THE HOOD LOCK PIN, SAFETY CLIP, AND PADLOCK.**
- Check condition of cutter disk hood. Make sure the hinges are not damaged and that the hood closes completely with no gaps or openings; check both sides. If there are any problems go to Servicing Cutter Disk Hood later in this section.





### SERVICING CUTTER DISK HOOD

- Inspect cutter disk hood for fit and damage daily. Check for cracks around welds.
- Check hood hinges making sure hood closes completely with no gaps or openings; check both sides.
- Hood lock pin must go through locking plates easily and completely allowing room for padlock. Check pin for distortion and cracks.
- The safety clip must be attached and working properly to ensure the chipper cannot be started if it is not in place.
- If any problems are discovered, contact Carlton or your local dealer for repair or replacement.



**THE CUTTER DISK HOOD IS ONE OF THE MOST IMPORTANT PIECES OF SAFETY EQUIPMENT ON THIS CHIPPER. MAKE SURE IT IS KEPT IN GOOD WORKING CONDITION.**

### CUTTER DISK BEARINGS

- Check cutter disk bearing bolts **weekly** for tightness. Replace any bolts that have worn, chipped or missing threads.
- If bolts are loose and need tightening, use LocTite® 262 (Red) and torque 95ft/lbs.



**BELTS AND SHEAVES**

**⚠ DANGER**

DO NOT PERFORM MAINTENANCE OF ANY KIND ON THIS MACHINE UNLESS:

- ◆ The engine is turned off
- ◆ The ignition key has been removed
- ◆ The positive battery cable has been disconnected
- ◆ The feed control bar is in neutral
- ◆ All machine parts have come to a complete stop – NOTE: The cutter disk takes several minutes to come to a complete stop
- ◆ All machine parts have had sufficient time to cool down
- ◆ The cutter disk lock pin is installed in the disk lock tube
- ◆ No operator is in position at the controls to accidentally start machine
- ◆ At least 2 people are at the site where maintenance is performed

**More accidents occur while performing maintenance than any other time! Use extra caution.**

- **Never** perform maintenance with the engine running, not even with the belt(s) disengaged.
- **CUTTER WHEEL IS ENGAGED WHEN ENGINE IS RUNNING.**

ALWAYS REPLACE GUARDS AND OTHER PROTECTIVE EQUIPMENT BEFORE STARTING CHIPPER AFTER PERFORMING MAINTENANCE.

**BELT TENSION**

**CHECK BELT TENSION**

- New belts will stretch and become loose as machine runs. Check belt tension often when belt is new.
- Belt should deflect 1/2" when a force of 12-14 ft. lb. is applied to new belt or 10-12 ft. lb. to used belt. Check belt tension using slot on belt guard.

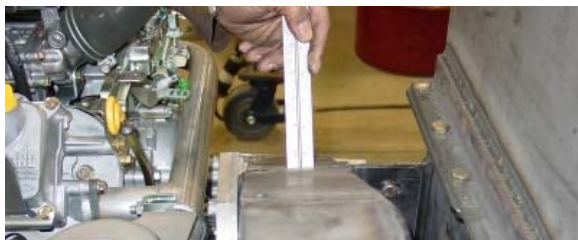

**⚠ DANGER**

**NEVER reach into this area with hands or other objects severe injury, including amputation, could occur.**

**NEVER attempt to service belts or other machine parts until all machine parts have come to a complete stop. ALWAYS REMOVE KEY BEFORE SERVICING MACHINE.**

0700302

**BELTS AND SHEAVES**

- **ENGINE MUST BE OFF AND IGNITION KEY REMOVED BEFORE CHECKING BELT TENSION.**
  - **ALL PARTS MUST BE COMPLETELY STOPPED.**
  - **THE CUTTER DISK LOCK PIN MUST BE INSTALLED IN THE DISK LOCK TUBE.**
  - **CUTTER WHEEL IS ENGAGED WHEN ENGINE IS RUNNING.**
- 
- Insert a screwdriver or metal bar (a metal ruler would be good) through the slot to check belt tension.
  - Make a mark on the screwdriver or metal when it touches the belts without any force applied and then apply force as specified and make another mark.
  - Measure the distance between the two marks. If the measurement is more than 1/2", the belt tension needs to be adjusted. If the measurement is much less than 1/2", the belt tension is too tight.
  - **Do not** over tighten the engine belt. Overly tight belts will cause damage to the engine and cutter disk bearings.

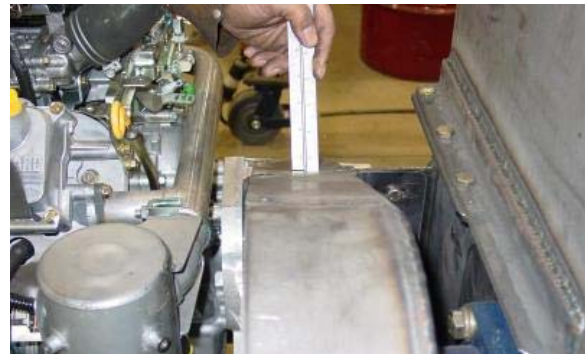

**BELTS AND SHEAVES**

**ADJUST BELT TENSION**

- If belt tension needs to be adjusted, the belt is always engaged.
- To apply more belt tension, loosen the jam nut and engine mounting bolts slightly and turn the adjuster bolt clockwise to move the engine away from the cutter wheel shaft. Turn only one rotation at a time and then recheck the belt tension.
- If belt tension still needs adjusting, repeat the adjustment procedure and tension check procedure until tension is correct.

**Do not** over tighten the engine belt. Overly tight belts will cause damage to the engine and cutter disk bearings.

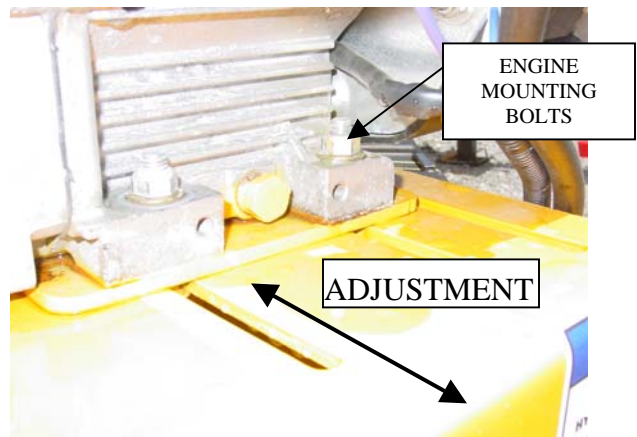



**BELTS AND SHEAVES**

- If belt tension is too tight, do all steps previously mentioned but turn the adjuster bolt counter-clockwise to move the engine towards the cutter wheel shaft.
- Normally a slight adjustment is all that's necessary to adjust belt tension. If you find you have to make several adjustments to get the proper tension, the belt may be worn and need to be replaced. To replace belt, go to REPLACING ENGINE BELT section.
- When the belt tension is adjusted, re-tighten all hardware to keep the engine in-place.



## **BELTS AND SHEAVES**

### **CHECK BELT GUARD**

- Check and retighten bolts daily.
- Check condition of bolt and nut threads when belt guards are removed or if a bolt won't tighten or won't stay tightened.
- Replace any bolts or nuts that are worn or damaged. Replace bolts or nuts with stripped threads.
- **ALWAYS REMEMBER TO REPLACE BELT GUARD COVER BEFORE STARTING MACHINE. ROTATING BELTS AND SHEAVES ARE DANGEROUS AND COULD SEVERELY INJURE SOMEONE.**



### **REPLACING ENGINE BELT**

- **REMEMBER THAT CUTTER WHEEL IS ENGAGED WHEN ENGINE IS RUNNING.**
  - **ENGINE MUST BE OFF AND IGNITION KEY REMOVED BEFORE CHECKING BELT TENSION.**
  - **ALL PARTS MUST BE COMPLETELY STOPPED.**
  - **THE CUTTER DISK LOCK PIN MUST BE INSTALLED IN THE DISK LOCK TUBE.**
- 
- Replace belt when it is worn or regularly needs adjustment.
  - If equipped with more than one belt, replace belts as a complete set. Old or worn belts will not tension the same as new belts and will slip.
  - Remove belt guard bolts and remove belt guard cover.



**BELTS AND SHEAVES**

- Loosen the bolts on the engine and slide the engine towards the cutter wheel shaft so that the belt are loose.
- Remove pump drive. **Only remove the bolts at 12 o'clock and 6 o'clock.** Remove the pump plate with the pump still attached, not necessary to remove and cap hoses.
- When you pull the pump off, the pump coupler and a rubber insert will come off with it. Take note of the insert and do not lose it.
- Loosen beehive to remove belts.
- Remove old belt and install new belt.
- Never pry new belts onto the sheave!

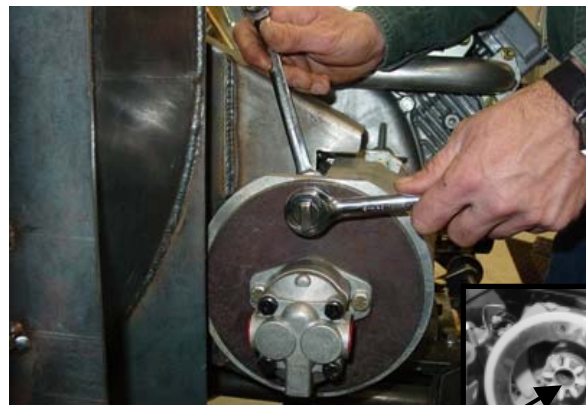

RUBBER INSERT

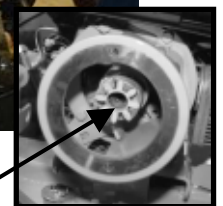



**BELTS AND SHEAVES**

- When just replacing the belt, it will not be necessary to check sheave alignment. Go back to the **BELT TENSION** section and check and adjust belt tension. You may need to reduce belt tension a good amount for a new belt if the old belt had been adjusted several times.
- Remember new belts will stretch and become loose as machine runs. Check belt tension often when belts are new.
- Replace the pump drive making sure the rubber insert is in place.

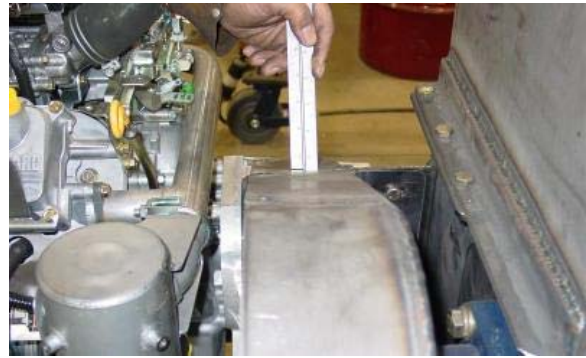

RUBBER INSERT

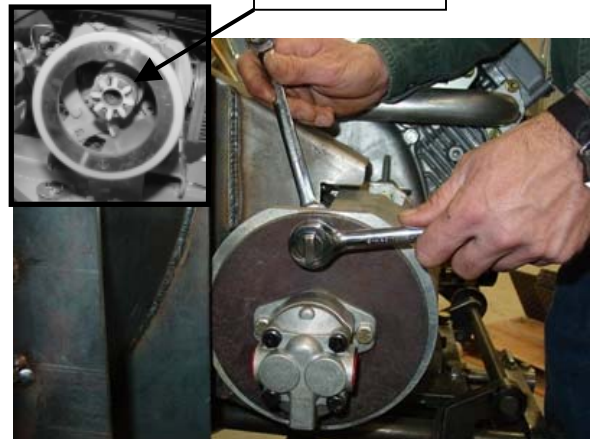

- ALWAYS REMEMBER TO REPLACE BELT GUARDS BEFORE STARTING MACHINE. ROTATING BELTS AND SHEAVES ARE DANGEROUS AND COULD SEVERELY INJURE SOMEONE.



**BELTS AND SHEAVES**

**REPLACING SHEAVE OR BUSHING**

- If it becomes necessary to replace a sheave or bushing, replace only one at a time. Never remove both sheaves at the same time.
- This section covers removing and replacing the cutter disk sheave. Follow the same procedure for removing the engine sheave.
- Remove belt guard bolts and remove guard.
- Mark position of bushing on shaft before removing sheave to check bushing position when replaced.
- Remove belts as described in REPLACING BELTS section.
- Remove the three bolts holding the sheave to the bushing.
- Screw a 1/4"-20 bolt into each of the three threaded holes to push sheave off bushing. Screw bolts in equally to prevent damaging the bushing or the sheave, especially if you plan to use either one again.
- Remove the sheave and replace with new sheave.



**BELTS AND SHEAVES**

- Replace bolts in the sheave and tighten lightly.
- Check the mark you made earlier next to the bushing. If bushing was not moved in replacing the sheave, tighten screws.
- If bushing is replaced or moved on the shaft, realign the sheaves using a 2-foot straight edge across the engine and cutter disk sheaves.
- Go to REPLACING ENGINE BELT section to replace belt and adjust tension.
- ALWAYS REMEMBER TO REPLACE BELT GUARD COVER BEFORE STARTING MACHINE. ROTATING BELTS AND SHEAVES ARE DANGEROUS AND COULD SEVERELY INJURE SOMEONE.





**FEED WHEEL MOTOR**

**⚠ DANGER**

**DO NOT PERFORM MAINTENANCE OF ANY KIND ON THIS MACHINE UNLESS:**

- ◆ The engine is turned off
- ◆ The ignition key has been removed
- ◆ The positive battery cable has been disconnected
- ◆ The feed control bar is in neutral
- ◆ All machine parts have come to a complete stop – NOTE: The cutter disk takes several minutes to come to a complete stop
- ◆ All machine parts have had sufficient time to cool down
- ◆ The cutter disk lock pin is installed in the disk lock tube
- ◆ No operator is in position at the controls to accidentally start machine
- ◆ At least 2 people are at the site where maintenance is performed

More accidents occur while performing maintenance than any other time! Use extra caution.

**Never** perform maintenance with the engine running, not even with the belt(s) disengaged.

**CUTTER WHEEL IS ENGAGED WHEN ENGINE IS RUNNING.**

**ALWAYS REPLACE GUARDS AND OTHER PROTECTIVE EQUIPMENT BEFORE STARTING CHIPPER AFTER PERFORMING MAINTENANCE.**

**There is a special tool required to separate the motor and coupling once it is off the machine, contact J. P. Carlton or your local dealer to purchase the puller.**

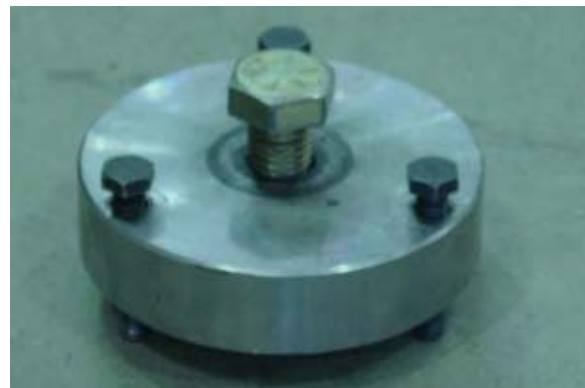

PULLER

**FEED WHEEL MOTOR**

**WARNING:**

- **RELEASE HYDRAULIC PRESSURE BEFORE PERFORMING ANY SERVICE TO HYDRAULIC LINES OR OTHER COMPONENTS.**
- **FLUID UNDER PRESSURE CAN PENETRATE THE SKIN AND CAUSE SEVERE INJURY. SEEK IMMEDIATE MEDICAL ATTENTION IF SKIN IS PENETRATED. CHECK HOSES AND FITTINGS USING A BOARD OR CARDBOARD; DO NOT USE HAND OR FINGER. ALWAYS WEAR EYE PROTECTION.**

The pictures shown in this section may not look exactly like your machine, but the information given and the process for servicing the feed wheels is correct.

- Before changing feed wheel motor, release the hydraulic pressure. Mark the location of each hose, possibly with an R and L for right and left hoses. Then disconnect the hydraulic hoses and cap the ends of hoses and the connections on the motor.
- Remove the rubber guard that covers the feed wheel coupling and bushing by removing the two 3/8" bolts. Be sure to keep all parts and hardware together to make reassembly easier.
- Remove the three bolts (3/8") from the bushing and screw these bolts back into the three threaded holes in the bushing to push the motor assembly off the bushing. Screw these bolts in a little at a time to take the assembly off without applying more pressure to one side than the other.



**FEED WHEEL MOTOR**

- When the motor assembly is off the machine, move it to a workbench for easier access. Then, remove the 1" nut that is inside the coupling. You may need to use a vise to hold the motor steady while you break the nut loose since it was put on with LocTite® 262 and then tightened to 150 ft. lbs.  
**CAUTION: Always wear eye protection when working on hydraulic components.**
- **There is a special tool required to separate the motor and coupling once it is off the machine, contact J. P. Carlton or your local dealer to purchase the puller.**
- Attach the separating tool to the coupler as shown and screw the three bolts from the bushing into the tool in the outside holes. Screw the bolts into the coupling as far as they will go. Now turn the bolt in the center of the tool to pull the coupling off the feed wheel motor.
- Remove the torque arm held on with two 1/2" bolts. (The torque arm looks slightly different on the lower feed motor, but is still held on with two bolts.)

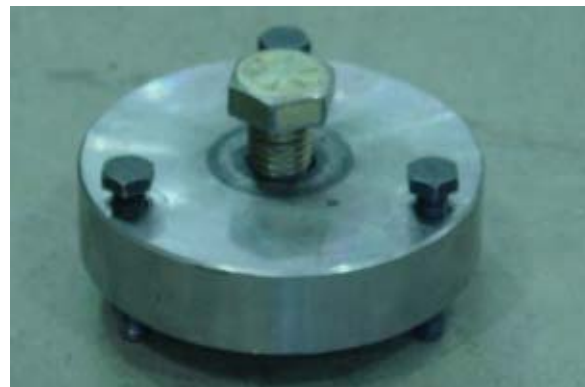



**FEED WHEEL MOTOR**

- Replace with new motor. Clean the threads on the motor, the 1" nut, and the coupling with degreaser before beginning to replace all the parts.



- Attach the torque arm to the new motor using the 1/2" bolts that were removed. Tighten the bolts and torque to 120 ft. lbs. (The torque arm looks slightly different on the lower feed motor, but is still held on with two bolts.)



LINE UP KEY WITH KEYWAY ON COUPLING

HIT COUPLING WITH RUBBER Mallet TO SEAT

- Put the coupling onto the motor and line up key and keyway – always use new key. Use a rubber mallet to seat the coupling. Strike the coupling a couple of times. Apply LocTite 262 (red) to the 1" nut and screw in place. Torque the nut to 150 ft. lbs. Strike the coupler again a couple of times with the rubber mallet to finish seating and torque the nut to 150 ft. lbs. again.



**FEED WHEEL MOTOR**

- Return the feed wheel motor assembly to the machine and tighten the bolts in the bushing. Tighten each bolt a little at a time to pull the coupling into place as straight as possible. Try not to pull one side on faster than the other or damage may occur to the bushing and the coupling. When bolts are screwed in all the way, torque the bolts to 35 ft. lbs.



- Replace the rubber guard and bolt into place using the two 3/8" bolts that were removed. Tighten the bolts.



- Reconnect the hydraulic hoses making sure to connect them in the right order, see markings made when hoses were removed. If hoses are reversed, the feed wheels will work in reverse. Change hoses if this happens to make feed wheels turn correctly.





CHIPPER WIRING DIAGRAM – KOHLER ENGINE

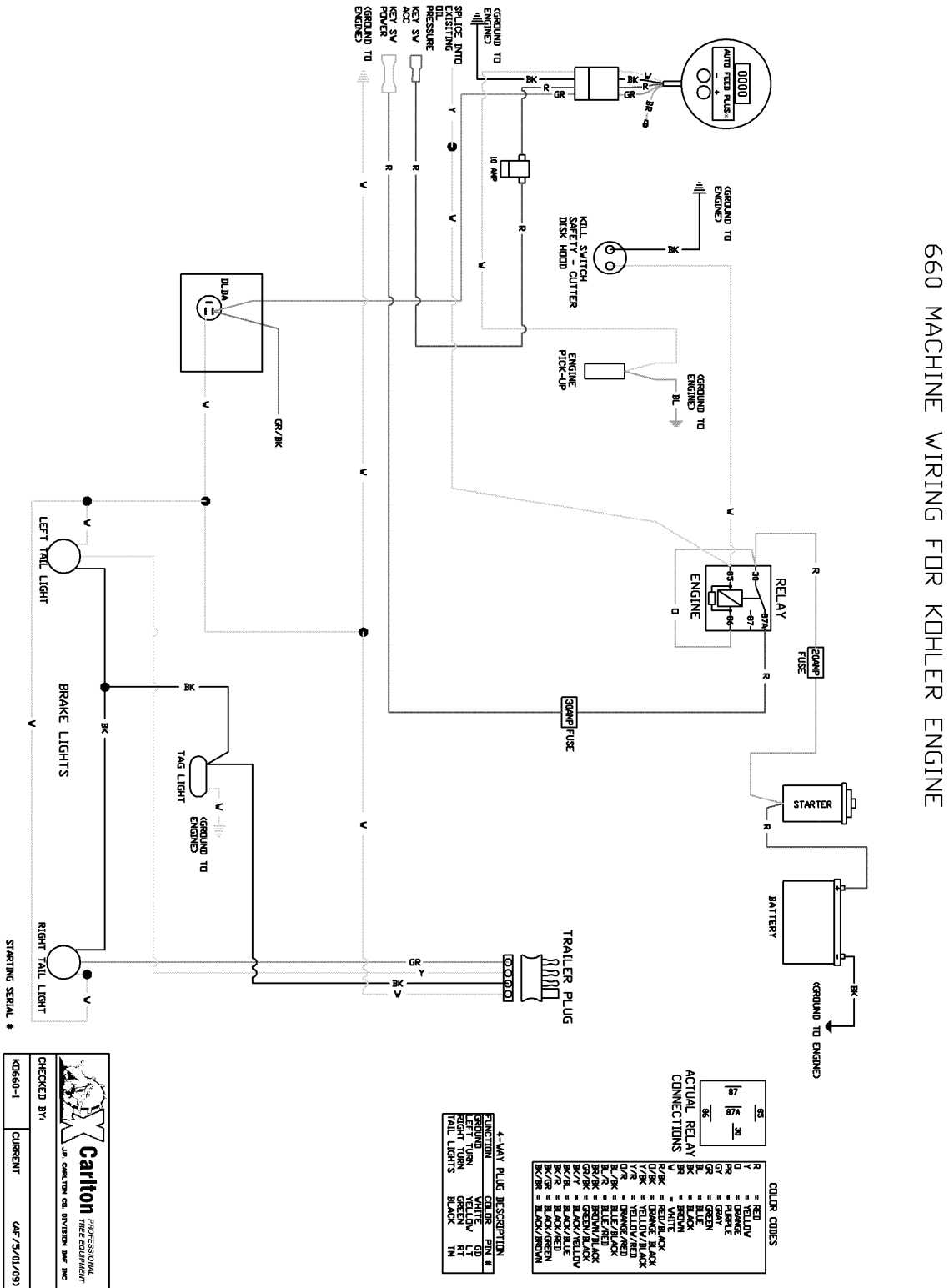

WIRING MAY BE DIFFERENT DEPENDING ON ENGINE SUPPLIED WITH THE CHIPPER. SEE THE ENGINE OWNER'S MANUAL FOR THE ENGINE WIRING DIAGRAM

**CHIPPER – LEFT SIDE**

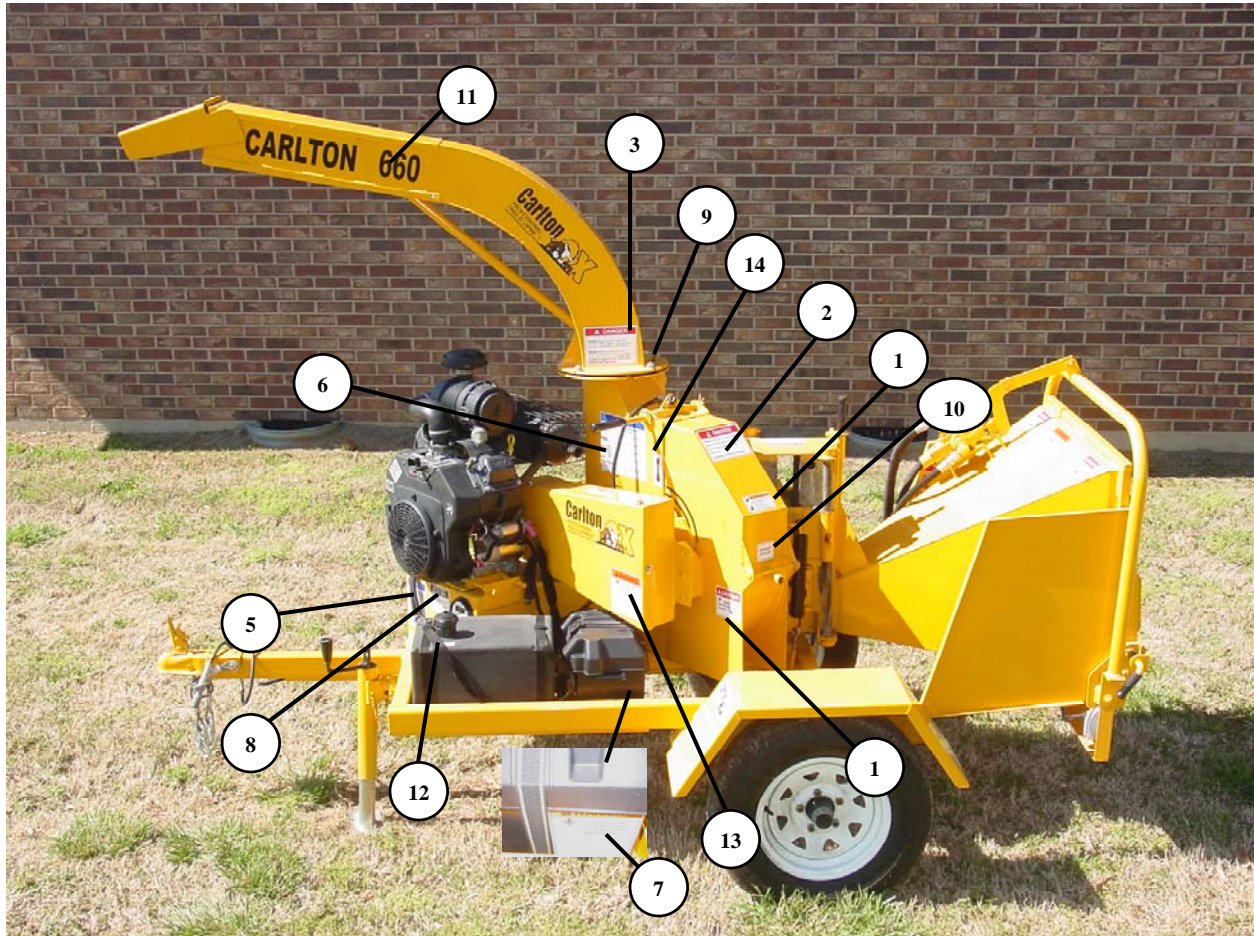

ITEM #	PART #	DESCRIPTION
1	0700301	DANGER – MOVING PARTS
2	0700302	DANGER – SERVICING
3	0700303	DANGER – NEVER RIDE ON, ETC.
4	0700306	DANGER – AIRBORNE CHIPS
5	0700309	PINCH POINTS
6	0700313	NOTICE – CHIPPER KNIFE
7	0700314	WARNING – FROZEN BATTERY
8	0700320	AUTO-FEED ON/OFF INFO.
9	0700322	SOLID ARROW (2 PLCS)
10	0700323-2	DISK/DRUM LOCK PIN
11	0700127	CARLTON – 660
12	0700003	GASOLINE ONLY
13	0700315	WARNING – HEARING/EYE PROTECTION
14	0700321_A	GREASE DAILY



**CHIPPER – RIGHT SIDE**

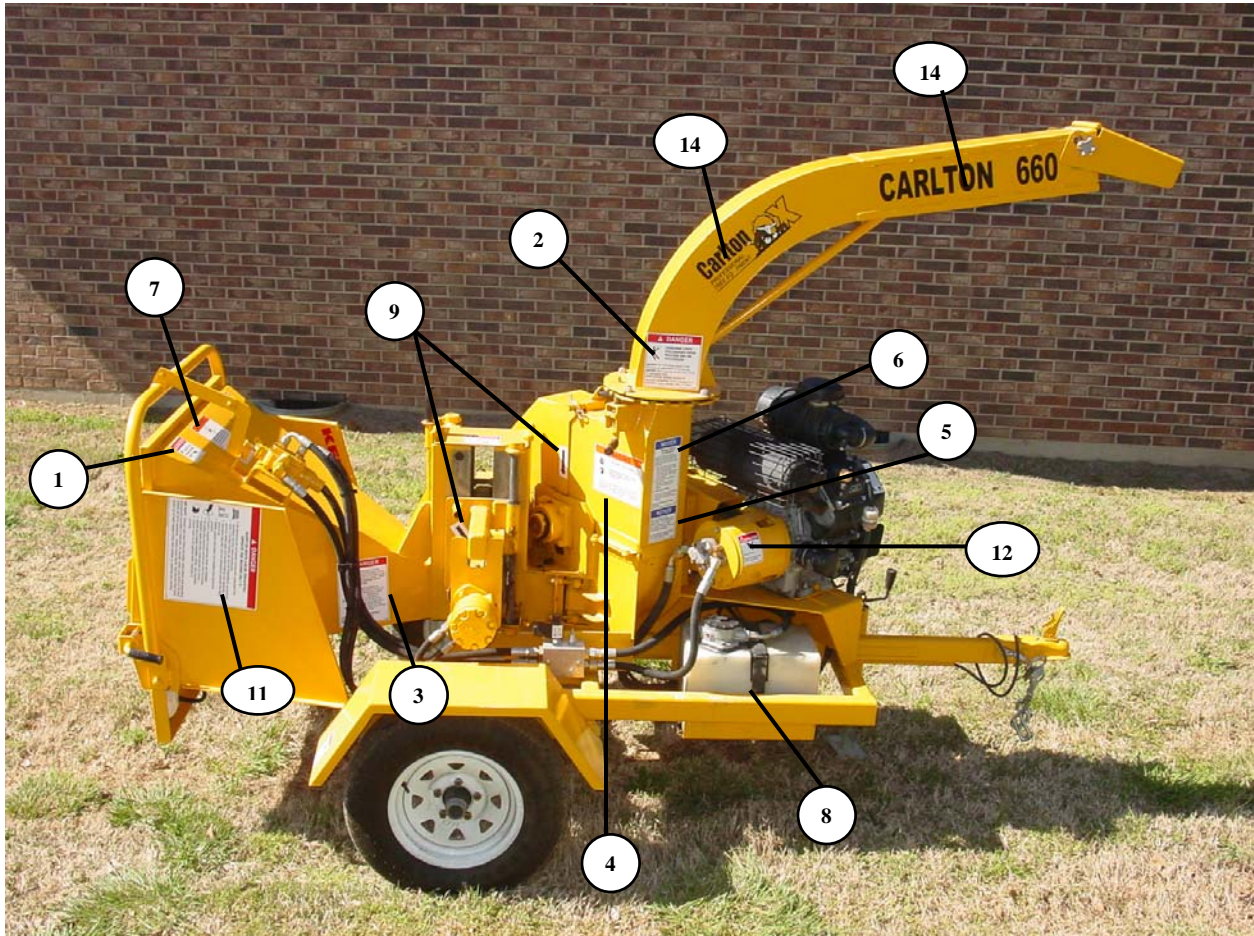

ITEM #	PART #	DESCRIPTION
1	0700301	DANGER – MOVING PARTS
2	0700304	DANGER – AIRBORNE CHIPS
3	0700305_A	DANGER – FEED WHEEL SERVICE
4	0700307	DANGER – INJURY/DEATH
5	0700309	NOTICE – DECAL MAINTENANCE
6	0700311	NOTICE – BELT/BEARING MAINTENANCE
7	0700317	WARNING – PRESSURE LEAKS
8	0700319	HYDRAULIC OIL INFO.
9	0700321 A	GREASE DAILY (TYP BOTH SIDES)
10	0700324-2	YOKE LOCK HOLE
11	0700327	DANGER – FEED HOPPER
12	JPC09	
13	0700127	CARLTON – 1260
14	0700155	CARLTON – PROFESSIONAL TREE EQUIPMENT



**CHIPPER – REAR**



ITEM #	PART #	DESCRIPTION
1	0700060	CARLTON OX DECAL
2	0700301	DANGER – MOVING PARTS
3	0700318	PUSH – REVERSE
4	0700600	DNAGER KEEP CLEAR



Parts Book

# Carlton

**PROFESSIONAL  
TREE EQUIPMENT**

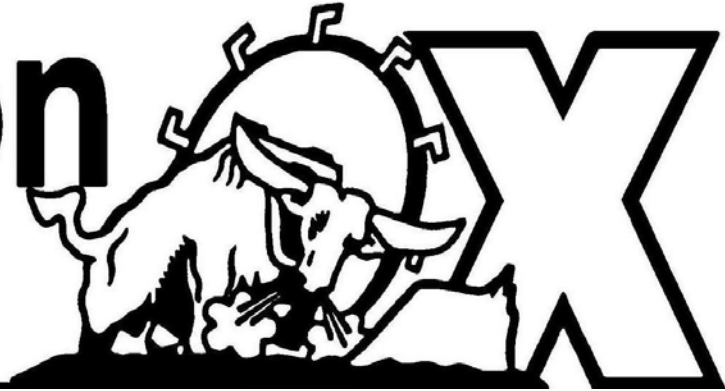

Carlton

J.P. Carlton Company  
Div. D.A.F. Inc.  
121 John Dodd Road  
Spartanburg, SC 29303  
Ph. (864) 578-9335  
Fax (864) 578-0210  
[www.stumpcutters.com](http://www.stumpcutters.com)

## 660 CHIPPER

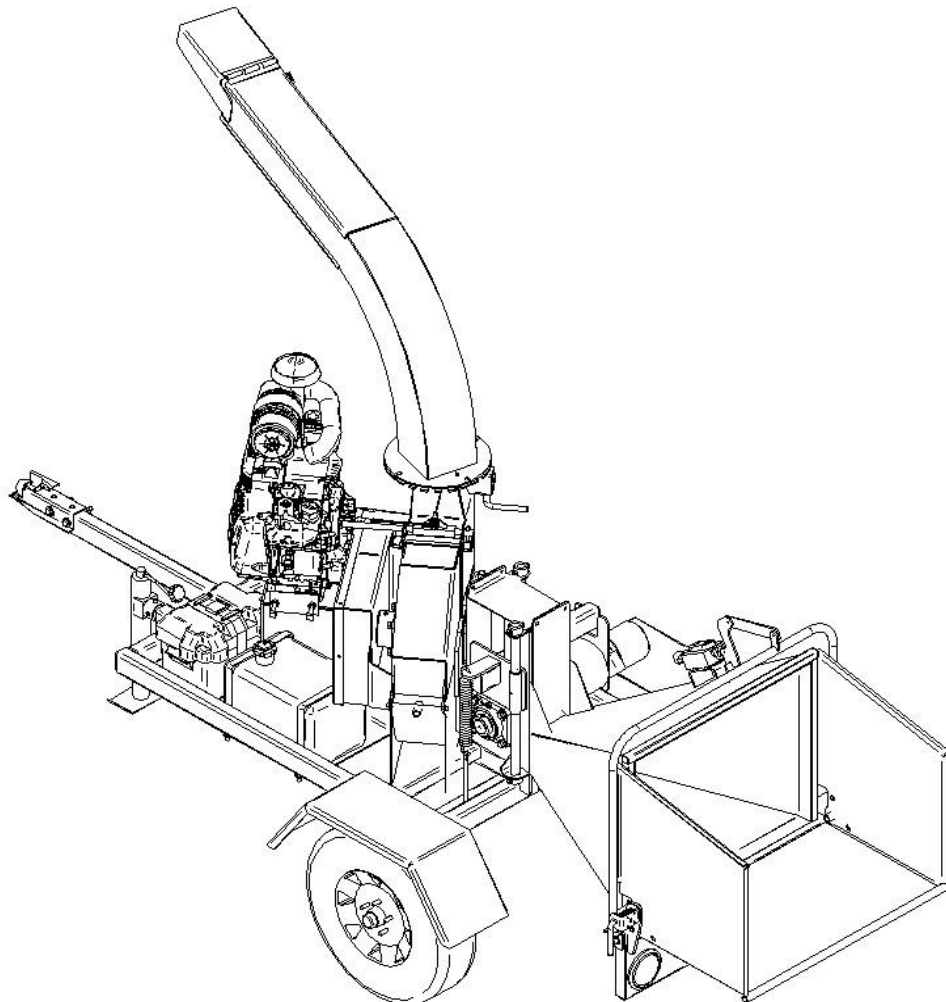

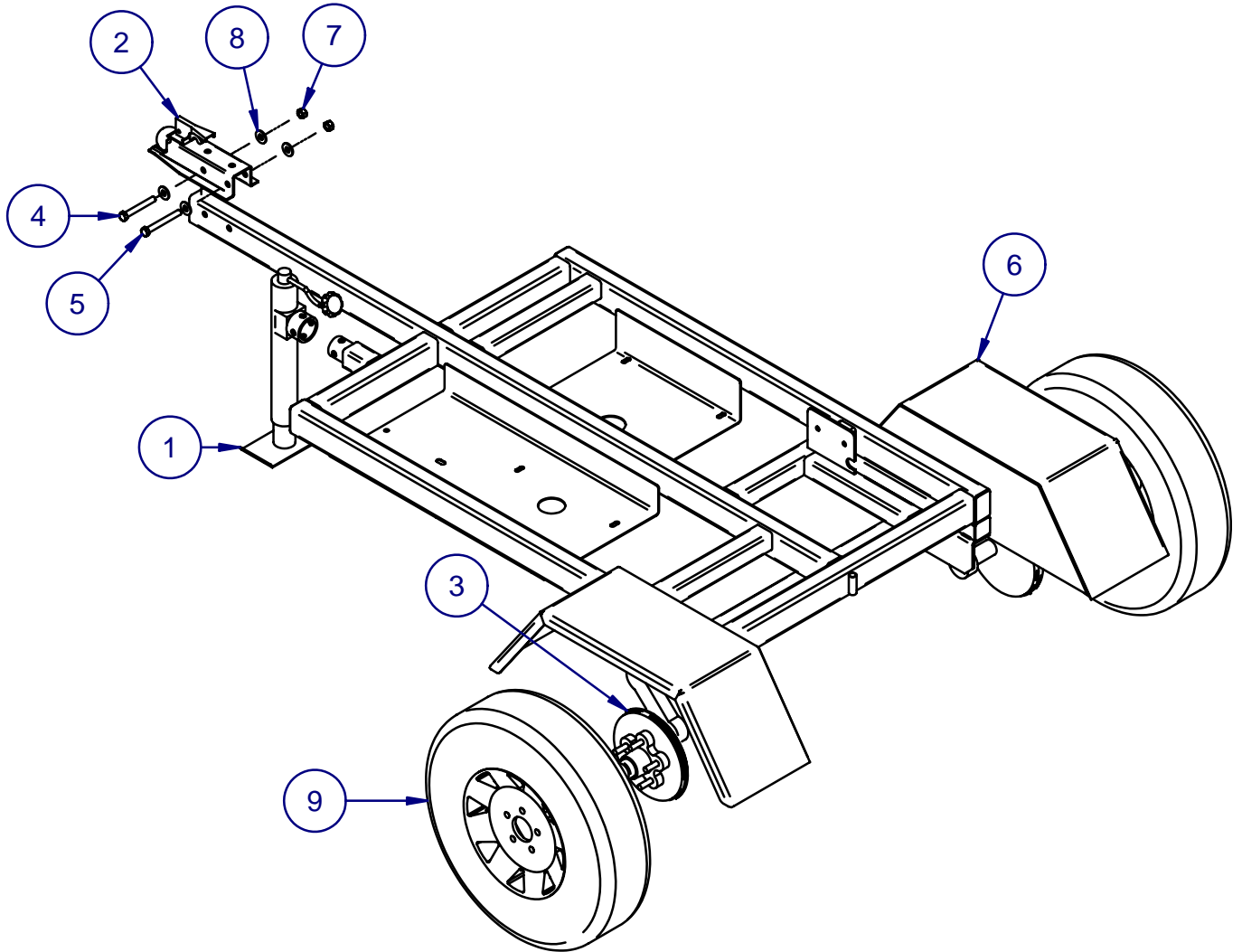

PART	ITEM	DESCRIPTION	QTY
1	0550004H	Jack-2K Top Mount- 6" Chipper	1
2	0550004I	Trailer Coupler 2 inch ball	1
3	0550250K	TORSION FLEX AXLE - #9 - 2000	1
4	12A-0830ZI	HEX C/S 1/2-13 x 3 3/4 UNC GR 8	1
5	12A-0844ZI	HEX C/S 1/2-13 x 4 1/4 UNC GR 8	1
6	20510002	WELDMNT,FRAME	1
7	20A-08	NUT,HEX,1/2-13 UNC GR8	2
8	31A-08ZI	FLAT WASHER 1/2 USS GR 8 Z&Y	4
9	ST175/80R13	ST175/80R13 Ld Rng C 1760 # @ 50 PSI	2

FUNCTION GROUP	
<b>1 FRAME AND AXLE</b>	
BUSINESS LINE	
<b>CHIPPERS</b>	
OWNER DOMAIN J.P. CARLTON COMPANY DIV. DAF INC.	
SERIAL NUMBERS 1J9UE021491167062	
DESCRIPTION	ISSUE
<b>AXLE, TIRES AND RIMS</b>	<b>R1</b>

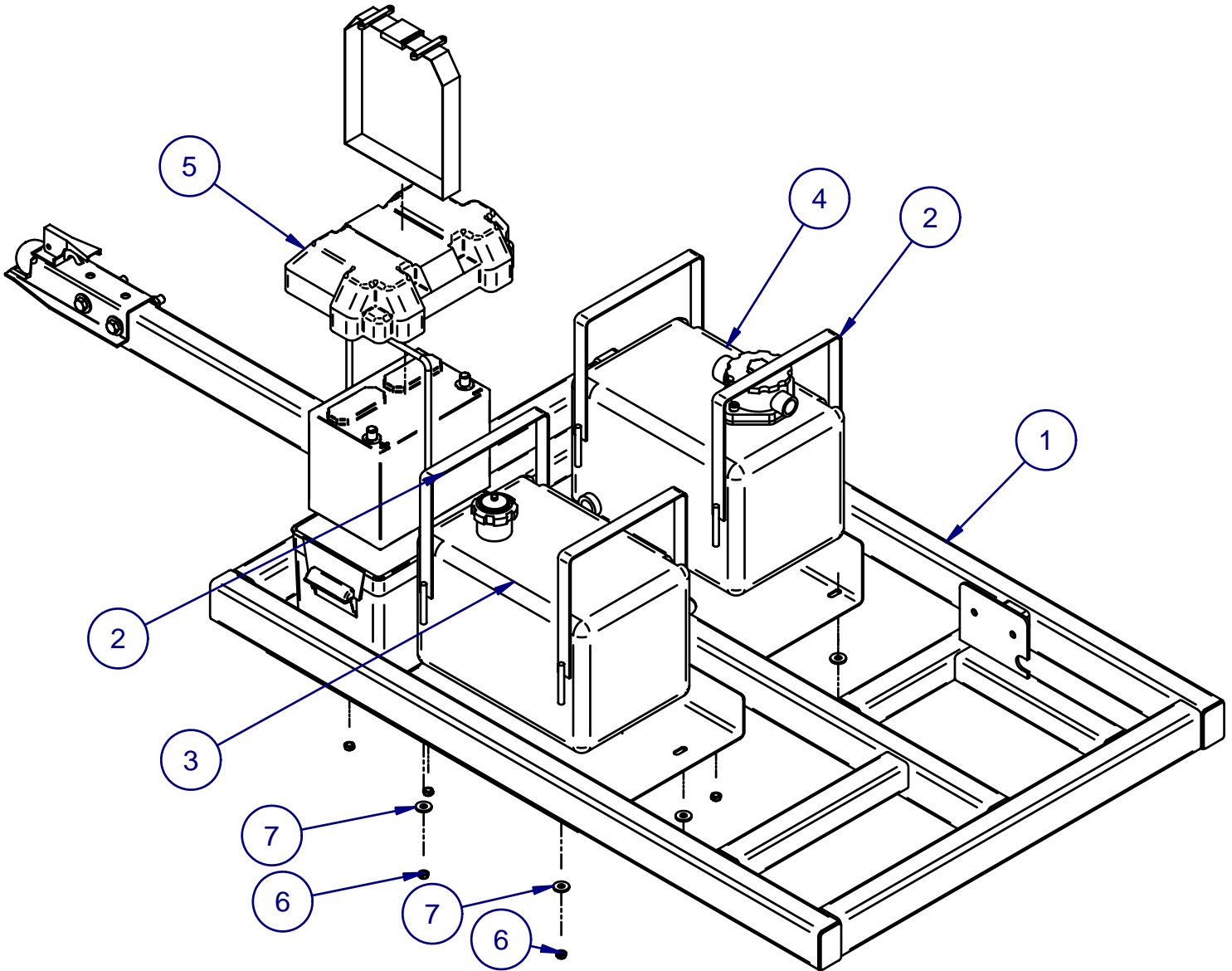

PART	ITEM	DESCRIPTION	QTY
1	20510001	ASSY,FRAME	1
2	20510013	WELDMENT,TANK STRAP	4
3	20510019	ASSY,FUEL TANK	1
4	20510020	ASSEMBLY,HYDRAULIC TANK	1
5	20620011	ASSY,BATTERY BOX	1
6	29A-06	NUT,STOVER LOCK, 3/8-16 UNC GR8	8
7	31A-06	FLAT WASHER, 3/8 USS GRD 5	8

FUNCTION GROUP	
1 FRAME AND TANKS	
BUSINESS LINE	
CHIPPERS	
OWNER DOMAIN J.P. CARLTON COMPANY DIV. DAF INC.	
SERIAL NUMBERS 1J9UE021491167062	
DESCRIPTION	ISSUE
BATTERY, HYDRAULIC, AND FUEL TANK INSTALL	R1



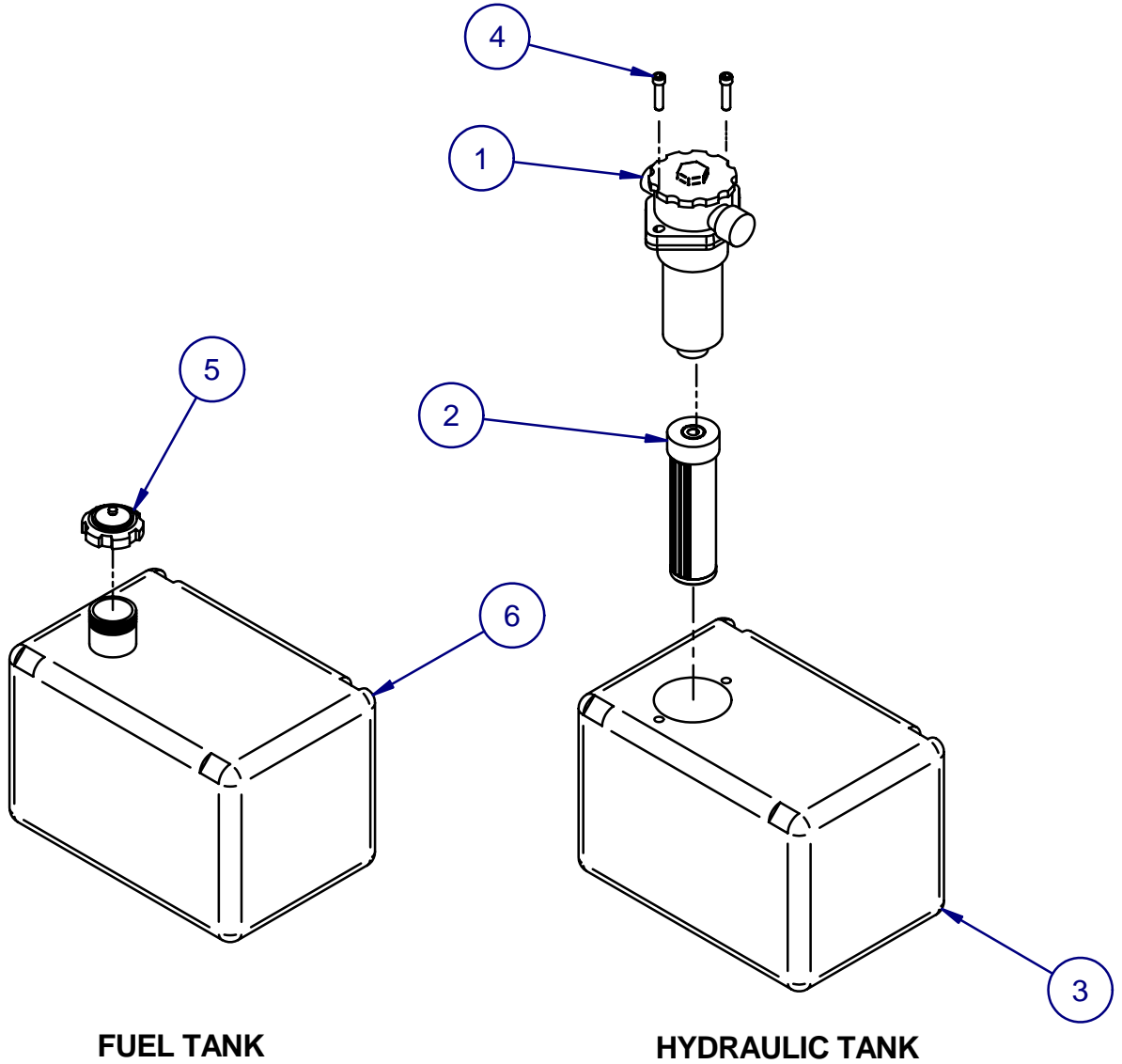

PART	ITEM	DESCRIPTION	QTY
1	0300135E	HYDRAULIC IN TANK FILTER STF	1
2	0300135F	HYDRAILIC IN TANK FILTER ELEME	1
3	0300176	TANK, HYDRAULIC	1
4	12D-0612	SHCS 3/8 X 1-1/2 NC GR 8	2
5	0200008	Fuel Cap - Plastic Tank	1
6	0200146	TANK, FUEL	1

FUNCTION GROUP	
<b>1 FRAME AND TANKS</b>	
BUSINESS LINE	
<b>CHIPPERS</b>	
OWNER DOMAIN	
J.P. CARLTON COMPANY DIV. DAF INC.	
SERIAL NUMBERS	
1J9UE021491167062	
DESCRIPTION	ISSUE
<b>HYDRAULIC AND FUEL TANKS</b>	<b>R1</b>

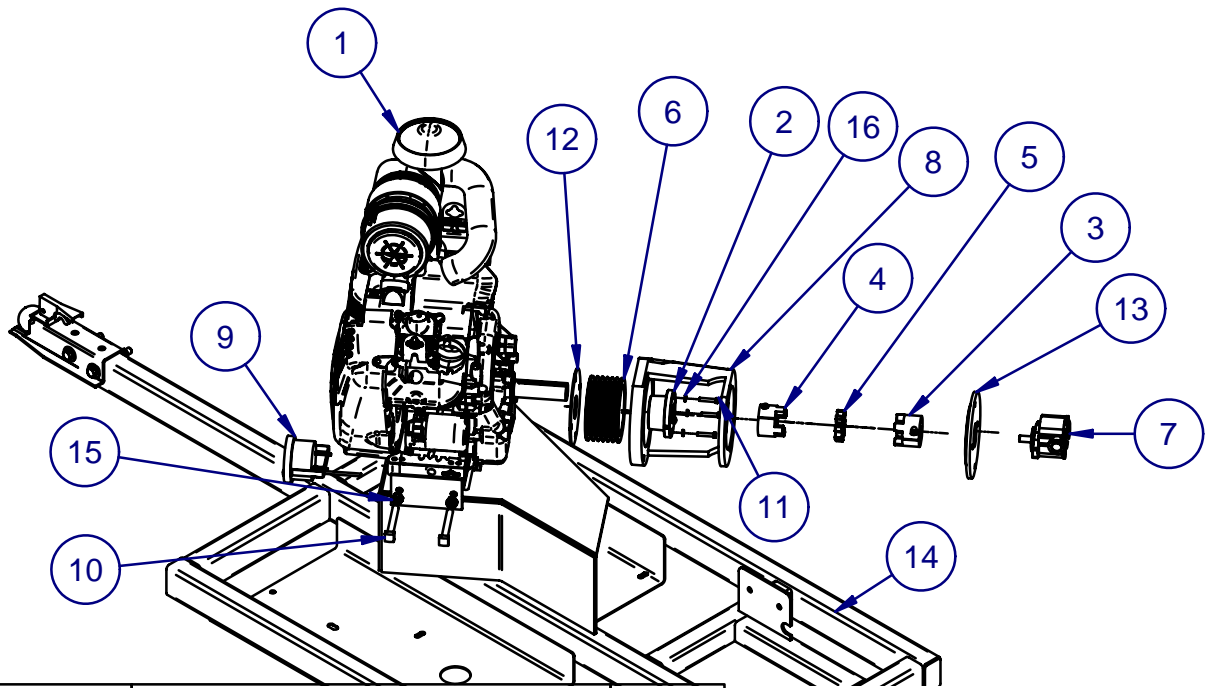

PART	ITEM	DESCRIPTION	QTY
1	0200102AA	Engine - 27 HP Kohler	1
2	0250119	BUSHING,SH 1-7/16	1
3	0250132A	COUPLING 9 TOOTH A- 6" CHIPPER	1
4	0250133	COUPLING - 23/25 ENGINE	1
5	0250134	SPIDER INSERT - 23/25	1
6	0250322	SHEAVE,3V5.3, 1-7/16 BUSHING	1
7	0300142AAA	PARKER HYD PUMP - 2500-4'S	1
8	05506102	CASTING,BEE HIVE,KOHLER	1
9	0900205	ELECTRONIC AUTO FEED	1
10	10D-0832ZI	SQUARE HEAD BOLT,1/2-13 x 4 UNC GR 8	2
11	12A-0411	HEX C/S 1/4-20 x 1-375 UNC GR 8	3
12	14020023	PLATE,ENGINE SEAL,KOHLER/BRIGGS	1
13	14020024	MOUNT,CRANK SHAFT HYDRAULIC PUMP	1
14	20520003	WELDMENT,ENGINE INSTALL	1
15	20A-08ZI	NUT,HEX,1/2-13 UNC Z&Y GR8	4
16	30A-04	LOCKWASHER,1/4" USS GR8	3

FUNCTION GROUP	
<b>2 ENGINE AND ELECTRICAL</b>	
BUSINESS LINE	
<b>CHIPPERS</b>	
OWNER DOMAIN J.P. CARLTON COMPANY DIV. DAF INC.	
SERIAL NUMBERS 1J9UE021491167062	
DESCRIPTION	ISSUE
<b>ENGINE INSTALL</b>	<b>R1</b>

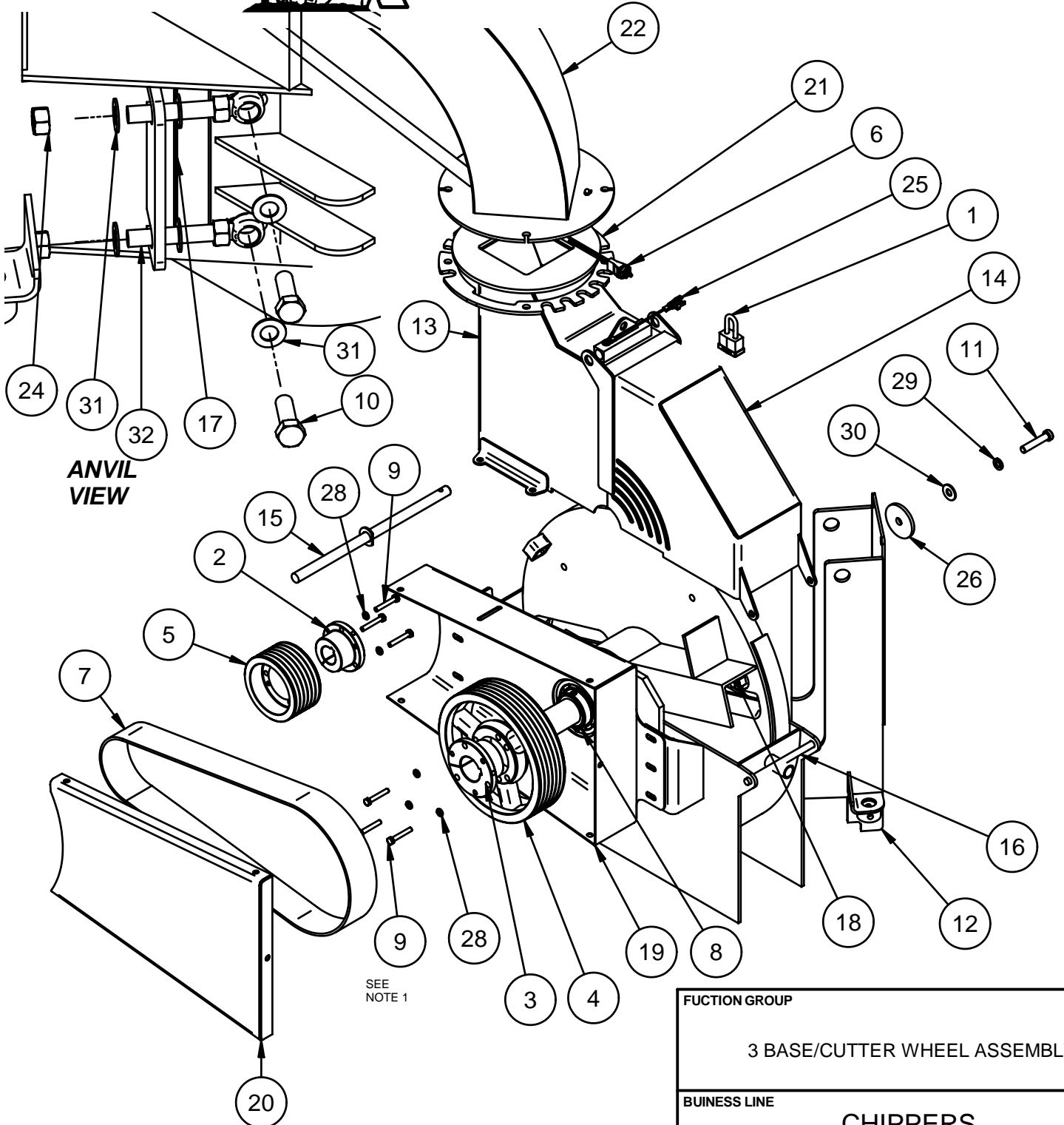

**ANVIL  
VIEW**

SEE  
NOTE 1

**NOTES:**

1. ITEM #9 (12A-0516) TORQUE 15 FT/LBS.
2. APPLY BLUE LOCTITE 242 AND TORQUE 95FT/LBS TYP FOR ITEM #10 (12A-0812ZI) .
- SET SCREW TORQUE 18FT/LBS

FUNCTION GROUP	
3 BASE/CUTTER WHEEL ASSEMBLY	
BUSINESS LINE	
CHIPPERS	
OWNER DOMAIN	
J.P. CARLTON COMPANY DIV. DAF INC.	
SERIAL NUMBERS	
1J9UE0122B1167108 AND UP	
DESCRIPTION	ISSUE
BASE/CUTTER WHEEL ASSY	R2

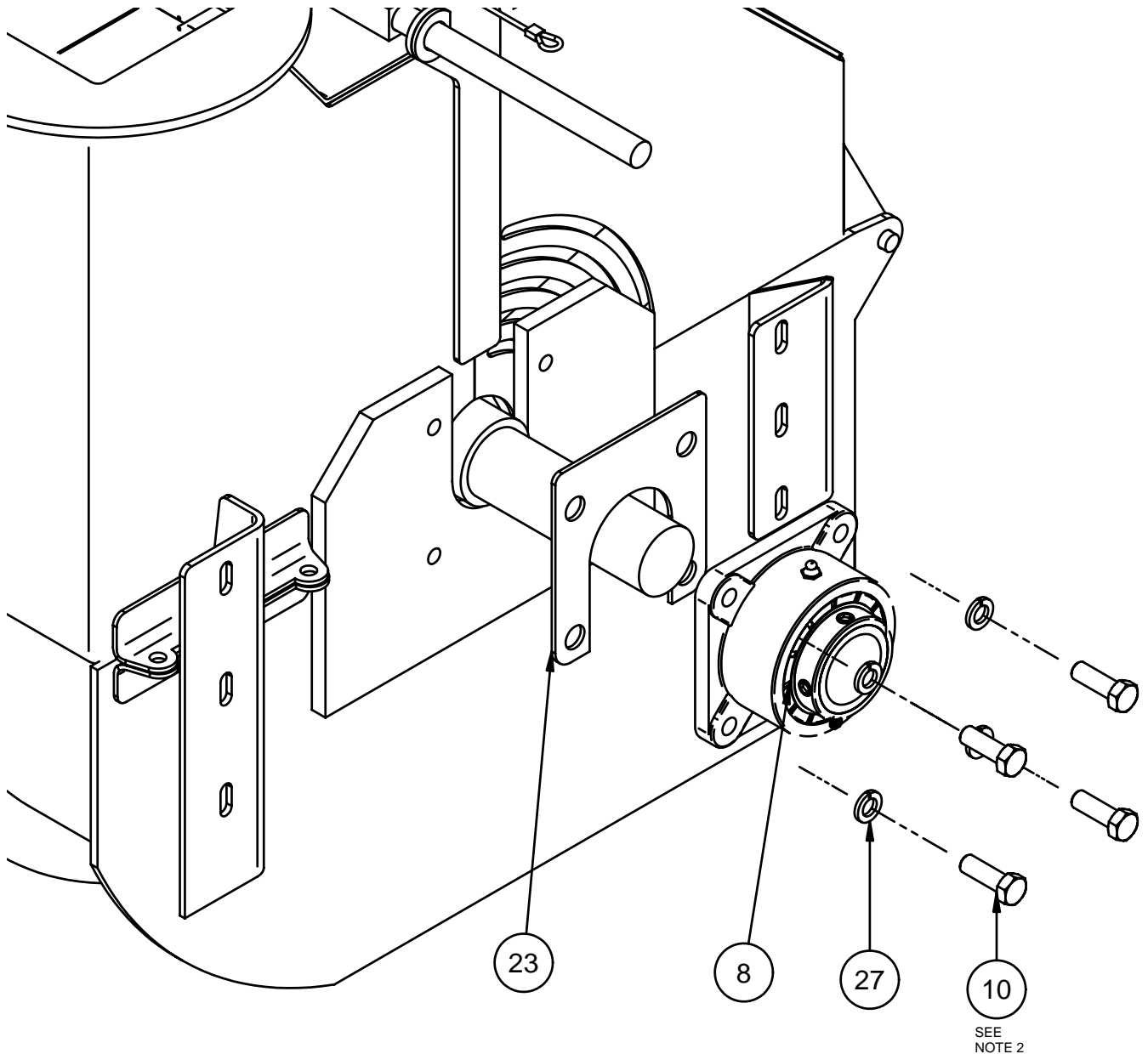

FUNCTION GROUP	
3 BASE/CUTTER WHEEL ASSEMBLY	
BUSINESS LINE	
CHIPPERS	
OWNER DOMAIN J.P. CARLTON COMPANY DIV. DAF INC.	
SERIAL NUMBERS 1J9UE0122B1167108 AND UP	
DESCRIPTION	ISSUE
BASE/CUTTER WHEEL ASSY	R2



PART	ITEM	DESCRIPTION	QTY
1	0150608	MASTER LOCK	1
2	0250119	BUSHING,SH 1-7/16	1
3	0250124	BUSHING - 65/75 ENGINE - SF 2"	1
4	0250319	SHEAVE,CUTTER WHEEL,KUBOTA	1
5	0250322	SHEAVE,3V5.3, 1-7/16 BUSHING	1
6	0350013	SWITCH - LANYARD - OPEN	1
7	0400141	Belt Lom/660 Chipper R3V630-6	1
8	0500153	BEARING,2" FLANGE	1
9	12A-0516	HEX C/S 5/16-18 x 2 UNC GR 5	6
10	12A-0812ZI	HEX C/S 1/2-13 x 1-1/2 UNC GR 8 Z&Y	6
11	12D-0820	SOC HD C/S 1/2-13 X 2-1/2" UNC BLCK	1
12	20530002	WELDMNT,BASE/THROAT	1
13	20530003	WELDEMNT,TRANSITION	1
14	20530004	WELDMNT,DOOR	1
15	20530024	WELDMNT,LOCK PIN,DOOR	1
16	20530025	ROUND BAR,DOOR HINGE	1
17	20530026	ANVIL	1
18	20530027	ASSEMBLY,CUTTER WHEEL	1
19	20530039	WELDMNT,BELT GUARD BACK	1
20	20530040	WELDMNT,BELT GUARD COVER	1
21	20530047	PLATE,DISCHARGE ADJUST SPROCKET	1
22	20560001	ASSY,DISCHARGE SYSTEM	1
23	20630010	SHIM,CUTTER WHEEL BEARING	1
24	20A-08	NUT,HEX,1/2-13 UNC GR8	4
25	21230114	WIRE,LANYARD SWITCH,DOOR LOCK,LATCH	1
26	21240075	WASHER,FEED WHEEL BEARING	1
27	30-08	LOCK WASHER,1/2"	4
28	30A-05	LOCKWASHER 5/16" USS GR8	5
29	30A-08ZI	LOCK WASHER,1/2" USS GR8 Z&Y	1
30	31A-08ZI	FLAT WASHER 1/2 USS GR 8 Z&Y	1
31	31B-08ZI	FLAT WASHER 1/2 USS NARROW GR 8 Z&Y	6
32	TBD	1/2-13 x 3-1/2" ROD END, YELL	2

<b>FUNCTION GROUP</b>	
3 BASE/CUTTER WHEEL ASSEMBLY	
<b>BUINESS LINE</b>	
CHIPPERS	
<b>OWNER DOMAIN</b> J.P. CARLTON COMPANY DIV. DAF INC.	
<b>SERIAL NUMBERS</b> 1J9UE0122B1167108 AND UP	
<b>DESCRIPTION</b>	<b>ISSUE</b>
BASE/CUTTER WHEEL ASSY	R2



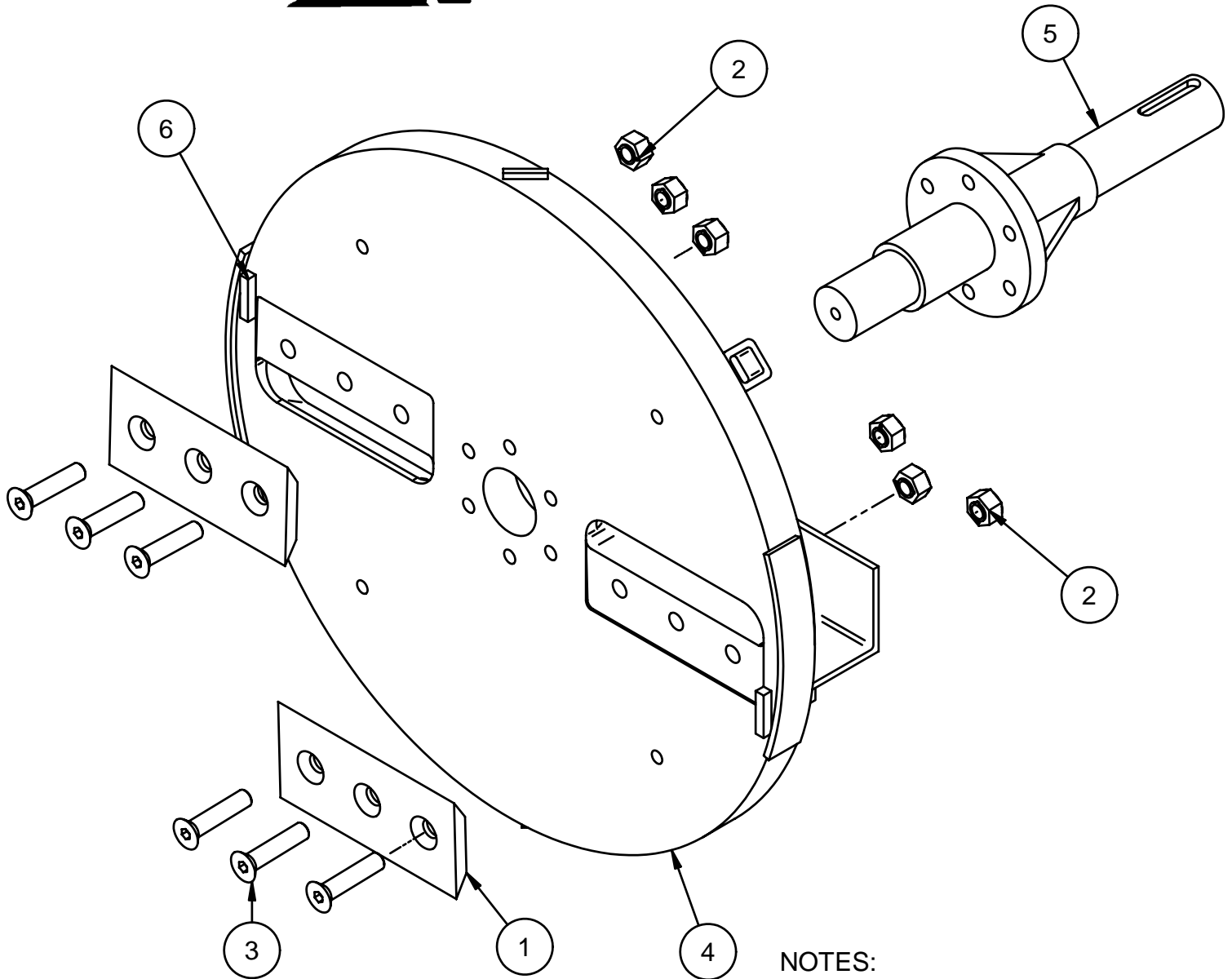

SEE NOTE 1

NOTES:  
1. TORQUE BOLTS( ITEM #3) TO  
180FT/LBS

PART	ITEM	DESCRIPTION	QTY
1	0900114R1	KNIFE,8.375X4X.50	2
2	0900129	CHIPPER KNIFE BOLT NUT - 5/8"	6
3	0900130	CHIPPER KNIFE BOLT - 5/8"	6
4	20530028	WELDMENT, CUTTER WHEEL	1
5	20630051	SHAFT,CUTTER WHEEL,MACHINED	1
6	70A-0614	KEY ,3/8 SQ. 1-3/4" LONG	2

FUNCTION GROUP	
3 BASE/CUTTER WHEEL	
BUSINESS LINE	
CHIPPERS	
OWNER DOMAIN J.P. CARLTON COMPANY DIV. DAF INC.	
SERIAL NUMBERS 1J9UE0122B1167108 AND UP	
DESCRIPTION	ISSUE
CUTTER WHEEL ASSY	R2

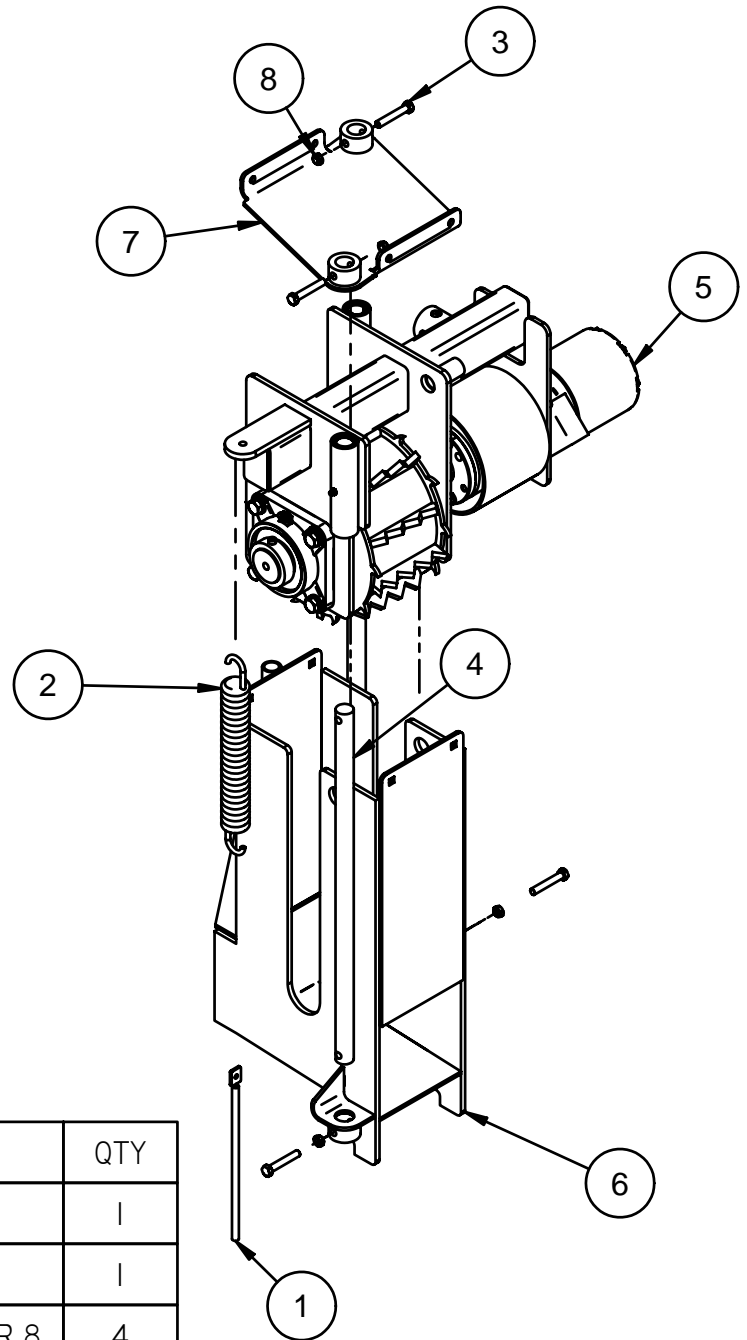

PART	ITEM	DESCRIPTION	QTY
1	0900104	SPRING TIGHTENER FOR 250	1
2	0900110B	SPRING,LIFT	1
3	12A-0618	HEX C/S 3/8-16 x 2-1/4 UNC GR 8	4
4	14040045	ROD,ENGINE SLIDE	2
5	20540002	ASSY, TOP FEED	1
6	20540004	WELDMENT,BTM FEED	1
7	20540005	WELDMENT, TOP PLATE	1
8	29A-06	NUT,STOVER LOCK, 3/8-16 UNC GR8	4

FUNCTION GROUP	
4 FEED SYSTEM	
BUSINESS LINE	
CHIPPERS	
OWNER DOMAIN	
J.P. CARLTON COMPANY DIV. DAF INC.	
SERIAL NUMBERS	
1J9UE021491167062	
DESCRIPTION	ISSUE
FEED SYSTEM	R2

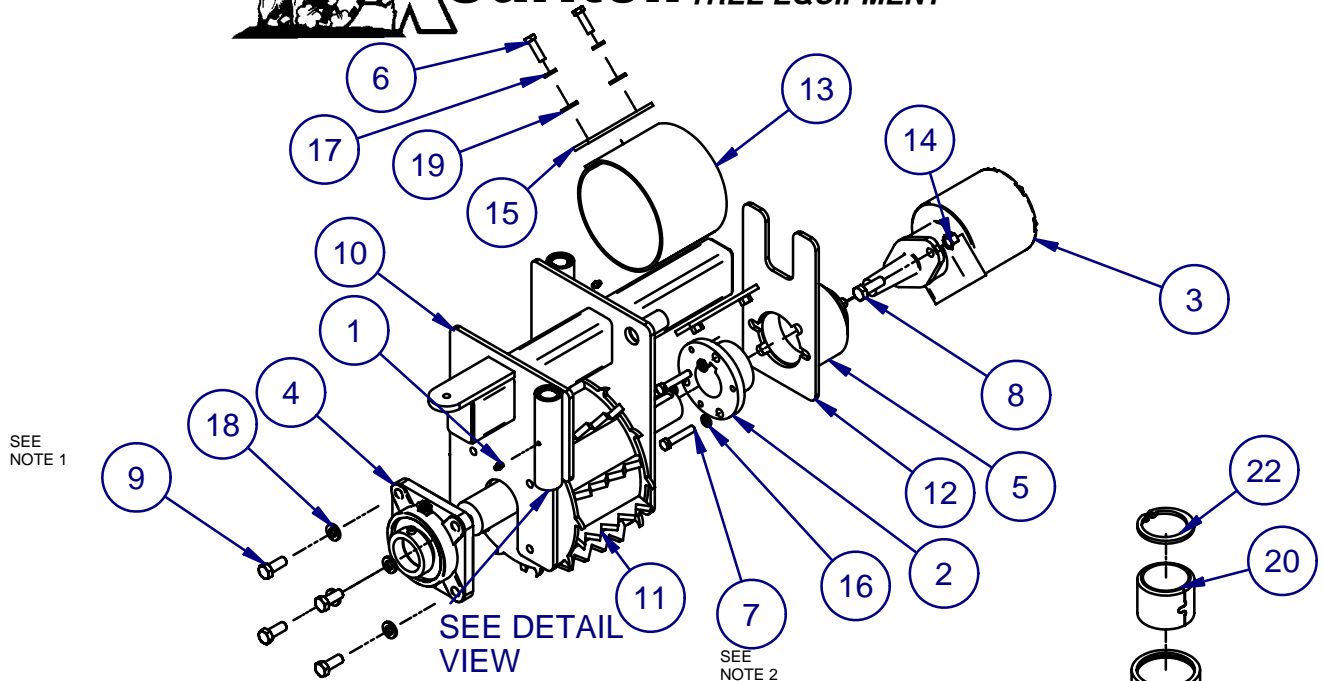

PART	ITEM	DESCRIPTION	QTY
1	0150601	GREASE FITTING 1/4-28 STRAIGHT	2
2	0250124	BUSHING - 65/75 ENGINE - SF 2"	1
3	0300044	6" CHIPPER TOP HYD MOTOR	1
4	0500152	FB 2" LINKBELT-FEEDWHEEL, CHIP	2
5	I200188	COUPLER, FEED WHEEL HUB	1
6	I2A-0610ZI	HEX C/S 3/8-16 x 1-1/4" UNC GR 8 ZINC	2
7	I2A-0616	HEX C/S 3/8-16 x 2 UNC GR 8	3
8	I2A-0812	HEX C/S 1/2-13 x 1-1/2 UNC GR 8	2
9	I3A-0810ZI	HEX C/S 1/2-20 x 1-1/4 UNF GR 8 ZINC	8
10	20540003	WELDMNT, TOP FEED	1
11	20540006	WELDMNT, FEED WHEEL	1
12	20540007	WELDMNT, FEED WHEEL BRKT	1
13	20640081	COVER, PVC, FEED WHEEL COUPLER, 6"	1
14	20A-08	NUT, HEX, 1/2-13 UNC GR 8	2
15	21240090	WASHER, FEED WHEEL COUPLER COVER MOUNT	1
16	30-06	LOCK WASHER, 3/8"	3
17	30A-06	LOCKWASHER, 3/8" USS GR 8	2
18	30A-08	LOCKWASHER 1/2"	8
19	31A-06	FLAT WASHER, 3/8 USS GRD 5	2
20	0150807	BUSHING, HARDENED, 1"	2
21	20540025	TUBING, FEED SLIDE	1
22	52F-08	SNAP RING, 1"	2

**NOTES:**

- ITEM #9 (13A-0810ZI) BOLTS TO BE TORQUED 95FT/LBS.
- ITEM #7 (12A-0616) BOLTS TO BE TORQUED 30FT/LBS.

FUNCTION GROUP	
<b>4 FEED SYSTEM</b>	
BUSINESS LINE	
<b>CHIPPERS</b>	
OWNER DOMAIN	
J.P. CARLTON COMPANY DIV. DAF INC.	
SERIAL NUMBERS	
IJ9UE021491167062	
DESCRIPTION	ISSUE
<b>TOP FEED ASSY</b>	<b>R1</b>

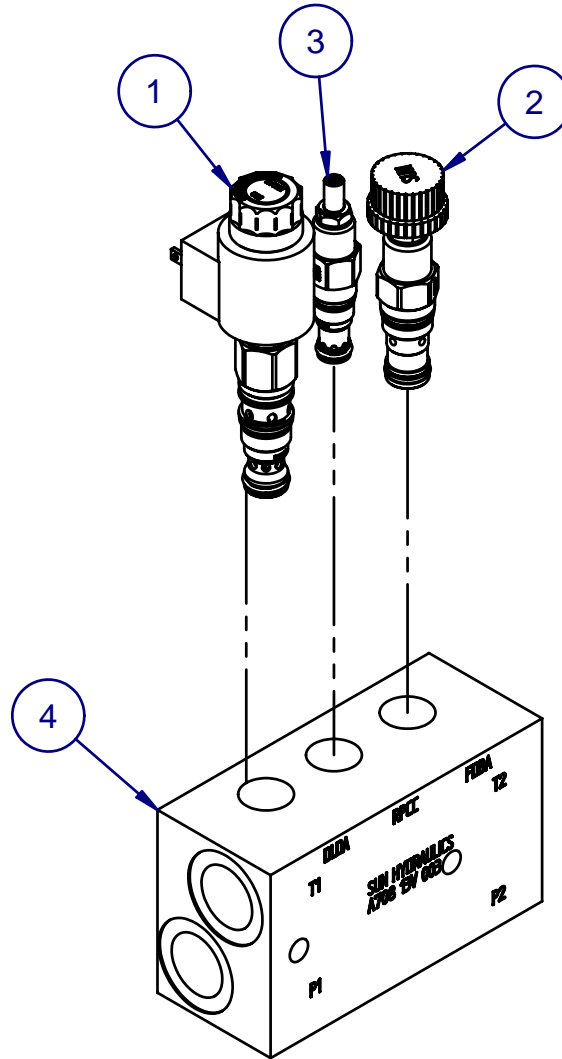

PART	ITEM	DESCRIPTION	QTY
1	0300121B	SOLENOID STOP VALVE	1
2	0300121C	VALVE,FULLY ADJUSTABLE PRESSURE COMENSATED FLOW CONTROL VAVE	1
3	0300121D	PISTON RELIEF VALVE- RPCC-LAN	1
4	0300173	AUTOFEED BODY 6" CHIPPER	1

FUNCTION GROUP	
<b>4 FEED SYSTEM</b>	
BUSINESS LINE	
<b>CHIPPERS</b>	
OWNER DOMAIN J.P. CARLTON COMPANY DIV. DAF INC.	
SERIAL NUMBERS 1J9UE021491167062	
DESCRIPTION	ISSUE
<b>AUTOFEED HYDRAULIC BLOCK</b>	<b>R1</b>

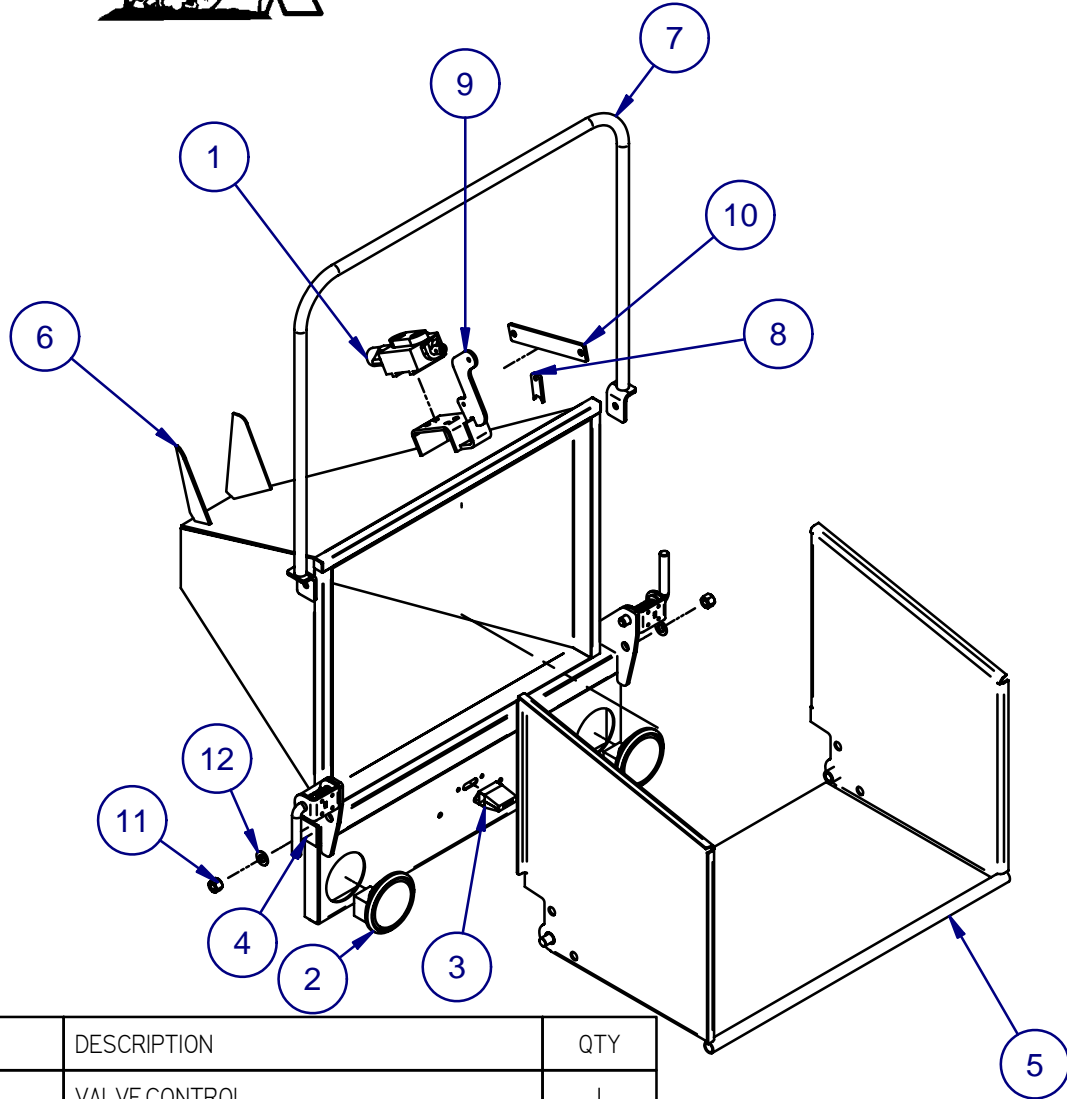

PART	ITEM	DESCRIPTION	QTY
1	0300035	VALVE,CONTROL	1
2	0350008A	STOP AND TAIL LIGHT	2
3	0350008B	TAG LIGHT	1
4	12A-1012	HEX C/S 5/8-11 x 1-1/2 UNC GR 8	2
5	20550002	WELDMENT,FOLDING END TABLE	1
6	20550003	WELDMENT,INFEED	1
7	20550005	WELDMENT,CONTROL BAR	1
8	20550024	MOUNT,FEED WHEEL CONTROL,LINKAGE	1
9	21250092	BRACKET,FEED WHEEL CONTROL LINKAGE	1
10	21250101	FLATBAR,CONTROL LINKAGE	1
11	29A-10	NUT,STOVER LOCK, 5/8-11 UNC GR8	2
12	31B-10Z1	FLAT WASHER 5/8 USS NARROW GR 8 Z&Y	2

FUNCTION GROUP	
<b>5 INFEED SYSTEM</b>	
BUSINESS LINE	
<b>CHIPPERS</b>	
OWNER DOMAIN J.P. CARLTON COMPANY DIV. DAF INC.	
SERIAL NUMBERS 1J9UE021491167062	
DESCRIPTION	ISSUE
<b>INFEED SYSTEM</b>	<b>R1</b>



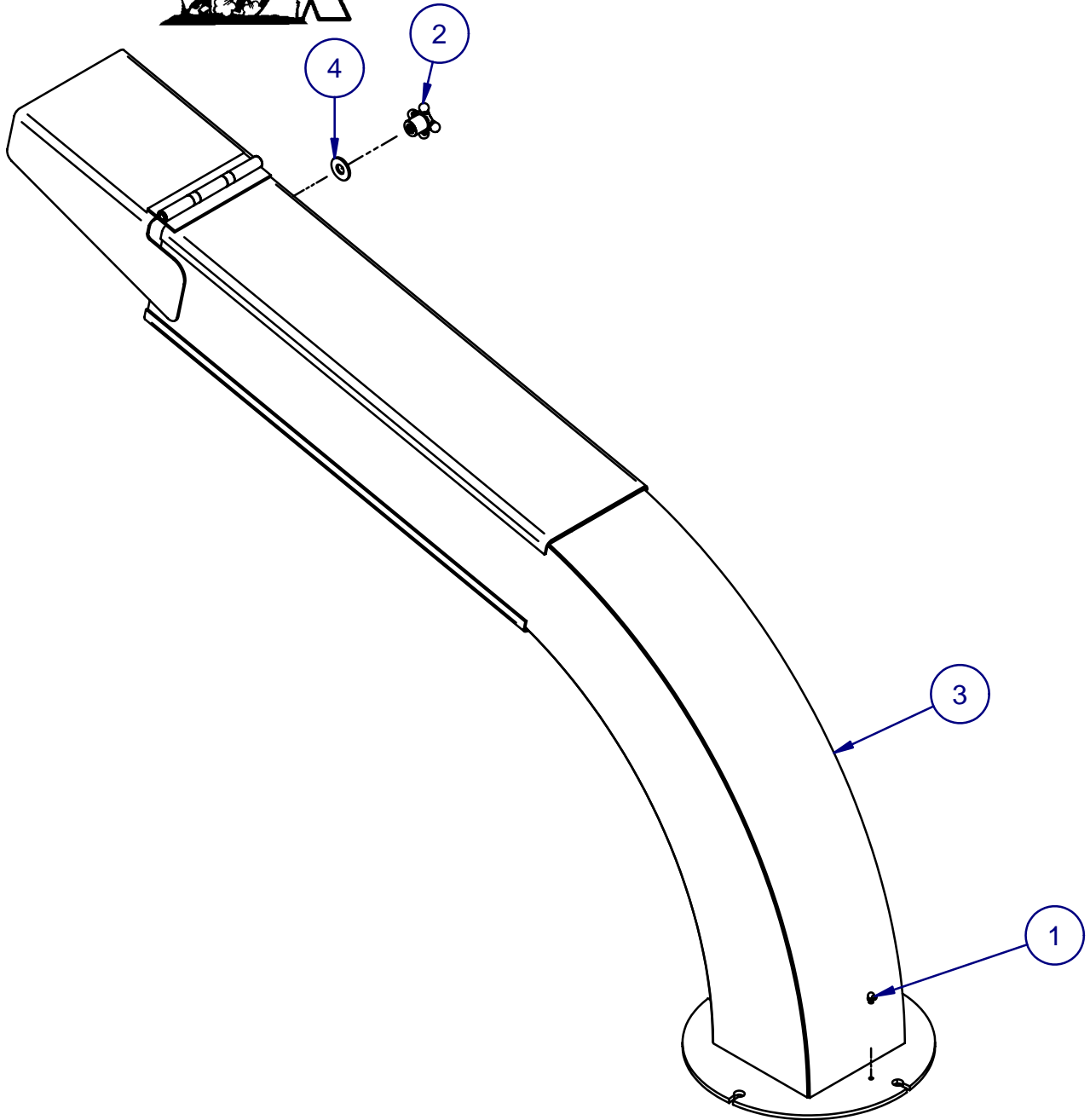

PART	ITEM	DESCRIPTION	QTY
1	0150616	GREASE FITTING 1/4-28 45 DEG	1
2	0150640	KNOB,DISCHARGE ADJUST	1
3	20560002	WELDMNT,DISCHARGE SYSTEM	1
4	31A-08ZI	FLAT WASHER 1/2 USS GR 8 Z&Y	1

FUNCTION GROUP	
<b>6 DISCHARGE SYSTEM</b>	
BUSINESS LINE	
<b>CHIPPERS</b>	
OWNER DOMAIN J.P. CARLTON COMPANY DIV. DAF INC.	
SERIAL NUMBERS 1J9UE021491167062	
DESCRIPTION	ISSUE
<b>DISCHARGE SYSTEM</b>	<b>R1</b>



## 1. Panel description and electrical pinout

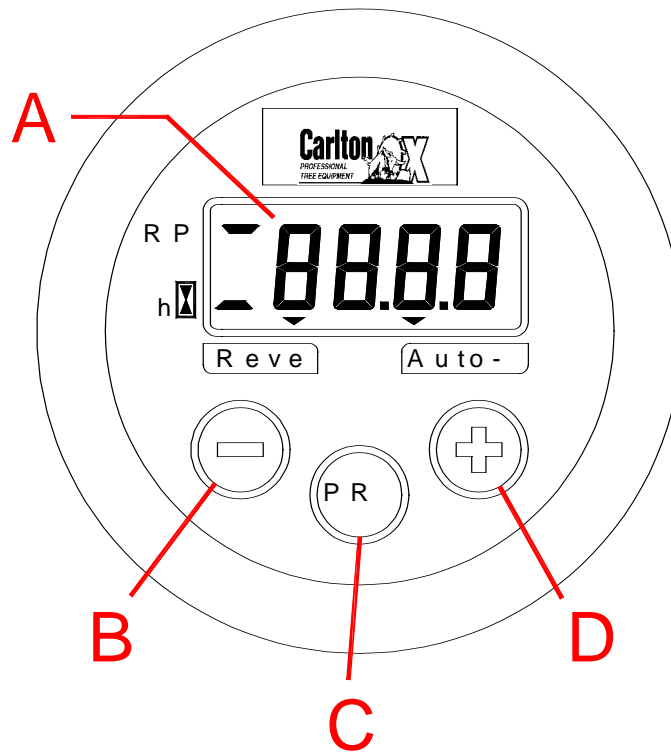

Ref.	Description	Signal type INput/OUTput	Pinout 4-way Delphi connector
A	Back-lit display for visualizing:		
	Heat engine RPM	IN (PNP NO, can be set to NPN) max. input frequency: 10KHz <sub>(1)</sub>	A
	Working hours	-	-
	“auto-feed” function ON	-	-
	“reverse” status ON	-	-
B	Setting key: it allows to decrease the value of the parameter being set	-	-
C	Setting key: to enter the parameters setting	-	-
	Positive output – EVS solenoid valve power supply	OUT (+V b*) 3A max	D
	Positive output – EVR solenoid valve power supply	OUT (+V b*) 3A max	Faston female single
	Positive input - monitor power supply <sub>(2)</sub>	IN (+Vb*)	C

	Ground input – monitor power supply	IN (GND)	B
--	-------------------------------------	----------	---

\*

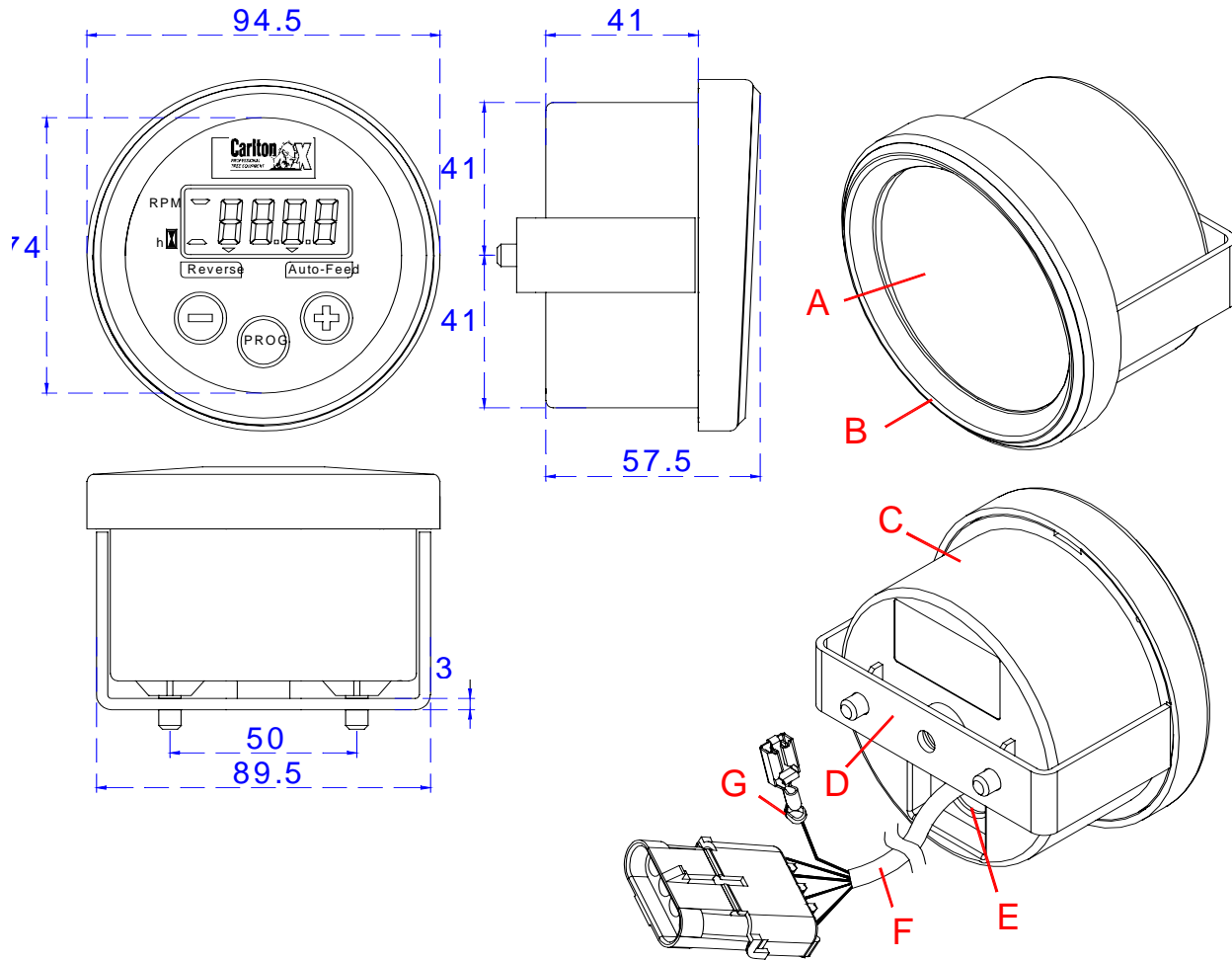

A	Silk-screened front panel in polyester
B	Front frame in black ABS
C	Housing in black ABS
D	Black metal supporting bracket
E	Black rubber fairlead-ring
F	Grey multipolar wiring $5 \times 0.75 \text{mm}^2$ , L = 250mm with 4-way Delphi connector, male contacts (cod. 12010974).
G	Wiring for EVR solenoid valve, with single female faston connector AMP cod. 160759-3 or 160773-3

## 2. Operating

After turning on the monitor, a 2 seconds test is automatically carried out: all display segments are on; after such a test, working hours are displayed for about 3 seconds, then engine RPMs are displayed and the other display indicators show the working status:

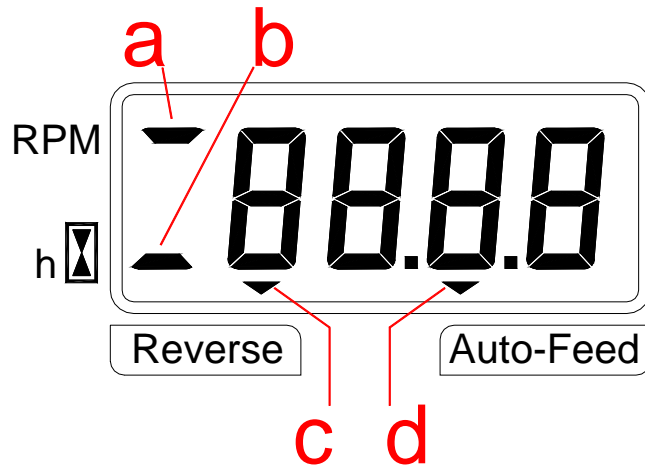

**Picture A**

- a) if ON, engine RPMs are displayed;
- b) if ON, working hours are displayed;
- c) if ON, reverse phase is currently ongoing (emergency condition)
- d) if ON, "auto-feed" procedure is currently ongoing (emergency condition).

During standard operation the monitor detects engine RPMs. In case they go below the minimum programmed value, the monitor enables one of the emergency procedures listed below. All emergency procedures are back off, after the RPMs are restored over the maximum programmed value. The monitor is now back in standard working condition.

Emergency procedures are different depending on the "type" parameter programmed.



### 3. Emergency procedure "type 0"

This procedure is applied on those machines only where the ACTIVATION of the solenoid valves allows to protect the engine against excessive stress.

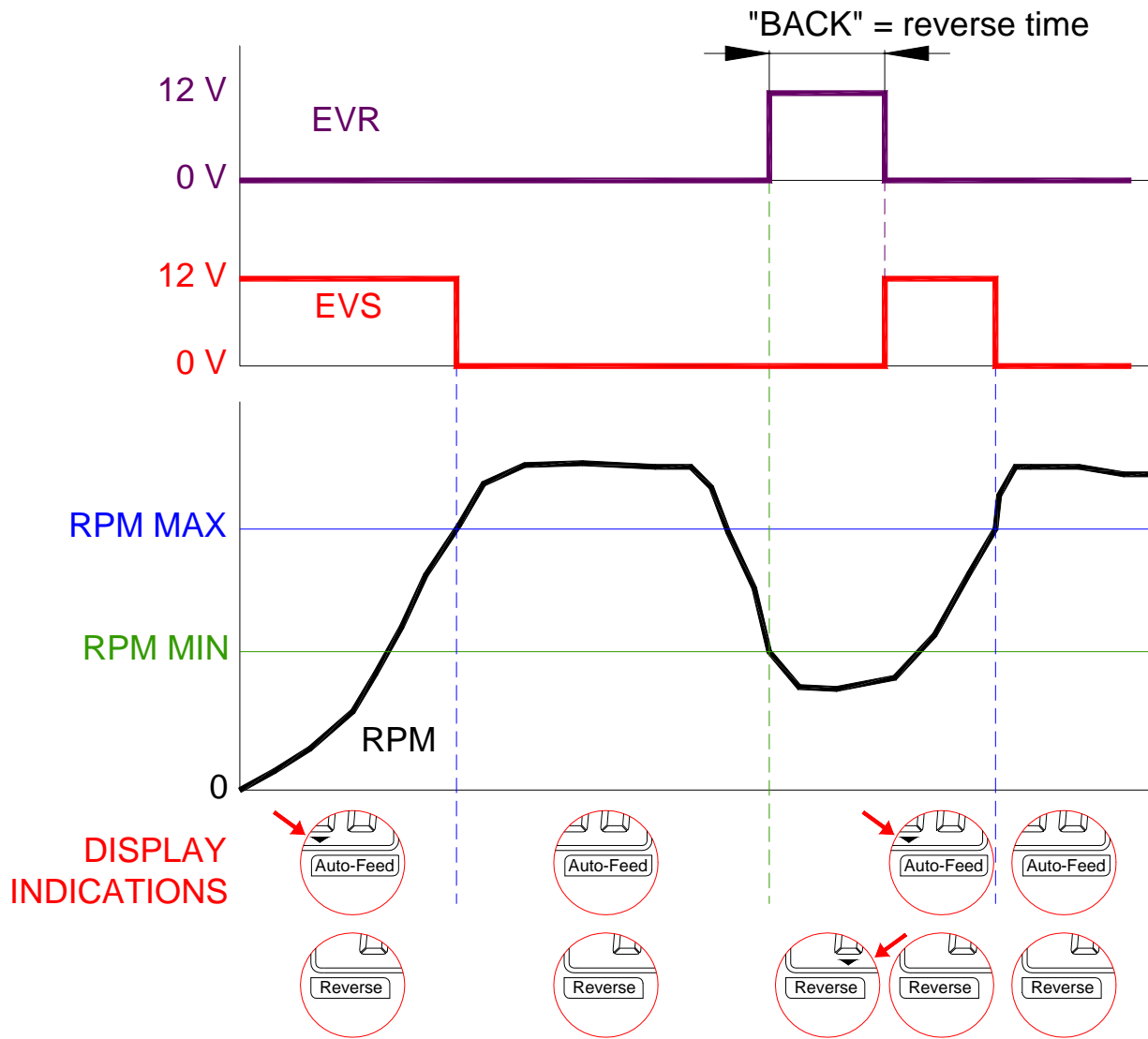

#### 4. Emergency procedure "type 1"

This procedure is applied on those machines only where the DE-ACTIVATION of the solenoid valves allows to protect the engine against excessive stress.

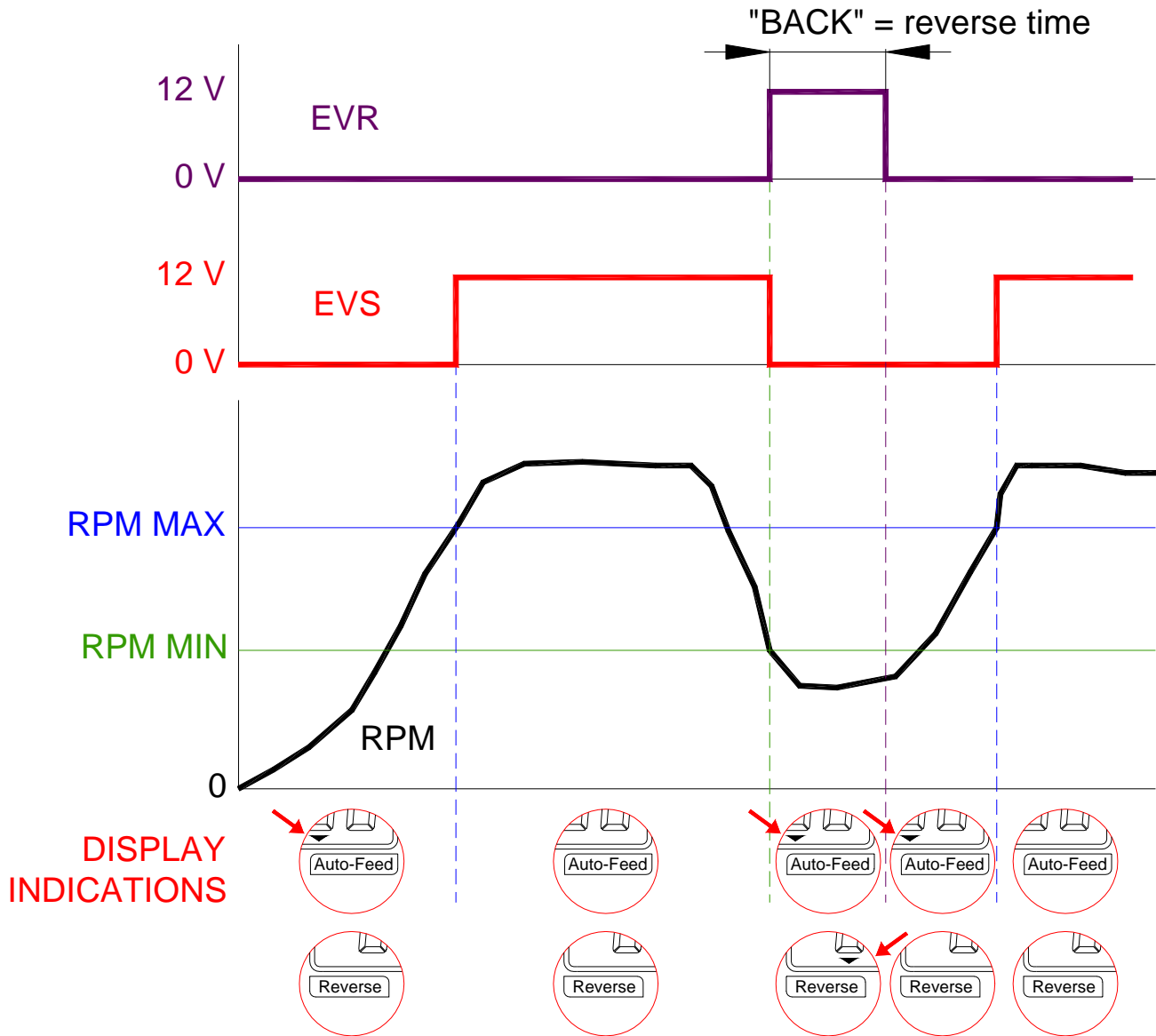

In case RPMs exceed the RPM maximum value during the reverse interval (back), the activation sequence shall be as shown below:

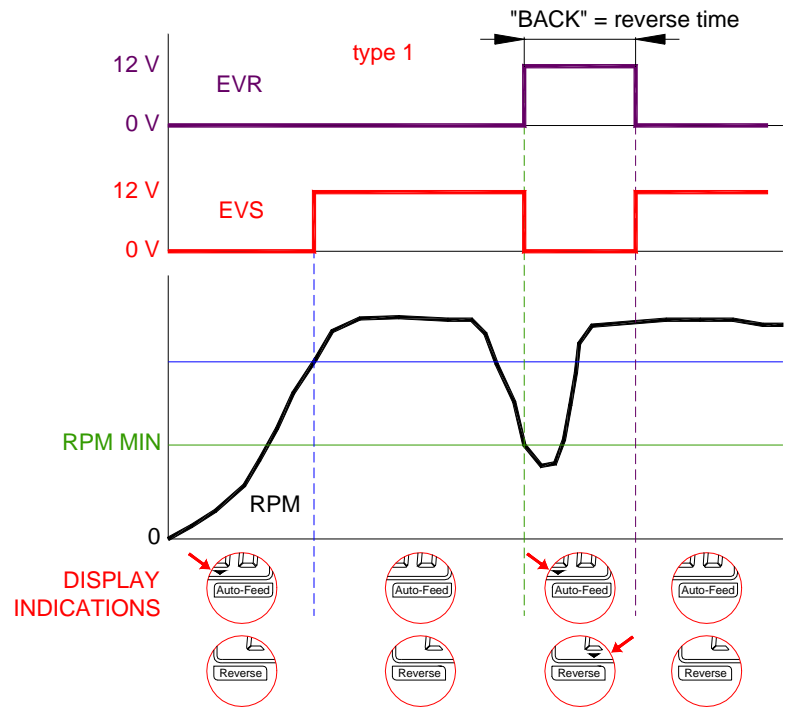
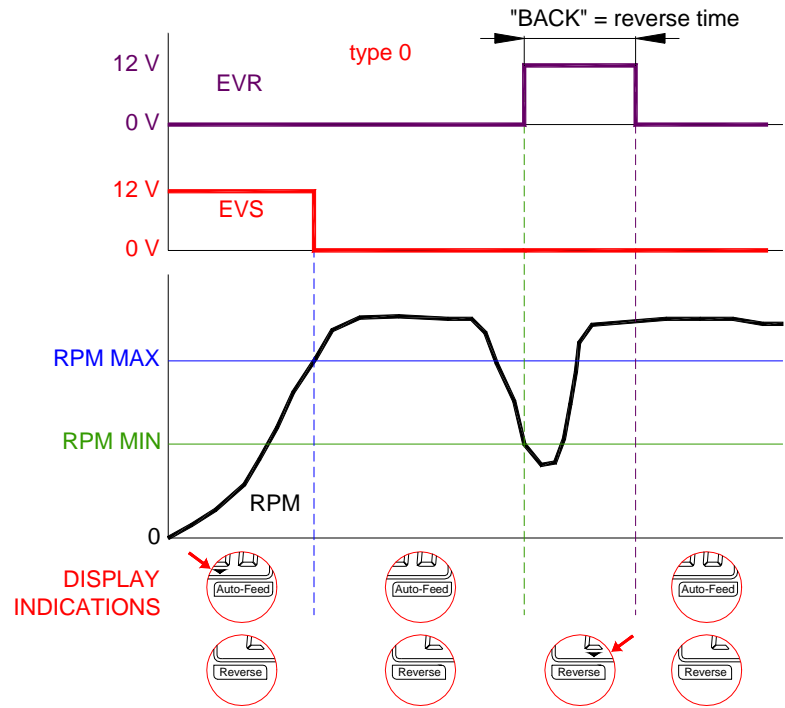

During operation, working hours can always be displayed by switching for a BRIEF INTERVAL key (+) or (-). The display shows now the ref. indicator “b” on page 7 and working hours are displayed for 3 seconds. During this interval the EVS solenoid valve is energized or de-energized by the monitor (according to what programmed in “type” parameter) only if the “auto-feed” function has been enabled (see chapter 5.3), whereas the EVR solenoid valve is never energized.

### 5. Range of parameters displayed

Description	Range
Engine RPMe	0 ÷ 9990 steps of 10 RPMs
Working hours	0.0 ÷ 999.9 hours, steps of 0.1 hour ( 6 minutes ); once 999.9 are reached, then steps of 1 hour until 9999 hours. <b>Working hours increase only if RPMs &gt; 500.</b>

### 6. Setting

The device has two setting phases: “user” setting and "manufacturer" setting. Both programming phases can be carried out with the engine operating (RPMs > 500). The operator shall complete the procedure for each phase by confirming all parameters at a time to allow all modified parameters are stored. Otherwise, if the operator is within one programming phase and no key is selected for an interval of 7 seconds, the monitor quits the phase WITHOUT storing any executed changes.

The “user” phase permits programming of the following parameters:

- Minimum value for RPMs
- Maximum value for RPMs
- Machine type selection (with or without reverse)
- Reverse time (not used if the reverse valve is not present).

The “manufacturer” setting allows programming of the following parameter:

- Pulses/revolution for engine RPMs counting (Set By Factory)

NOTES: the parameter value is kept displayed during each programming phase; the parameter name is displayed only while going from one parameter to the next one or when keys + (plus) and (-) minus are simultaneously pressed.

For safety purposes, the EVS solenoid valve is energized or de-energized (according to what programmed in “type” parameter) by the monitor each time a programming phase is entered only if the “auto-feed” function has been enabled (see par. 5.3), whereas the EVR solenoid valve is never energized.

## 7. "User" setting

To enter the "user" programming phase, with the monitor ON keep key PROG pressed for at least 2 seconds and until the first parameter "HI" (i.e. RPMs minimum permitted value) is displayed. After an interval of 1 second the current programmed value is displayed (es. 4800RPM).

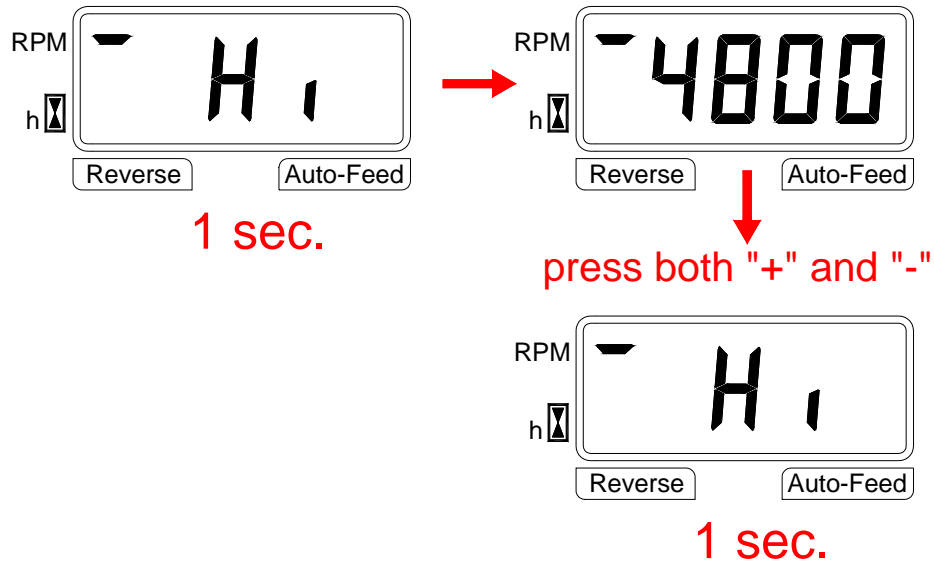

The parameter is changed by using key "+" or "-"; switching key "PROG" allows to go to next parameter "LO" (i.e. RPMs minimum permitted value). It is displayed with same procedure.

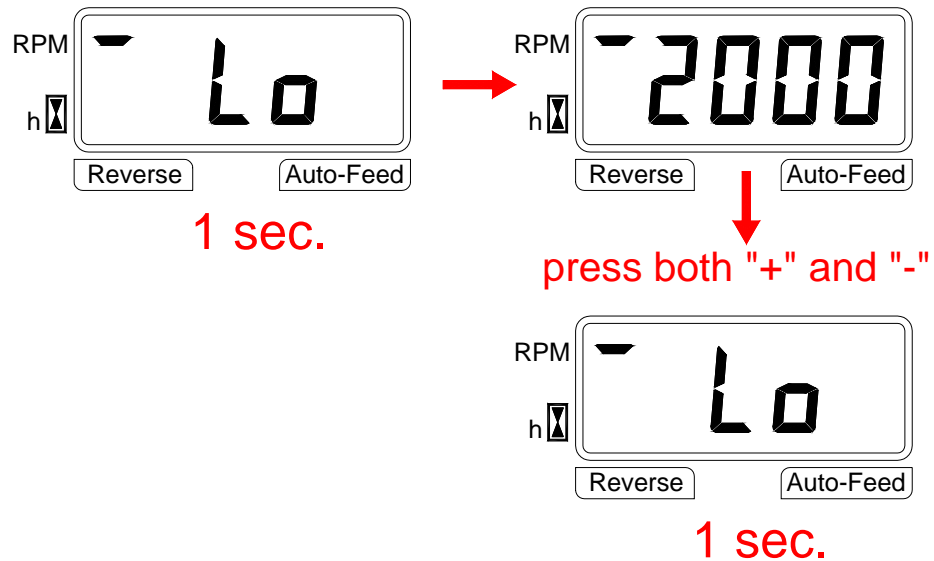

The parameter is changed by using key "+" or "-"; switching key "PROG" allows to go to next parameter "TYPE" (i.e. machine with reverse solenoid valve or without reverse valve). It is displayed with same procedure.

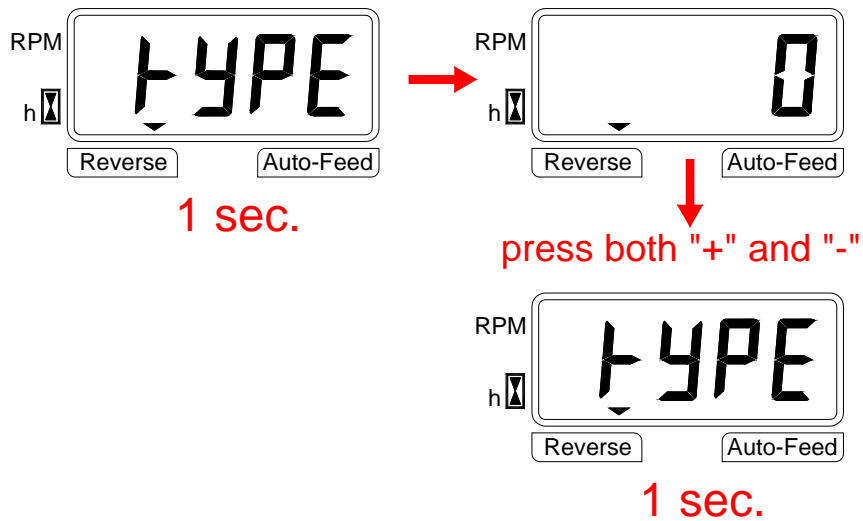

The parameter is changed by using key “+” or “-”; switching key “PROG” allows to go to next parameter “BACK” (i.e. activation time of the reverse solenoid valve, in ms). It is displayed with same procedure.

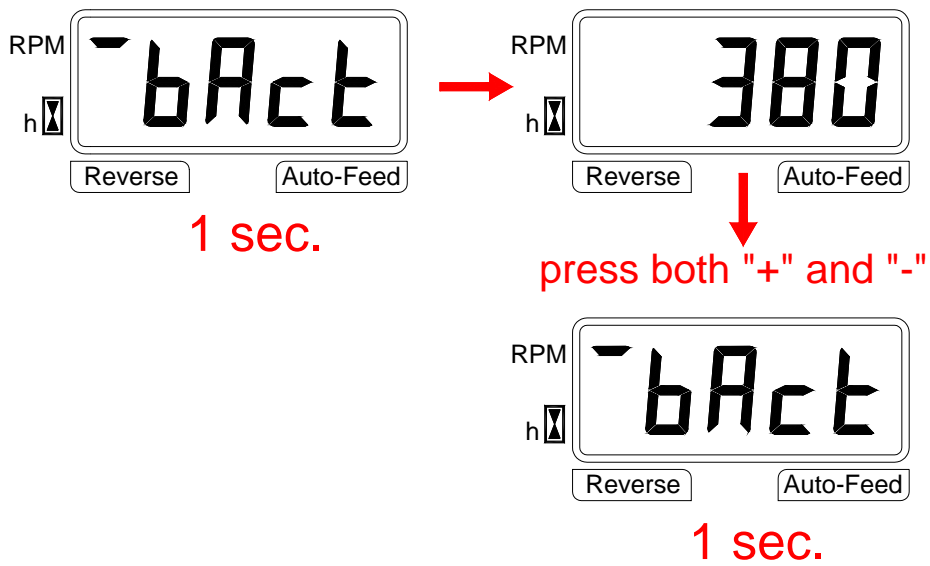

The parameter is changed by using key “+” or “-”; switching key “PROG” allows to store all data entered and quit setting - the display will show for 1 second following indication:





## How to activate and de-activate the “auto-feed” function

The device has a further programming phase, meant for activating and de-activating the “auto-feed” function. This function includes the emergency procedures previously described.

NOTE: when the “auto-feed” function is de-activated, the monitor features exclusively revolution counter function and hours counter function; the reverse solenoid valve EVR is always de-energized and the EVS safety valve can be de-energized (if “type 0” operation type is selected) or energized (if “type 1” operation type is selected). The monitor is supplied as a standard with the “auto-feed” function enabled; in fact, when the monitor is switched-on with engine off (RPM =0), the ref. indicator "d" picture "A" pag. 7 is on.

Press key (-) minus for at least 3 seconds to de-activate the “auto-feed” function and until the sequence below is displayed:



Once the sequence has been completed, engine RPMs are displayed but the ref. indicator "d" picture "A" page 7 is off; to activate again the “auto-feed” function press key (+) plus for at least 3 seconds until the sequence below is displayed:



Once the sequence has been completed, engine RPMs are displayed and the ref. indicator "d" picture "A" page 7 is on.

## 8. Range of programmable parameters

Description	Programmable range	Default values
LOW (Minimum RPM value permitted)	500 ÷ 2700 (*) RPM, steps 10RPM	2240
HIGH (Maximum RPM value permitted)	2000(*) ÷ 5000 RPM, steps 10RPM	2440
BACK (reaction time for reverse valve)	0 ÷ 2500ms, steps 10ms	300
PULSES (number of pulses/revolution for RPM)	2.0 ÷ 200.0 pulse/rev, steps 0.1 pulse/rev	129.0
TYPE (reverse function is ON)	ON or OFF	ON

(\*) LOW value shall never exceed HIGH value (and vice versa), and priority shall be given to the LOW value with 20RPMs hysteresis; e.g: if a LOW value is programmed equal to 1980RPM, the HIGH value shall not be lower than 2000RPM;

Now, by releasing all keys, the monitor operates under standard condition and the initial test is carried out again.

## 7. Technical features

Supply voltage	10 ÷ 16 Vdc
Max. current absorption at 16 Vdc (excluding outputs)	200 mA
Protection degree	IP 66
Operating temperature range	-20 / +70 °C
Storage temperature range	-25 / +85 °C
Mechanical vibrations resistance	2 g random
Reference standards for the project	MC14982

### ***Autofeed Settings for Carlton Chippers***

Engine Make	Engine Model	HP Rating	High Setting	Low Setting	CAL
Vanguard	Big Block V Twin	35 HP	3360	3060	98
Kubota	D1105T	33 HP	2300	2000	12
Kohler	CH740	27HP	3330	2900	97.4
Kubota	V3300T	88 HP	2300	2150	12
Kubota	V3800T	99HP	2300	2150	12
John Deere		99 HP	2440	2240	129
John Deere		140 HP	2440	2240	129
John Deere	6068T	173 HP	2440	2370	129
John Deere	6068H	250 HP	2440	2370	129
John Deere III		140 HP	2200	2000	129
John Deere III	6068T	173 HP	2200	2000	129
John Deere III	6068H	250 HP	2200	2000	129



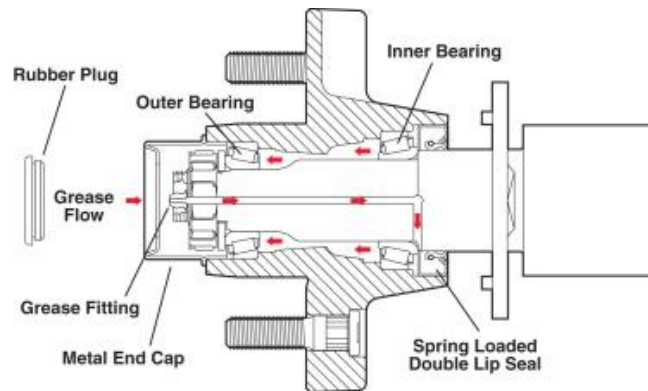
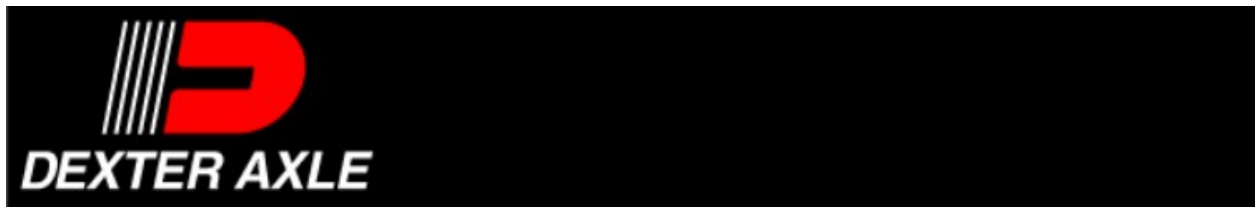

Axles equipped with Dexter's E-Z Lube feature can be periodically lubricated without removing the hubs from the axle. This feature consists of axle spindles that have been specially drilled and assembled with grease fittings in their ends. When grease is pumped into the fitting, it is channeled to the inner bearing and then flows back to the outer bearing and eventually back out the grease cap hole.

1. Remove the rubber plug from the end of the grease cap.
2. Place a standard grease gun onto the grease fitting located in the end of the spindle. Make sure the grease gun nozzle is fully engaged on the fitting.
3. Pump grease into the grease fitting. The old, displaced grease will begin to flow back out the cap around the grease gun nozzle.
4. When the new, clean grease is observed, remove the grease gun, wipe off any excess, and replace the rubber plug in the cap.

The E-Z Lube feature is designed to allow immersion in water. Axles not equipped with E-Z Lube are not designed for immersion and bearings should be repacked after each immersion. If hubs are removed from an axle with an E-Z Lube feature, it is imperative that the seals be replaced before bearing lubrication. Otherwise, the chance of grease getting on brake linings is greatly increased.

NOTE: The convenient lubrication provisions of the E-Z Lube must not replace periodic inspection of the bearings.



## CAUTION

Do not mix Lithium, calcium, sodium or barium complex greases due to possible compatibility problems. When changing from one type of grease to another, it is necessary to insure all the old grease has been removed.

If your axles are equipped with oil-lubricated hubs, then your lubrication procedure is to periodically fill the hub with high quality hypoid gear oil to the level indicated on the clear plastic oil cap. The oil can be filled through the rubber plug hole in the cap.

### Recommended Wheel Bearing Lubrication Specifications

#### Grease:

Thickener Type .....	Lithium Complex
Dropping Point .....	230°C (446°F) minimum
Consistency .....	NLGI No. 2
Additives .....	EP, Corrosion & Oxidation Inhibitors
Base Oil .....	Solvent Refined Petroleum Oil
Base Oil Viscosity .....	@40°C (104°F) 150cSt(695 SUS) Min.
Viscosity Index .....	80 Minimum
Pour Point .....	-10°C (14°F) Minimum

#### Approved Sources:

Mobil Oil .....	Mobilgrease HP
Exxon/Standard .....	Ronex MP
Kendall Refining Co. ....	Kendall L-427
Ashland Oil Co. ....	Valvoline Val-plex EP Grease
Pennzoil Prod. Co. ....	Premium Wheel Bearing Grease 707L

#### Oil:

SAE 90 Hypoid Gear (Hypoid Rear Axle Oil)  
Use only with hubs equipped with oil option.

#### Approved Sources:

Union Oil Co. ....	Union MP, Gearlube - LS
Exxon Co. USA .....	Gear Oil GX 80W-90
Mobil Oil Corp.. ....	Mobilube SHC 75W-90
Pennzoil Prod. Co. ....	Multipurpose Gear Lubricant 4092,
.....	Multipurpose Gear Lubricant 4096



## Maintenance Schedule

Item	Function Required	Weekly	3 Months or 3000 Miles	6 Months or 6000 Miles	12 Months or 12000 Miles
Brakes	Test that they are operational.	<i>At Every Use</i>			
Brake Adjustment	Adjust to proper operating clearance.		●		
Brake Magnets	Inspect for wear and current draw.			●	
Brake Linings	Inspect for wear or contamination.				●
Brake Controller	Check for correct amperage & modulation.			●	
Brake Cylinders	Check for leaks, sticking.				●
Brake Lines	Inspect for cracks, leaks, kinks.				●
Camshaft Bushings	Check for wear and breakage.			●	
Anchor Pins & Rollers	Lubricate with approved grease.			●	
Slack Adjuster Lubrication	Lubricate with approved grease.			●	
Trailer Brake Wiring	Inspect wiring for bare spots, fray, etc.				●
Breakaway System	Check battery charge and switch operation.	<i>At Every Use</i>			
Hub/Drum	Inspect for abnormal wear or scoring.				●
Wheel Bearing & Cups	Inspect for corrosion or wear. Clean & repack..				●
Seals	Inspect for leakage. Replace if removed.				●
Springs	Inspect for wear, loss of arch.				●
Suspension Parts	Inspect for bending, loose fasteners, wear.			●	
Hangers	Inspect Welds.				●
Wheel Nuts and Bolts	Tighten to specified torque values.		●		
Wheels	Inspect for cracks, dents or distortion.			●	
Tire Inflation Pressure	Inflate tires to mfg's. specifications.	●			
Tire Condition	Inspect for cuts, wear, bulging, etc.		●		



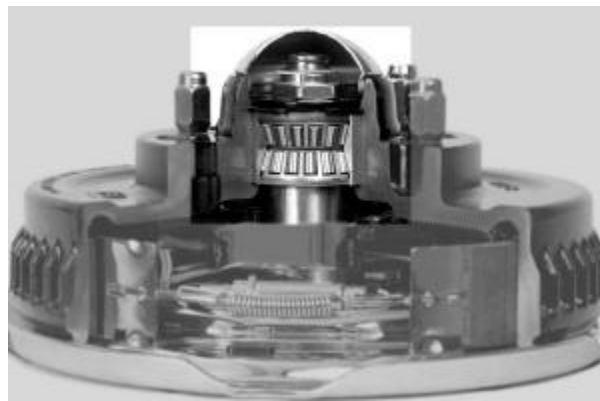

## Product Features

- No need to pull the hubs to repack the bearings OR replace the seals when checking the brakes.
- Pre-set adjustment means installation is easy and human error is virtually eliminated in bearing adjustment.
- Pre-lubricated at the bearing factory providing resistance to contamination.
- Sealed for life, which means increased durability and reliability and no more bearing maintenance.
- 5 year or 100,000 mile warranty against defects in material and workmanship.

# OWNER'S MANUAL

## **KOHLER** COMMAND CH18-26, CH730-750 HORIZONTAL CRANKSHAFT



**KOHLER**  
ENGINES

## Safety Precautions

To ensure safe operations please read the following statements and understand their meaning. Also refer to your equipment owner's manual for other important safety information. This manual contains safety precautions which are explained below. Please read carefully.

### **WARNING**

Warning is used to indicate the presence of a hazard that *can* cause *severe* personal injury, death, or substantial property damage if the warning is ignored.

### **CAUTION**



Caution is used to indicate the presence of a hazard that *will* or *can* cause *minor* personal injury or property damage if the caution is ignored.

### **NOTE**

Note is used to notify people of installation, operation, or maintenance information that is important but not hazard-related.



### **For Your Safety!**

*These precautions should be followed at all times. Failure to follow these precautions could result in injury to yourself and others.*

 <b>WARNING</b>

<b>Explosive Fuel can cause fires and severe burns.</b>
Do not fill the fuel tank while the engine is hot or running.



#### **Explosive Fuel!**

*Gasoline is extremely flammable and its vapors can explode if ignited. Store gasoline only in approved containers, in well ventilated, unoccupied buildings, away from sparks or flames. Do not fill the fuel tank while the engine is hot or running, since spilled fuel could ignite if it comes in contact with hot parts or sparks from ignition. Do not start the engine near spilled fuel. Never use gasoline as a cleaning agent.*

 <b>WARNING</b>

<b>Rotating Parts can cause severe injury.</b>
Stay away while engine is in operation.



#### **Rotating Parts!**

*Keep hands, feet, hair, and clothing away from all moving parts to prevent injury. Never operate the engine with covers, shrouds, or guards removed.*

 <b>WARNING</b>

<b>Hot Parts can cause severe burns.</b>
Do not touch engine while operating or just after stopping.

#### **Hot Parts!**

*Engine components can get extremely hot from operation. To prevent severe burns, do not touch these areas while the engine is running, or immediately after it is turned off. Never operate the engine with heat shields or guards removed.*

 <b>CAUTION</b>

<b>Electrical Shock can cause injury.</b>
Do not touch wires while engine is running.

#### **Electrical Shock!**

*Never touch electrical wires or components while the engine is running. They can be sources of electrical shock.*

<b>California Proposition 65 Warning</b>
<i>Engine exhaust from this product contains chemicals known to the State of California to cause cancer, birth defects, or other reproductive harm.</i>



## Safety Precautions (Cont.)

 <b>WARNING</b>

<b>Accidental Starts can cause severe injury or death.</b>  Disconnect and ground spark plug leads before servicing.



### Accidental Starts!

*Disabling engine. Accidental starting can cause severe injury or death. Before working on the engine or equipment, disable the engine as follows: 1) Disconnect the spark plug lead(s). 2) Disconnect negative (-) battery cable from battery.*

 <b>WARNING</b>

<b>Carbon Monoxide can cause severe nausea, fainting or death.</b>  Avoid inhaling exhaust fumes, and never run the engine in a closed building or confined area.

### Lethal Exhaust Gases!

*Engine exhaust gases contain poisonous carbon monoxide. Carbon monoxide is odorless, colorless, and can cause death if inhaled. Avoid inhaling exhaust fumes, and never run the engine in a closed building or confined area.*

 <b>WARNING</b>

<b>Explosive Gas can cause fires and severe acid burns.</b>  Charge battery only in a well ventilated area. Keep sources of ignition away.

### Explosive Gas!

*Batteries produce explosive hydrogen gas while being charged. To prevent a fire or explosion, charge batteries only in well ventilated areas. Keep sparks, open flames, and other sources of ignition away from the battery at all times. Keep batteries out of the reach of children. Remove all jewelry when servicing batteries.*

*Before disconnecting the negative (-) ground cable, make sure all switches are OFF. If ON, a spark will occur at the ground cable terminal which could cause an explosion if hydrogen gas or gasoline vapors are present.*

**Congratulations** – You have selected a fine four-cycle, twin cylinder, air-cooled engine. Kohler designs long life strength and on-the-job durability into each engine...making a Kohler engine dependable...dependability you can count on. Here are some reasons why:

- Efficient overhead valve design and full pressure lubrication provide maximum power, torque, and reliability under all operating conditions.
- Dependable, maintenance-free electronic ignition ensures fast, easy starts time after time.
- Kohler engines are easy to service. All routine service areas like the dipstick, oil fill, air cleaner, and spark plugs are easily and quickly accessible.
- Parts subject to the most wear and tear (like the cylinder liner\* and camshaft) are made from precision formulated cast iron. Because the cylinder liner\* can be rebored, these engines can last even longer.

\*Some CH25/26 engines have POWER-BORE™ Cylinders. These cylinders are plated with nickel-silicon to give increased power, virtually permanent cylinder life, superior oil control, and reduced exhaust emissions. These cylinders cannot be rebored.

- Every Kohler engine is backed by a worldwide network of over 10,000 distributors and dealers. Service support is just a phone call away. Call 1-800-544-2444 (U.S. & Canada) for Sales & Service assistance.

To keep your engine in top operating condition, follow the maintenance procedures in this manual.

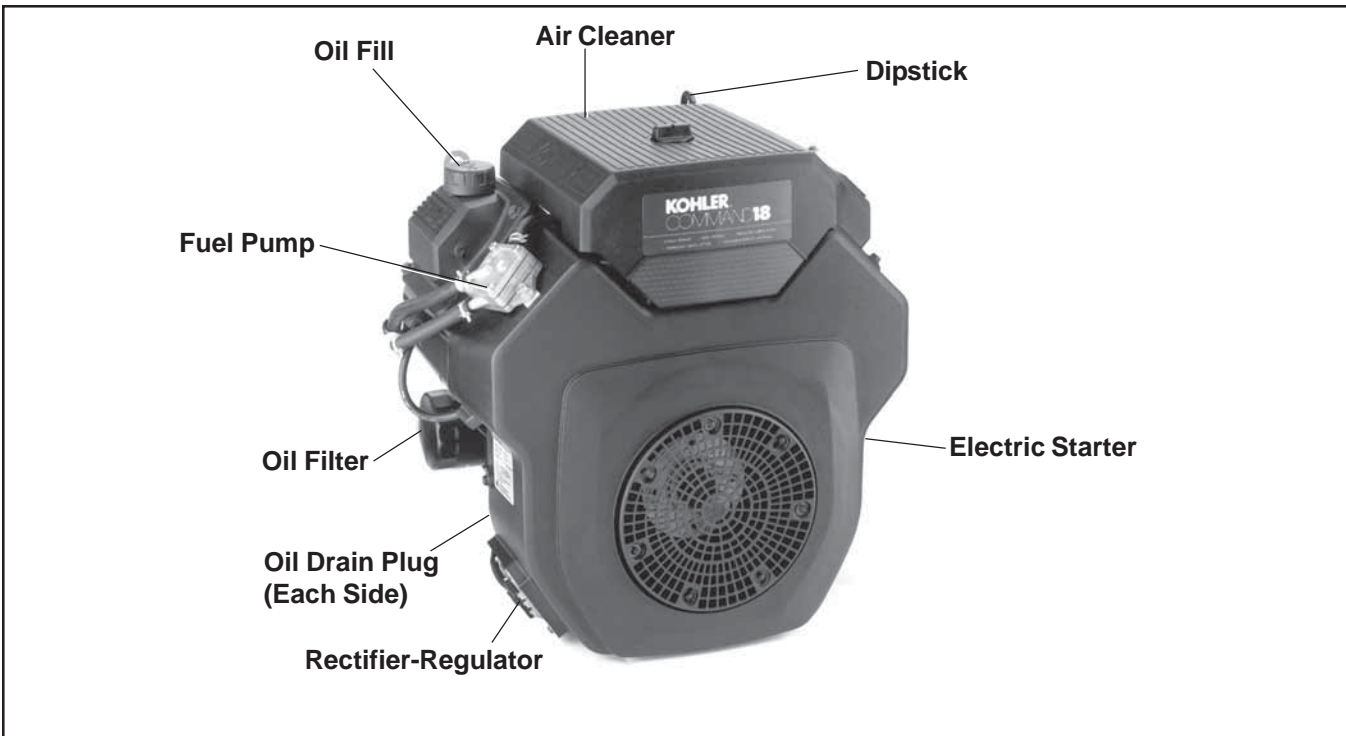

Figure 1. Typical Command Horizontal Shaft Carbureted Engine.

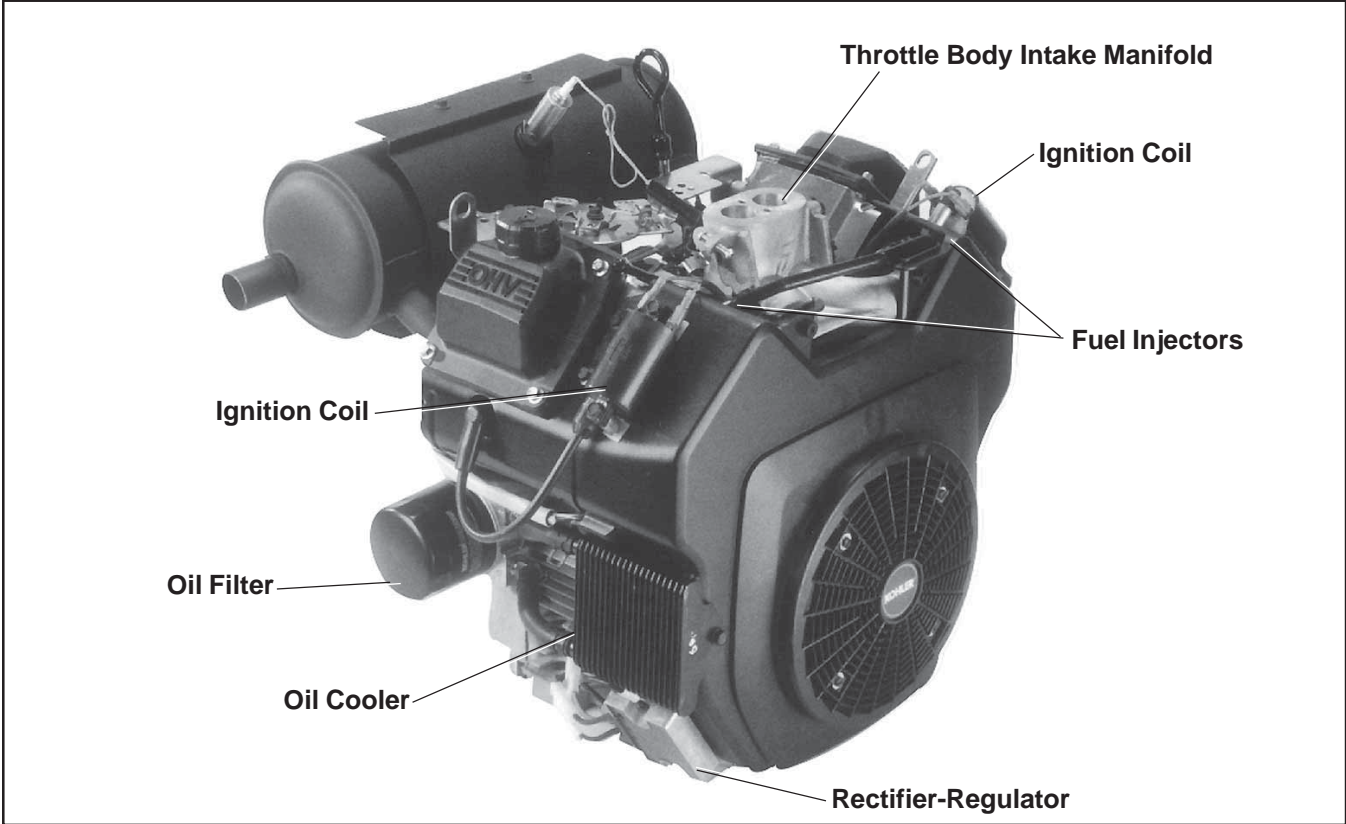

Figure 2. Typical Command Horizontal Shaft EFI Engine.



## Oil Recommendations

Using the proper type and weight of oil in the crankcase is extremely important. So is checking oil daily and changing oil regularly. Failure to use the correct oil, or using dirty oil, causes premature engine wear and failure.

### Oil Type

Use high quality detergent oil of **API (American Petroleum Institute) service class SG, SH, SJ, or higher**. Select the viscosity based on the air temperature at the time of operation as shown in the following table.

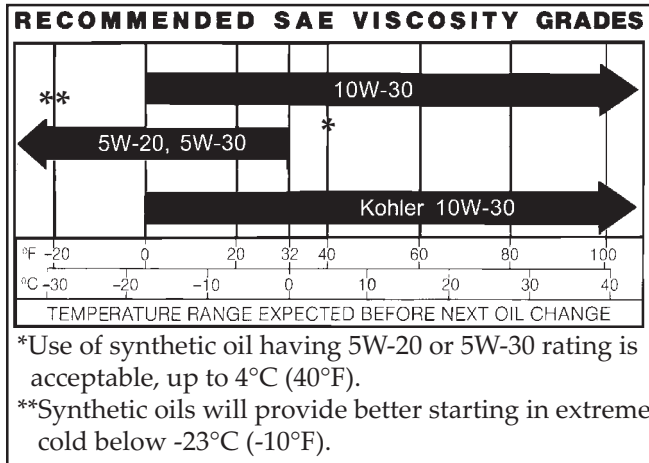

Figure 3. Viscosity Grades Table.

NOTE: Using other than service class SG, SH, SJ or higher oil or extending oil change intervals longer than recommended can cause engine damage.

NOTE: Synthetic oils meeting the listed classifications may be used with oil changes performed at the recommended intervals. However to allow piston rings to properly seat, a new or rebuilt engine should be operated for at least 50 hours using standard petroleum based oil before switching to synthetic oil.

A logo or symbol on oil containers identifies the API service class and SAE viscosity grade. See Figure 4.



Figure 4. Oil Container Logo.

Refer to Maintenance Instructions beginning on page 8 for detailed oil check, oil change, and oil filter change procedures.

## Fuel Recommendations



### WARNING: Explosive Fuel!

Gasoline is extremely flammable and its vapors can explode if ignited. Store gasoline only in approved containers, in well ventilated, unoccupied buildings, away from sparks or flames. Do not fill the fuel tank while the engine is hot or running, since spilled fuel could ignite if it comes in contact with hot parts or sparks from ignition. Do not start the engine near spilled fuel. Never use gasoline as a cleaning agent.

## General Recommendations

Purchase gasoline in small quantities and store in clean, approved containers. A container with a capacity of 2 gallons or less with a pouring spout is recommended. Such a container is easier to handle and helps eliminate spillage during refueling.

Do not use gasoline left over from the previous season, to minimize gum deposits in fuel system and to ensure easy starting.

Do not add oil to the gasoline.

Do not overfill the fuel tank. Leave room for the fuel to expand.

## Fuel Type

For best results use only clean, fresh, **unleaded** gasoline with a pump sticker octane rating of 87 or higher. In countries using the Research method, it should be 90 octane minimum.

Unleaded gasoline is recommended as it leaves less combustion chamber deposits and reduces harmful exhaust emissions. Leaded gasoline is not recommended and **must not** be used on EFI engines, or on other models where exhaust emissions are regulated.

## Gasoline/Alcohol blends

Gasohol (up to 10% ethyl alcohol, 90% unleaded gasoline by volume) is approved as a fuel for Kohler engines. Other gasoline/alcohol blends including E20 and E85 are not to be used and not approved. Any failures resulting from use of these fuels will not be warranted.

## Gasoline/Ether blends

Methyl Tertiary Butyl Ether (MTBE) and unleaded gasoline blends (up to a maximum of 15% MTBE by volume) are approved as a fuel for Kohler engines. Other gasoline/ether blends are not approved.



## Engine Identification Numbers

When ordering parts, or in any communication involving an engine, always give the **Model, Specification, and Serial Numbers** of the engine.

The engine identification numbers appear on a decal affixed to the engine shrouding. Include letter suffixes, if there are any.

Record your engine identification numbers on the identification label below (Figure 5) for future reference.

**For Models CH18-745**

**KOHLER**

**IMPORTANT ENGINE INFORMATION**  
THIS ENGINE MEETS U.S. EPA AND CA 2005 AND LATER AND EC STAGE II (SN:4) EMISSION REGS FOR SI SMALL OFF-ROAD ENGINES

**FAMILY**  
**TYPE APP**  
**DISPL. (CC)**  
**MODEL NO.**  
**SPEC. NO.** N11236  
**SERIAL NO.**  
**BUILD DATE**  
**OEM PROD. NO.**

EMISSION COMPLIANCE PERIOD:  
EPA:                      CARB:  
CERTIFIED ON:  
REFER TO OWNER'S MANUAL FOR HP RATING, SAFETY, MAINTENANCE AND ADJUSTMENTS  
1-800-544-2444    www.kohlerengines.com  
KOHLER CO. KOHLER, WISCONSIN USA

**For Model CH750**

**KOHLER**

**IMPORTANT ENGINE INFORMATION**  
THIS ENGINE MEETS EMISSION REGS FOR U.S. EPA 2005 AND LATER AND EC STAGE II (SN:4) SI SMALL OFF-ROAD ENGINES AND CA 2005 AND LATER LSI ENGINES

**FAMILY**  
**TYPE APP**  
**DISPL. (CC)**  
**MODEL NO.**  
**SPEC. NO.**  
**SERIAL NO.**  
**BUILD DATE**  
**OEM PROD. NO.**

EMISSION COMPLIANCE PERIOD:  
EPA:                      CARB:  
CERTIFIED ON:  
REFER TO OWNER'S MANUAL FOR HP RATING, SAFETY, MAINTENANCE AND ADJUSTMENTS  
1-800-544-2444    www.kohlerengines.com  
KOHLER CO. KOHLER, WISCONSIN USA

Figure 5. Engine Identification Label.

The Emission Compliance Period referred to on the Emission Control or Air Index label indicates the number of operating hours for which the engine has been shown to meet Federal and CARB emission requirements. The following table provides the Engine Compliance Period (in hours) associated with the category descriptor found on the certification label.

### Emission Compliance Period (Hours)

EPA	Category C 250 hours	Category B 500 hours	Category A 1000 hours
CARB	Moderate 125 hours	Intermediate 250 hours	Extended 500* hours

\*Extended hours for Model CH750 is 1000.

Refer to certification label for engine displacement.

Exhaust Emission Control System for models CH18,20,22,23,730,740,750 is EM. Exhaust Emission Control System for models CH26 and CH745 are EM, O2S, ECM, MFI.

### Model Designation

Model CH20S for example: C designates Command engine, H designates horizontal crankshaft, and 20 designates horsepower. Some model numbers (CH730) use a numerical designation rather than horsepower. A letter suffix designates a specific version as follows:

Suffix	Designates
S	Electric Start
ST	Electric Start/Retractable Start
QS	Quiet Model/Electric Start
EP	Electric Plant
CS	Clutch Model/Electric Start

### Operating Instructions

Also read the operating instructions of the equipment this engine powers.

### Pre-Start Checklist

- Check oil level. Add oil if low. Do not overfill.
- Check fuel level. Add fuel if low.
- Check cooling air intake areas and external surfaces of engine. Make sure they are clean and unobstructed.
- Check that the air cleaner components and all shrouds, equipment covers, and guards are in place and securely fastened.

- Check that any clutches or transmissions are disengaged or placed in neutral. This is especially important on equipment with hydrostatic drive. The shift lever must be exactly in neutral to prevent resistance which could keep the engine from starting.



**WARNING: Lethal Exhaust Gases!**

Engine exhaust gases contain poisonous carbon monoxide. Carbon monoxide is odorless, colorless, and can cause death if inhaled. Avoid inhaling exhaust fumes, and never run the engine in a closed building or confined area.

**Cold Weather Starting Hints**

1. Be sure to use the proper oil for the temperature expected. See Figure 3 on page 5.
2. Disengage all possible external loads.
3. Be sure the battery is in good condition. A warm battery has much more starting capacity than a cold battery.
4. Use fresh winter grade fuel. NOTE: Winter grade gasoline has higher volatility to improve starting. Do not use gasoline left over from summer.

**Starting**

1. Place the throttle control **midway** between the **slow** and **fast** positions. Place the choke control (non-EFI engines only) into the **on** position. See Figure 6.



**Figure 6. Optional Engine Mounted Throttle and Choke Controls (Carbureted Engines).**

2. Start the engine by activating the key switch. Release the switch as soon as the engine starts.

**EFI Engines Only – Initial Starting or After Running out of Fuel (Dry System)**

- a. Turn the key switch to the **on** position for one minute. Allow the fuel pump to cycle and prime the system. Turn the key switch **off**.
- b. Turn the key switch to the **start** position, crank and start engine.

- c. If the engine fails to start, repeat steps **a** and **b**. If the engine does not start after two priming intervals, contact your Kohler Engine Service Dealer for further assistance.

NOTE: Do not crank the engine continuously for more than 10 seconds at a time. If the engine does not start, allow a 60 second cool down period between starting attempts. Failure to follow these guidelines can burn out, or permanently damage, the starter motor.

NOTE: Upon start-up, a metallic ticking may occur. This is caused by hydraulic lifter leakdown during storage. Run the engine for 5 minutes. The noise will normally cease in the first minute. If noise continues, run the engine at mid-throttle for 20 minutes. If noise persists, take the engine to your local authorized Kohler Engine Service Dealer.

NOTE: If the engine develops sufficient speed to disengage the starter but does not keep running (a false start), engine rotation must be allowed to come to a complete stop before attempting to restart the engine. If the starter is engaged while the flywheel is rotating, the starter pinion and flywheel ring gear may clash resulting in damage to the starter.

If the starter does not turn the engine over, shut off starter immediately. Do not make further attempts to start the engine until the condition is corrected. Do not jump start using another battery (refer to **Battery** on page 8). See your Kohler Engine Service Dealer for service assistance.

**Carbureted Engines Only:**

3. **For a Cold Engine** – Gradually return the choke control to the **off** position after the engine starts and warms up.

The engine/equipment may be operated during the warm-up period, but it may be necessary to leave the choke partially on until the engine warms up.

4. **For a Warm Engine** – Return choke to **off** position as soon as engine starts.

---

## Stopping

1. Remove the load by disengaging all PTO driven attachments.
2. **For Carbureted Engines Without A Shutdown Solenoid:** Move the throttle to the **slow** or **low** idle position. Allow the engine to run at idle for 30-60 seconds; then stop the engine.

**For Carbureted Engines Equipped With A Shutdown Solenoid:** Position the throttle control somewhere between half and full throttle; then stop the engine.

**For EFI Engines:** Move the throttle to the **slow** or **idle** position; turn key **off** to stop engine.

## Battery

A 12 volt battery is normally used. Refer to the operating instructions of the equipment this engine powers for specific battery requirements.

If the battery charge is not sufficient to crank the engine, recharge the battery (see page 13).

## Operating

### Angle of Operation

This engine will operate continuously at angles up to 25°. Check oil level to assure crankcase oil level is at the "F" mark on the dipstick.

Refer to the operating instructions of the equipment this engine powers. Because of equipment design or application, there may be more stringent restrictions regarding the angle of operation.

**NOTE:** Do not operate this engine continuously at angles exceeding 25° in any direction. Engine damage could result from insufficient lubrication.

## Cooling

**NOTE:** If debris builds up on the grass screen or other cooling air intake areas, stop the engine immediately and clean. Operating the engine with blocked or dirty air intake and cooling areas can cause extensive damage due to overheating.



### **WARNING: Hot Parts!**

*Engine components can get extremely hot from operation. To prevent severe burns, do not touch these areas while the engine is running, or immediately after it is turned off. Never operate the engine with heat shields or guards removed.*

## Engine Speed

**NOTE:** Do not tamper with the governor setting to increase the maximum engine speed. Overspeed is hazardous and will void the engine warranty. The maximum allowable high idle speed for these engines is 3750 RPM, no load.

## Maintenance Instructions

**Maintenance, repair, or replacement of the emission control devices and systems, which are being done at the customers expense, may be performed by any non-road engine repair establishment or individual. Warranty repairs must be performed by an authorized Kohler service outlet.**



### **WARNING: Accidental Starts!**

*Disabling engine. Accidental starting can cause severe injury or death. Before working on the engine or equipment, disable the engine as follows: 1) Disconnect the spark plug lead(s). 2) Disconnect negative (-) battery cable from battery.*

## Maintenance Schedule

These required maintenance procedures should be performed at the frequency stated in the table. They should also be included as part of any seasonal tune-up.

Frequency	Maintenance Required
Daily or Before Starting Engine	<ul style="list-style-type: none"> <li>• Fill fuel tank.</li> <li>• Check oil level.</li> <li>• Check air cleaner for dirty<sup>1</sup>, loose, or damaged parts.</li> <li>• Check air intake and cooling areas, clean as necessary<sup>1</sup>.</li> </ul>
Every 25 Hours	<ul style="list-style-type: none"> <li>• Service precleaner element<sup>1</sup>.</li> </ul>
Every 100 Hours	<ul style="list-style-type: none"> <li>• Replace air cleaner element<sup>1</sup>.</li> <li>• Change oil. (More frequently under severe conditions.)</li> <li>• Remove cooling shrouds and clean cooling areas<sup>1,3</sup>.</li> <li>• Check oil cooler fins, clean as necessary (if equipped).</li> </ul>
Every 200 Hours	<ul style="list-style-type: none"> <li>• Check spark plug condition and gap.</li> <li>• Change oil filter.</li> <li>• Replace fuel filter (carbureted engines).</li> </ul>
Every 250 Hours	<ul style="list-style-type: none"> <li>• Replace heavy-duty air cleaner element and check inner element<sup>1</sup>.</li> </ul>
Annually or Every 500 Hours	<ul style="list-style-type: none"> <li>• Have bendix starter drive serviced<sup>2,4</sup>.</li> <li>• Have solenoid shift starter disassembled and cleaned<sup>2,4</sup>.</li> </ul>
Every 500 Hours	<ul style="list-style-type: none"> <li>• Have crankshaft spline lubricated<sup>2</sup>.</li> </ul>
Every 1500 Hours	<ul style="list-style-type: none"> <li>• Replace fuel filter<sup>1</sup> (EFI engines).</li> </ul>

<sup>1</sup>Perform these maintenance procedures more frequently under extremely dusty, dirty conditions.

<sup>2</sup>Have a Kohler Engine Service Dealer perform this service.

<sup>3</sup>Cleanout Kits 25 755 20-S (black) or 25 755 21-S (gold) allow cooling areas to be cleaned without removing shrouds.

<sup>4</sup>Only required for Denso starters. Not necessary on Delco starters.

### Check Oil Level

The importance of checking and maintaining the proper oil level in the crankcase cannot be overemphasized. Check oil **BEFORE EACH USE** as follows:

1. Make sure the engine is stopped, level, and is cool so the oil has had time to drain into the sump.
2. To keep dirt, debris, etc., out of the engine, clean the area around the dipstick before removing it.
3. Remove the dipstick; wipe oil off. Reinsert the dipstick into the tube and press all the way down.
4. Remove the dipstick and check the oil level. The oil level should be up to, but not over, the "F" mark on the dipstick. See Figure 7.

5. If the level is low, add oil of the proper type, up to the "F" mark on the dipstick. (Refer to Oil Type on page 5.) Always check the level with the dipstick before adding more oil.

**NOTE:** To prevent extensive engine wear or damage, always maintain the proper oil level in the crankcase. Never operate the engine with the oil level below the "L" mark or over the "F" mark on the dipstick.

### Oil Sentry™

Some engines are equipped with an optional Oil Sentry™ oil pressure switch. If the oil pressure decreases below an acceptable level, the Oil Sentry™ will either shut off the engine or activate a warning signal, depending on the application.

**NOTE:** Make sure the oil level is checked **BEFORE EACH USE** and is maintained up to the "F" mark on the dipstick. This includes engines equipped with Oil Sentry™.

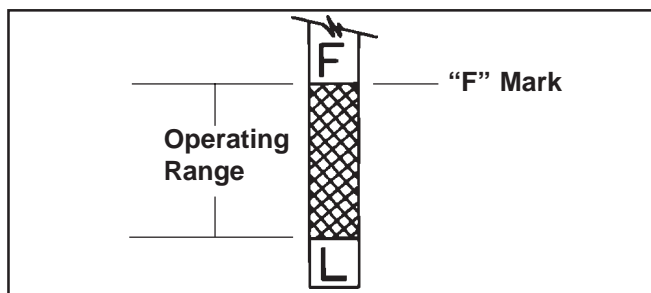

Figure 7. Oil Level Dipstick.



## Change Oil and Filter, Service Oil Cooler

### Change Oil

Change oil after every **100 hours** of operation (more frequently under severe conditions). Refill with service class SG, SH, SJ or higher oil as specified in the Viscosity Grades table (Figure 3) on page 5.

Change the oil while the engine is still warm. The oil will flow more freely and carry away more impurities. Make sure the engine is level when filling, checking, and changing the oil.

Change the oil as follows (see Figures 8 and 9):

1. To keep dirt, debris, etc., out of the engine, clean the area around the oil fill cap/dipstick before removing it.
2. Remove one of the oil drain plugs, oil fill cap, and dipstick. Be sure to allow ample time for complete drainage.
3. Reinstall the drain plug. Make sure it is tightened to **13.6 N·m (10 ft. lb.)** torque.
4. Fill the crankcase, with new oil of the proper type, to the "F" mark on the dipstick. Refer to Oil Type on page 5. Always check the level with the dipstick before adding more oil.
5. Reinstall the oil fill cap and tighten securely. Reinstall dipstick.

**NOTE:** To prevent extensive engine wear or damage, always maintain the proper oil level in the crankcase. Never operate the engine with the oil level below the "L" mark or over the "F" mark on the dipstick.

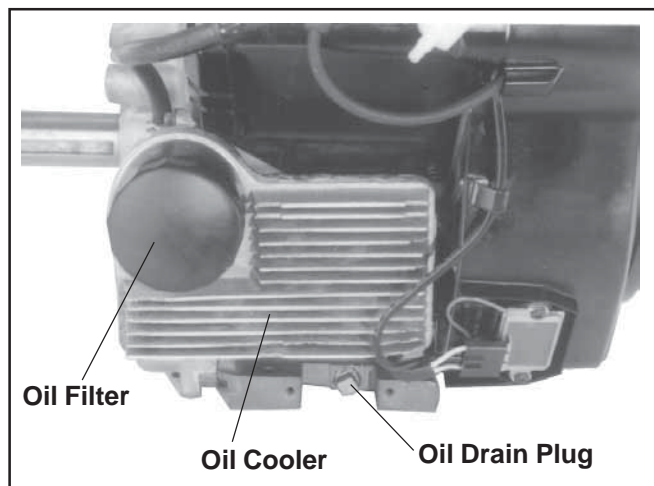

**Figure 8. Oil Drain Plugs, Oil Filter, and Oil Cooler (Crankcase Mounted).**

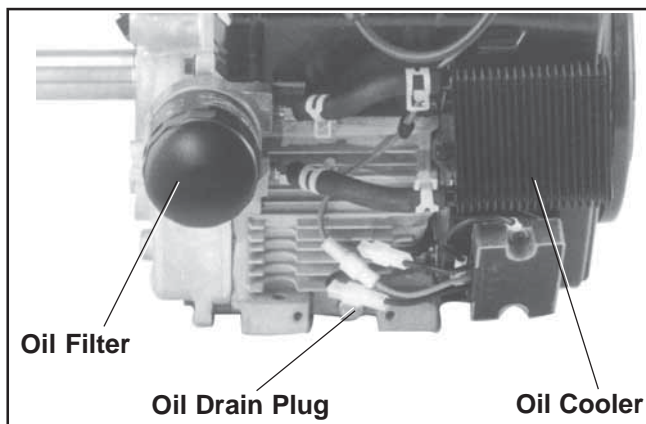

**Figure 9. Oil Drain Plugs, Oil Filter, and Oil Cooler (Blower Housing Mounted).**

### Change Oil Filter

Replace the oil filter **at least every other oil change (every 200 hours of operation)**. Always use a genuine Kohler oil filter. Use chart below to determine part number to order.

Oil Filter Part No.	Length
12 050 01-S	2-1/2"
52 050 02-S	3-3/8"

Replace the oil filter as follows:

1. Drain the oil from the engine crankcase.
2. Allow the oil filter to drain.
3. Before removing the oil filter, clean the area around the oil filter to keep dirt and debris out of the engine. Remove the old filter. Wipe off the surface where the oil filter mounts.
4. Place a new replacement filter in a shallow pan with the open end up. Pour new oil, of the proper type, in through the threaded center hole. Stop pouring when the oil reaches the bottom of the threads. Allow a minute or two for the oil to be absorbed by the filter material.
5. Apply a thin film of clean oil to the rubber gasket on the new filter.
6. Install the replacement oil filter to the filter adapter or oil cooler. Turn the oil filter clockwise until the rubber gasket contacts the filter adapter or oil cooler, then tighten the filter an additional **3/4 to 1 turn**.
7. Reinstall the drain plug. Make sure it is tightened to **13.6 N·m (10 ft. lb.)** torque.
8. Fill the crankcase with new oil of the proper type to the "F" mark on the dipstick.

- Start the engine and check for oil leaks. Correct any leaks before placing the engine into service. Check oil level to be sure it is up to but not over the "F" mark.

### Service Oil Cooler

Some engines are equipped with an oil cooler. One style of oil cooler mounts on the engine crankcase and has the oil filter on it (See Figure 8). The other style of oil cooler is mounted on the blower housing (see Figure 9), separate from the oil filter.

Inspect and clean the oil cooler **every 100 hours of operation** (more frequently under severe conditions). Oil cooler must be kept free of debris.

To service the crankcase mounted oil cooler clean off the outside fins with a brush or with compressed air.

To service the blower housing mounted oil cooler, clean the outside of fins with a brush. Remove the two screws holding the cooler unit to the blower housing. Tilt the cooler downward as shown in Figure 10. Clean the inside of cooler with a brush as shown in Figure 10 or with compressed air. After cleaning, reinstall oil cooler to blower housing with two mounting screws.



**Figure 10. Cleaning Oil Cooler.**

### Service Precleaner and Air Cleaner Element

This engine is equipped with a replaceable, high density paper air cleaner element. Most engines are also equipped with an oiled, foam precleaner which surrounds the paper element. See Figure 11. Some engines use the heavy-duty air cleaner system. See Figure 13.

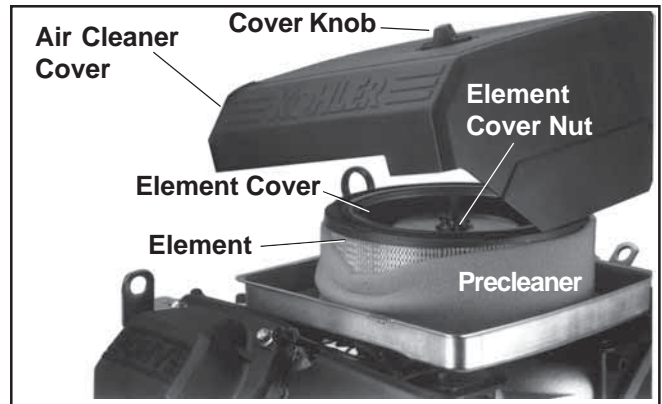

**Figure 11. Air Cleaner System Components.**

Check the air cleaner **daily or before starting the engine**. Check for a buildup of dirt and debris around the air cleaner system. Keep this area clean. Also check for loose or damaged components. Replace all bent or damaged air cleaner components.

**NOTE:** Operating the engine with loose or damaged air cleaner components could allow unfiltered air into the engine causing premature wear and failure.

### Service Precleaner

If so equipped, wash and reoil the precleaner every **25 hours** of operation (more often under extremely dusty or dirty conditions).

- Loosen the cover retaining knob and remove the cover.
- Remove the precleaner from the paper element.
- Wash the precleaner in warm water with detergent. Rinse the precleaner thoroughly until all traces of detergent are eliminated. Squeeze out excess water (do not wring). Allow the precleaner to air dry.
- Saturate the precleaner with new engine oil. Squeeze out all excess oil.
- Reinstall the precleaner over the paper element.
- Reinstall the air cleaner cover. Secure cover with the cover retaining knob.
- When precleaner replacement is necessary, order genuine Kohler parts.

24 083 02-S	61 mm (2.40 in.) high x 173 mm (6.81 in.) O.D.
24 083 05-S	71 mm (2.79 in.) high x 173 mm (6.81 in.) O.D.



## Service Paper Element

Every **100 hours** of operation (more often under extremely dusty or dirty conditions) replace the paper element.

1. Loosen the cover retaining knob and remove the cover.
2. Remove the element cover nut, element cover, and paper element with precleaner.
3. Remove the precleaner (if so equipped) from the paper element. Service the precleaner as described above.
4. **Do not wash the paper element or use pressurized air**, as this will damage the element. Replace a dirty, bent, or damaged element with a genuine Kohler element. Handle new elements carefully; do not use if the sealing surfaces are bent or damaged.
5. When servicing the air cleaner, check the air cleaner base. Make sure it is secured and not bent or damaged. Also, check the element cover for damage or improper fit. Replace all damaged air cleaner components.

**NOTE:** If any loose dirt or debris fell on the air cleaner base when the element was removed, carefully remove it and wipe the base clean. Be careful that none of it drops into the intake throat. Check the condition of the rubber seal on the air cleaner stud. If the condition is questionable in any way, replace it with the new seal packaged with the replacement element.

6. Reinstall the paper element, precleaner, element cover, element cover nut, and air cleaner cover. Secure cover with the cover retaining knob.
7. When element replacement is necessary, order genuine Kohler parts.

47 083 03-S	65 mm (2.55 in.) high x 178 mm (7.00 in.) O.D.
24 083 03-S	74 mm (2.91 in.) high x 178 mm (7.00 in.) O.D.

## Heavy-Duty Air Cleaner

### To Service

Every **250 hours** of operation (more often under extremely dusty or dirty conditions), replace the paper element and check inner element. Follow these steps.

1. Unhook the two retaining clips and remove the end cap from the air cleaner housing.

2. Pull the air cleaner element out of the housing. See Figure 12.

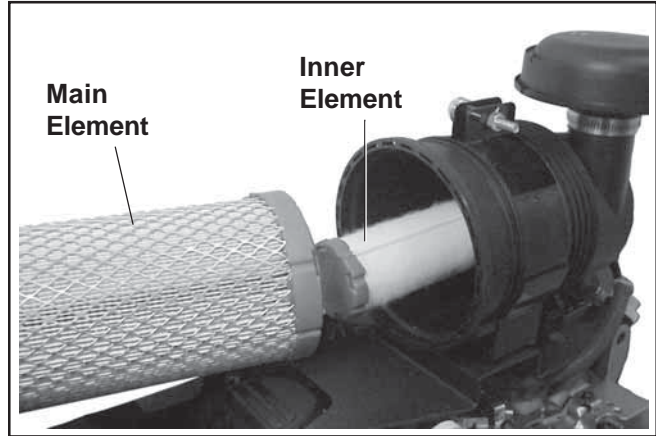

**Figure 12. Removing Elements.**

3. After the main element is removed, check the condition of the inner element. It should be replaced whenever it appears dirty, typically every other time the main element is replaced. Clean the area around the base of the inner element before removing it, so dirt does not get into the engine.
4. **Do not** wash the paper element and inner element or use pressurized air, this will damage the elements. Replace dirty, bent or damaged elements with new genuine Kohler elements as required. Handle new elements carefully; do not use if the sealing surfaces are bent or damaged.
5. Check all parts for wear, cracks, or damage. Replace any damaged components.
6. Install the new inner element, Kohler Part No. **25 083 04-S** followed by the outer element, Kohler Part No. **25 083 01-S**. Slide each fully into place in the air cleaner housing.
7. Reinstall the end cap so the dust ejector valve is down and secure with the two retaining clips. See Figure 13.

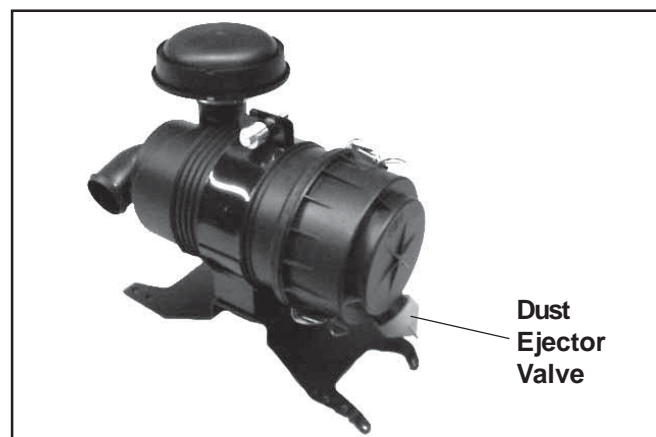

**Figure 13. Heavy-Duty Air Cleaner Assembly.**

### Clean Air Intake/Cooling Areas

To ensure proper cooling, make sure the grass screen, cooling fins, and other external surfaces of the engine are kept clean **at all times**.

Every **100 hours** of operation (more often under extremely dusty, dirty conditions), remove the blower housing\* and other cooling shrouds. Clean the cooling fins and external surfaces as necessary. Make sure the cooling shrouds are reinstalled.

NOTE: Operating the engine with a blocked grass screen, dirty or plugged cooling fins, and/or cooling shrouds removed, will cause engine damage due to overheating.

\*Cleanout kits 25 755 20-S (black) or 25 755 21-S (gold) allow inspection and cleanout of the cooling fins, without removing the blower housing.

### Ignition System

**Carbureted Engines** - Use an electronic Capacitive Discharge (CD) ignition system. Other than periodically checking/replacing the spark plugs, no maintenance, timing, or adjustments are necessary or possible with this system.

**EFI Engines** - Incorporate a computer-controlled battery ignition system with individual coils. Other than periodically checking/replacing the spark plugs, no maintenance, timing, or adjustments are necessary or possible with this system.

### Check Spark Plugs

Every **200 hours** of operation, remove the spark plugs, check condition, and reset the gap or replace with new plugs as necessary. The standard spark plug is a Champion® RC12YC (Kohler Part No. 12 132 02-S). RFI complaint engines use a Champion® XC12YC (Kohler Part No. 25 132 14-S) spark plug. A high-performance spark plug, Champion® Platinum 3071 (used on Pro Series engines, Kohler Part No. 25 132 12-S) is also available. Equivalent alternate brand plugs can also be used.

1. Before removing the spark plug, clean the area around the base of the plug to keep dirt and debris out of the engine.
2. Remove the plug and check its condition. Replace the plug if worn or reuse is questionable.

NOTE: Do not clean the spark plug in a machine using abrasive grit. Some grit could remain in the spark plug and enter the engine causing extensive wear and damage.

3. Check the gap using a wire feeler gauge. Adjust the gap to **0.76 mm (0.030 in.)** by carefully bending the ground electrode. See Figure 14.

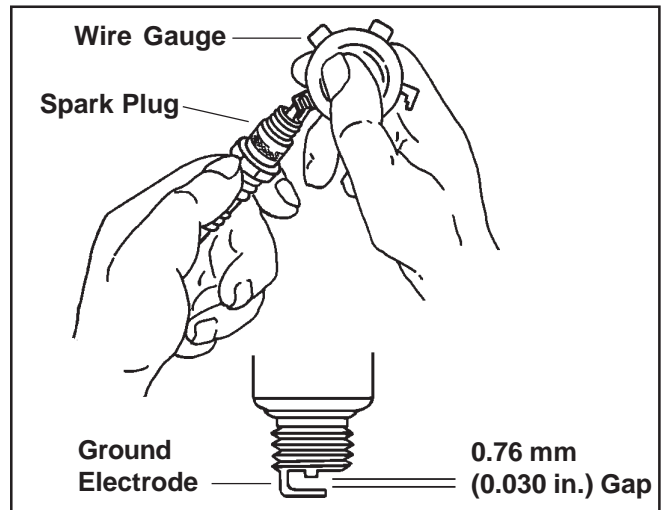

Figure 14. Servicing Spark Plug.

4. Reinstall the spark plug into the cylinder head. Torque the spark plug to **24.4-29.8 N·m (18-22 ft. lb.)**.

### Battery Charging



#### WARNING: Explosive Gas!

*Batteries produce explosive hydrogen gas while being charged. To prevent a fire or explosion, charge batteries only in well ventilated areas. Keep sparks, open flames, and other sources of ignition away from the battery at all times. Keep batteries out of the reach of children. Remove all jewelry when servicing batteries.*

*Before disconnecting the negative (-) ground cable, make sure all switches are OFF. If ON, a spark will occur at the ground cable terminal which could cause an explosion if hydrogen gas or gasoline vapors are present.*

NOTE: Do not apply 12 volt DC to kill terminal of ignition module.

### Fuel System



#### WARNING: Fuel System Under Pressure!

*The EFI fuel system operates under high pressure, and the fuel filter and fuel line used must be approved system components only. Use of substitute parts can result in system failure, gasoline leakage and possible explosion.*

### Fuel Filter

**Carbureted Engines:** Most engines are equipped with an in-line fuel filter. Periodically inspect the filter and replace with a genuine Kohler filter every **200 operating hours**.

**EFI Engines:** A special, high volume, high pressure filter with greater filtration capabilities and internal surface area is used. See Figure 15.

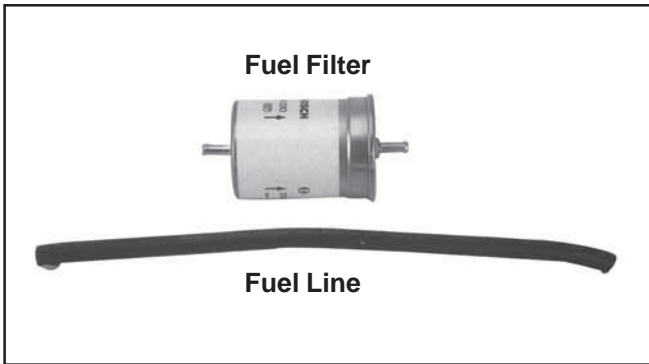

**Figure 15. EFI Fuel Filter and Line.**

Replacement is recommended every **1500 hours**, or more frequently under extremely dusty or dirty conditions. When replacement is necessary, always use genuine Kohler parts.

### Fuel Line

**Carbureted Engines:** In compliance with CARB Tier III Emission Regulations, carbureted engines with a **Family** identification number beginning with "6" or greater (see Figure 16), must use Low Permeation SAE 30 R7 rated fuel line; certified to meet CARB requirements. Standard fuel line may not be used. Order replacement hose by part number through a Kohler Engine Service Dealer.

**KOHLER**

IMPORTANT ENGINE INFORMATION  
THIS ENGINE MEETS U.S. EPA AND CA 2005 AND LATER AND EC STAGE II (SN:4) EMISSION REGS FOR SI SMALL OFF-ROAD ENGINES

**FAMILY**      ↗ 6 KHXS.7252 PH

**TYPE APP**

**DISPL. (CC)**

**MODEL NO.**      ✓ N11236

**SPEC. NO.**

**SERIAL NO.**

**BUILD DATE**

**OEM PROD. NO.**

EMISSION COMPLIANCE PERIOD:  
EPA:                      CARB:

CERTIFIED ON:  
REFER TO OWNER'S MANUAL FOR HP RATING, SAFETY, MAINTENANCE AND ADJUSTMENTS  
1-800-544-2444 www.kohlerengines.com

KOHLER CO. KOHLER, WISCONSIN USA

**Figure 16. Family Number Location.**

**EFI Engines:** A special fuel line, capable of withstanding the high pressure of the EFI fuel system, is used (must meet SAE R9 specifications). See Figure 15. If fuel line must be replaced, see your Kohler Engine Service Dealer.

## Carburetor Troubleshooting and Adjustments

Engines in this series use either a one- or two-barrel carburetor depending on model, and may also be equipped with a Governed Idle System. Specific adjustment procedures are provided based on the model and carburetor involved. If the engine is equipped with a Governed Idle System, refer to **Models with Governed Idle System** on page 15 when performing any carburetor adjustment, as an additional step to the listed adjustment procedure(s) is required.

**NOTE:** Carburetor adjustments should be made only after the engine has warmed up.

The carburetor is designed to deliver the correct fuel-to-air mixture to the engine under all operating conditions. To comply with current emission regulations, the fuel mixture settings are made at the factory and cannot be adjusted.

**NOTE:** To ensure correct engine operation at altitudes above 1525 meters (5000 ft.), it may be necessary to have an authorized Kohler dealer install a special high-altitude jet kit in the carburetor. If a high-altitude kit has been installed, the engine must be reconverted to the original jet size, before it is operated at lower altitudes, or overheating and engine damage can result.

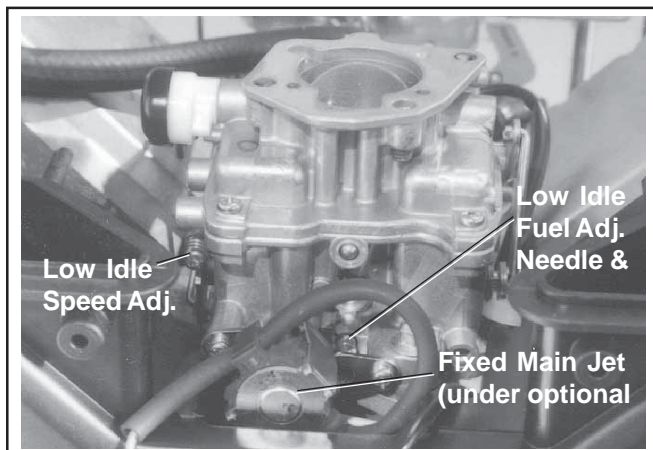

**Figure 17. Carburetor (CH18-25, CH730, 740).**

### Troubleshooting

If engine troubles are experienced that appear to be fuel system related, check the following areas before adjusting the carburetor.

- Make sure the fuel tank is filled with clean, fresh gasoline.
- Make sure the fuel tank cap vent is not blocked and that it is operating properly.



- If the fuel tank is equipped with a shut-off valve, make sure it is open.
- If the engine is equipped with an in-line fuel filter, make sure it is clean and unobstructed. Replace the filter if necessary.
- Make sure fuel is reaching the carburetor. This includes checking the fuel lines and fuel pump for restrictions or faulty components, replace as necessary.
- Make sure the air cleaner element is clean and all air cleaner element components are fastened securely.

If, after checking the items listed above, the engine is hard to start, runs roughly, or stalls at low idle speed, it may be necessary to adjust or service the carburetor.

## Adjust Carburetor

### Models CH18-740

There are no accessible mixture adjustment screws on the carburetor. The only setting which can be changed is the low idle speed.

1. Start the engine and run at half throttle for 5 to 10 minutes to warm up. The engine must be warm before making final settings (steps 2 and 3).
2. **Low Idle Speed Setting:** Place the throttle control into the **idle** or **slow** position. Set the low idle speed to **1200 RPM\*** ( $\pm 75$  RPM) by turning the low idle speed adjusting screw **in** or **out**. Check the speed using a tachometer.

\*NOTE: The actual low idle speed depends on the application – refer to equipment manufacturers recommendations. The standard low idle speed is 1200 RPM.

3. If proper operation is not restored after adjusting the low idle speed, carburetor servicing by an authorized Kohler Engine Service Dealer may be required.

### Models with Governed Idle System

An optional governed idle control system is supplied on some CH18-740 engines. The purpose of this system is to maintain a desired idle speed regardless of ambient conditions (temperature, parasitic load, etc.) that may change. Engines with this feature contain a small secondary spring connected between the governor lever and the lower adjustment tab of the main bracket. See Figure 18.

The system requires an additional procedure for setting the idle speed. If speed adjustments are required proceed as follows.

1. Make any necessary speed or control adjustments following the appropriate instructions covered in this section.
2. Move the throttle control to the idle position. Hold the governor lever away from the carburetor, or hold the throttle lever so it is tight against the idle speed adjusting screw, to negate the governor activation. See Figure 19. Check the speed with a tachometer and adjust it to 1500 RPM.
3. Release the governor lever and allow the engine to return to the governed idle speed. Check it with a tachometer against the equipment manufacturers recommended idle speed. Governed Idle Speed (RPM) is typically 300 RPM (approximate) higher than the low idle speed. If adjustment is necessary, bend the adjusting tab on the speed control assembly to set. See Figure 18.

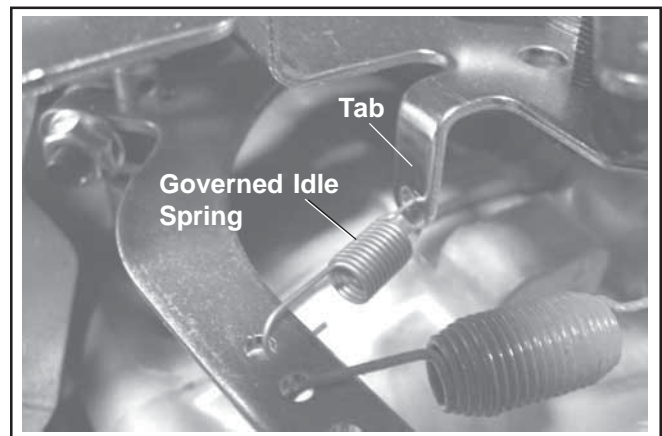

Figure 18. Governed Idle Spring Location.

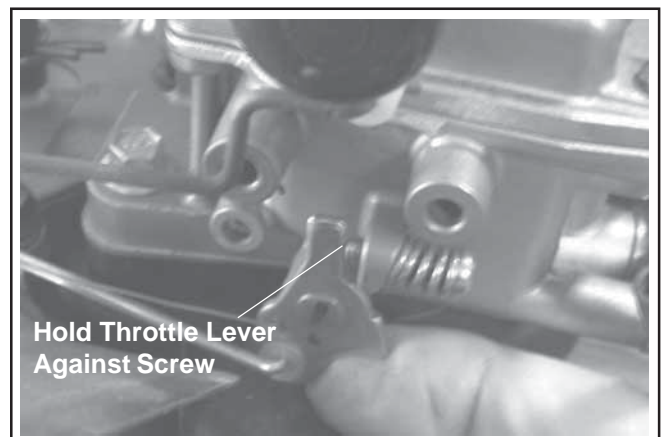

Figure 19. Holding Throttle Lever Against Idle Stop Screw.

## Model CH750

CH750 engines use a Keihin BK two-barrel carburetor with fixed main jets and fixed or limiter-equipped low idle fuel adjusting needles. See Figure 20. Adjustments are made as follows.

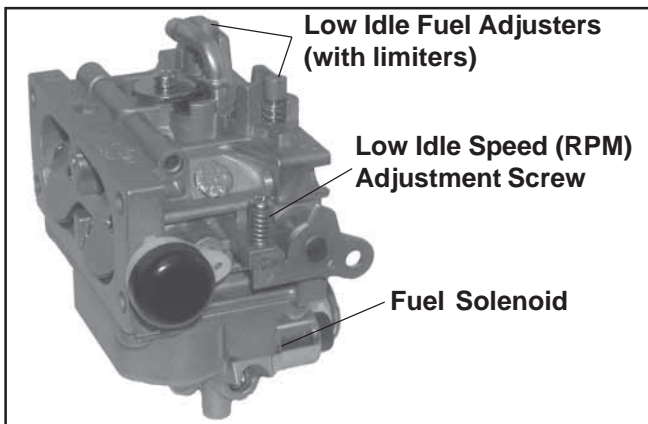

Figure 20. Keihin Two-Barrel Carburetor.

### Low Idle Speed (RPM) Adjustment

1. **Low Idle Speed (RPM) Setting:** Place the throttle control into the **idle** or **slow** position. Set the low idle speed to **1200 RPM\*** ( $\pm 75$  RPM) by turning the low idle speed adjusting screw **in or out**. Check the speed using a tachometer.

\*NOTE: The actual low idle speed depends on the application. Refer to the equipment manufacturer's recommendations. The low idle speed for basic engines is 1200 RPM. To ensure best results when setting the low idle fuel needle, the low idle speed should be 1200 RPM ( $\pm 75$  RPM).

### Low Idle Fuel Adjustment

NOTE: Engines will have fixed low idle or limiter caps on the two idle fuel adjusting needles. Step 3 can only be performed within the limits allowed by the cap. Do not attempt to remove the limiter caps.

1. Start the engine and run at half throttle for 5 to 10 minutes to warm up. The engine must be warm before doing steps 2, 3, and 4.
2. Place the throttle control into the **idle** or **slow** position. Adjust the low idle speed to **1200 RPM\***. Follow the **Adjusting the Low Idle Speed (RPM)** procedure.
3. **Low Idle Fuel Needle(s) Setting:** Place the throttle into the **idle** or **slow** position.
  - a. Turn one of the low idle fuel adjusting needles out (counterclockwise) from the preliminary setting until the engine speed decreases (rich). Note the position of the needle. Now turn the

adjusting needle in (clockwise). The engine speed may increase, then it will decrease as the needle is turned **in** (lean). Note the position of the needle. Set the adjusting needle midway between the rich and lean settings. See Figure 21.

- b. Repeat the procedure on the other low idle adjustment needle.
4. Recheck/adjust the **Low Idle Speed (RPM)**, to the specified setting.

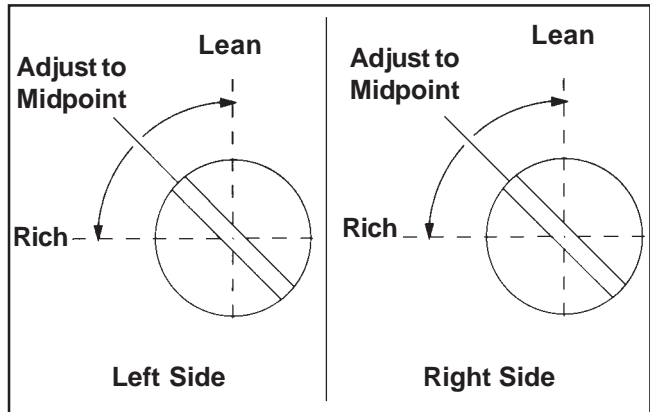

Figure 21. Optimum Low Idle Fuel Settings.

### Models with Governed Idle System

An optional governed idle control system is supplied on some CH750 engines. The purpose of this system is to maintain a desired idle speed regardless of ambient conditions (temperature, parasitic load, etc.) that may change. Engines with this feature contain a small secondary spring connected between the governor lever and the lower adjustment tab of the main bracket. See Figure 18. Refer to the same adjustment procedure covered in **Models with Governed Idle System** for the CH18-740 models on page 15, when adjustments are required.

### Electronic Fuel Injection (EFI) System

The EFI system is a complete, electronically-controlled fuel management system, designed to deliver a precisely controlled fuel flow under all operating conditions. The electronic control unit (ECU), the **brain** of the system, automatically adjusts fuel delivery and ignition timing based upon load, speed, operating temperature, and exhaust emission levels. The low idle speed is the only manual adjustment possible.

The ECU continuously monitors operation of the EFI system. If it detects a problem or fault within the system, it will illuminate the malfunction indicator light (MIL), which is mounted in view of the operator. This is a signal that normal, programmed operation has been affected, and service by an authorized Kohler Engine Dealer is required.

NOTE: The EFI system requires a rather complex wiring harness to carry the electrical signals between the sensors and the ECU. **Do not** spray water at the wiring harness or any of the electrical components, especially the ECU, as it could cause malfunction, damage, or failure.

### Troubleshooting

If the MIL comes on, or the engine becomes hard to start, runs roughly, or stalls at low idle speed, initial checks should be made in the following areas:

- Make sure the fuel tank is filled with clean, fresh gasoline, and shut-off valve (if so equipped) is opened completely.
- Make sure fuel tank vent cap is not blocked and it is operating properly.
- Make sure the air cleaner element and precleaner are clean and all components are properly secured. Clean or replace as necessary.
- Make sure the proper fuel filter is being used, and it is clean and unobstructed. Replace filter **only** with genuine Kohler parts.
- Make sure all connections to sensors, ECU, and fuel injectors are properly secured.
- Make sure a good 12 volt battery is being used and is fully charged.

If these checks do not correct the problem, or the MIL remains on, further diagnosis and servicing by an authorized Kohler Engine Dealer is necessary.

### Adjustment – EFI Throttle Body

**Low Idle Speed (RPM)** is the only adjustment that can be made. All other fuel calibrations are permanently preset and controlled by the ECU. The standard low idle speed is **1500 RPM\*** (+ 75 RPM).

\*NOTE: The actual low idle speed depends on the application -- refer to equipment manufacturer's recommendations.

When an EFI engine is started cold, the ECU will be using internal programming for cold running, and the idle speed may vary from the manual setting. Do not attempt to perform any readjustment during this warm-up period.

If adjustment is to be made, the engine must be at operating temperature, air cleaner in place, and check engine light must be off (no fault codes present).

1. Start the engine and run at half throttle for 5 to 10 minutes to warm up.
2. Place the throttle control into the **idle** or **slow** position.
3. Turn the low idle speed adjusting screw in or out and check RPM with a tachometer. See Figure 22.

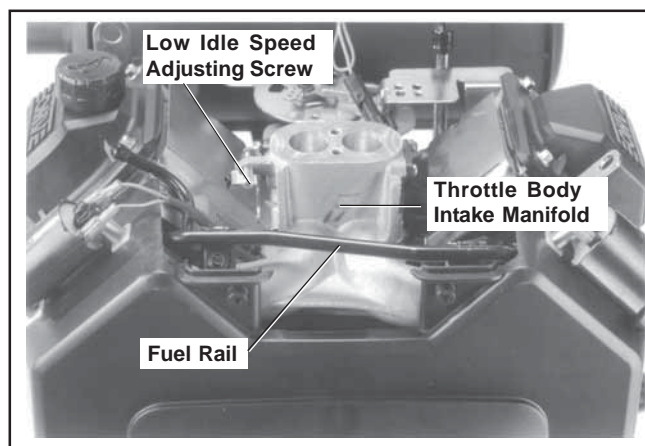

Figure 22. EFI Throttle Body Manifold.

### Troubleshooting

When troubles occur, be sure to check the simple causes which, at first, may seem too obvious to be considered. For example, a starting problem could be caused by an empty fuel tank. Some common causes of engine troubles are listed in the following table.

Do not attempt to service or replace major engine components, or any items that require special timing or adjustment procedures. Have your Kohler Engine Service Dealer do this work.

Possible Cause Problem	No Fuel	Improper Fuel	Dirt In Fuel Line/System	Dirty Grass Screen	Incorrect Oil Level	Engine Overloaded	Dirty Air Cleaner	Faulty Spark Plug
Will Not Start	•	•	•		•	•	•	•
Hard Starting		•	•		•	•	•	•
Stops Suddenly	•		•	•	•	•	•	
Lacks Power		•	•	•	•	•	•	•
Operates Erratically		•	•	•		•	•	•
Knocks or Pings		•		•		•		•
Skips or Misfires		•	•	•			•	•
Backfires			•			•	•	•
Overheats			•	•	•	•	•	
High Fuel Consumption						•	•	•



## Storage

If the engine will be out of service for two months or more, use the following storage procedure:

1. Clean the exterior surfaces of the engine. On EFI engines, avoid spraying water at the wiring harness or any of the electrical components.
2. Change the oil and filter while the engine is still warm from operation. See Change Oil and Filter on page 9.
3. The fuel system must be completely emptied, or the gasoline must be treated with a stabilizer to prevent deterioration. If you choose to use a stabilizer, follow the manufacturers recommendations, and add the correct amount for the capacity of the fuel system. Fill the fuel tank with clean, fresh gasoline. Run the engine for 2-3 minutes to get stabilized fuel into the rest of the system. Close fuel shut-off valve when unit is being stored or transported.

To empty the system, run the engine until the tank and fuel system are empty.

4. Remove the spark plugs. Add one tablespoon of engine oil into each spark plug hole. Install the plugs, but do not connect the plug leads. Crank the engine two or three revolutions.

5. On units with EFI engines, disconnect the negative (-) battery cable or use a battery minder trickle charger while the unit is in storage.
6. Store the engine in a clean, dry place.

## Parts Ordering

The engine Specification, Model, and Serial Numbers are required when ordering replacement parts from your Kohler Engine Service Dealer. These numbers are found on the identification plate which is affixed to the engine shrouding. Include letter suffixes if there are any. See Engine Identification Numbers on page 6.

*Always insist on genuine Kohler parts.* All genuine Kohler parts meet strict standards for fit, reliability, and performance.

## Major Repair

Major repair information is available in Kohler Engine Service Manuals. This type of repair generally requires the services of a trained mechanic and the use of special tools and equipment. Kohler Engine Service Dealers have the facilities, training, and genuine Kohler replacement parts necessary to perform this service.

For the nearest Sales & Service location:

- visit our website [www.kohlerengines.com](http://www.kohlerengines.com)
- call 1-800-544-2444 (U.S. & Canada)
- look in the yellow pages under Engines-Gasoline

## Specifications

Model:	..... CH18,20 .....	CH22,23 .....	CH730,26,740,745 .....	CH750
Bore:	..... mm (in.) ... 77 (3.03) .....	80 (3.2) .....	83 (3.27) .....	83 (3.27)
Stroke:	..... mm (in.) ... 67 (2.64) .....	67 (2.64) .....	67 (2.64) .....	69 (2.72)
Displacement:	..... cm <sup>3</sup> (in <sup>3</sup> ) ... 624 (38.1) .....	674 (41) .....	725 (44.0) .....	747 (45.6)
Power (@ 3600 RPM):	..... kW (HP) ... 13.4 (18*)/14.9 (20*) ...	16.4 (22*)/17.2 (23*) ...	18.6 (25*)/19.4 (26*) .....	22.4 (30*)
			20.1 (27*)/20.9(28*)	
Max. Peak Torque (@ RPM):	.. N·m (ft. lb.) ... 43.6 (32.2) @ 2200 .....	49.1 (36.2) @ 2400 .....	55.4 (40.9) @ 2400 .....	64.4 (47.5) @ 2400
	44.3 (32.7) @ 2400 .....	51.4 (37.9) @ 2400 .....	54.2 (40.0) @ 2800	
			57.3 (42.3) @ 2400	
			57.9 (42.7) @ 2600	
Compression Ratio:	..... 8.5:1 .....	8.5:1 .....	9.0:1 .....	9.4:1
Weight:	..... kg (lb.) ... 41 (90) .....	41 (90) .....	43 (94) .....	47 (105)
Oil Capacity (w/filter) - approximate, determined by oil filter and oil cooler used:	----- 1.6-1.8 L (1.7-1.9 U.S. qt.) -----			
Lubrication:	----- Full Pressure w/full Flow Filter -----			

Exhaust Emission Control System for models CH18,20,22,23,730,740,750 is EM.

Exhaust Emission Control System for models CH26 and CH745 are EM, O2S, ECM, MFI.

\*Horsepower ratings exceed Society of Automotive Engineers Small Engine Test Code J1940. Actual engine horsepower is lower and affected by, but not limited to, accessories (air cleaner, exhaust, charging, cooling, fuel pump, etc.), application, engine speed and ambient operating conditions (temperature, humidity, and altitude). Kohler reserves the right to change product specifications, designs and equipment without notice and without incurring obligation.

## LIMITED 2 YEAR COMMAND ENGINE WARRANTY

Kohler Co. warrants to the original consumer that each new COMMAND engine sold by Kohler Co. will be free from manufacturing defects in materials or workmanship in normal service for a period of two (2) years from date of purchase, provided it is operated and maintained in accordance with Kohler Co.'s instructions and manuals.

Our obligation under this warranty is expressly limited, at our option, to the replacement or repair at Kohler Co., Kohler, Wisconsin 53044, or at a service facility designated by us of such parts as inspection shall disclose to have been defective.

### EXCLUSIONS:

Mufflers on engines used commercially (non-residential) are warranted for one (1) year from date of purchase, except catalytic mufflers, which are warranted for two (2) years.

This warranty does not apply to defects caused by casualty or unreasonable use, including faulty repairs by others and failure to provide reasonable and necessary maintenance.

The following items are not covered by this warranty:

Engine accessories such as fuel tanks, clutches, transmissions, power-drive assemblies, and batteries, unless supplied or installed by Kohler Co. These are subject to the warranties, if any, of their manufacturers.

KOHLER CO. AND/OR THE SELLER SHALL NOT BE LIABLE FOR SPECIAL, INDIRECT, INCIDENTAL, OR CONSEQUENTIAL DAMAGES OF ANY KIND, including but not limited to labor costs or transportation charges in connection with the repair or replacement of defective parts.

IMPLIED OR STATUTORY WARRANTIES, INCLUDING WARRANTIES OF MERCHANTABILITY OR FITNESS FOR A PARTICULAR PURPOSE, ARE EXPRESSLY LIMITED TO THE DURATION OF THIS WRITTEN WARRANTY. We make no other express warranty, nor is any one authorized to make any on our behalf.

Some states do not allow limitations on how long an implied warranty lasts, or the exclusion or limitation of incidental or consequential damages, so the above limitation or exclusion may not apply to you.

This warranty gives you specific legal rights, and you may also have other rights which vary from state to state.

### TO OBTAIN WARRANTY SERVICE:

Purchaser must bring the engine to an authorized Kohler service facility. To locate the nearest facility, visit our website, [www.kohlerengines.com](http://www.kohlerengines.com), and click on SALES AND SERVICES to use the locator function, consult your Yellow Pages or telephone 1-800-544-2444.

ENGINE DIVISION, KOHLER CO., KOHLER, WISCONSIN 53044

## KOHLER CO. FEDERAL AND CALIFORNIA EMISSION CONTROL SYSTEMS LIMITED WARRANTY SMALL OFF-ROAD AND CLASS 1 LSI ENGINES

The U.S. Environmental Protection Agency (EPA), the California Air Resources Board (CARB), and Kohler Co. are pleased to explain the Federal and California Emission Control Systems Warranty on your off-road equipment engine. For California, small off-road engines produced in 1995 and later, and Class 1 LSI (Large Spark Ignited engines at or below 1.0 liter) produced in 2005 and later, must be designed, built and equipped to meet the state's stringent anti-smog standards. In other states, 1997 and later model year engines must be designed, built and equipped, to meet the U.S. EPA regulations for small non-road engines. The engine must be free from defects in materials and workmanship, which cause it to fail to conform with U.S. EPA standards for the first two years of engine use from the date of sale to the ultimate purchaser. Kohler Co. must warrant the emission control system on the engine for the period of time listed above, provided there has been no abuse, neglect or improper maintenance.

The emission control system may include parts such as the carburetor or fuel injection system, the ignition system, and catalytic converter. Also included are the hoses, belts and connectors and other emission-related assemblies.

Where a warrantable condition exists, Kohler Co. will repair the engine at no cost, including diagnosis (if the diagnostic work is performed at an authorized dealer), parts and labor.

### MANUFACTURER'S WARRANTY COVERAGE

Small off-road engines produced in 1995 or later, and Class 1 LSI engines produced in 2005 and later, are warranted for two years in California. In other states, 1997 and later model year engines are warranted for two years. If any emission related part on the engine is defective, the part will be repaired or replaced by Kohler Co. free of charge.

### OWNER'S WARRANTY RESPONSIBILITIES

(a) The engine owner is responsible for the performance of the required maintenance listed in the owner's manual. Kohler Co. recommends that you retain all receipts covering maintenance on the engine, but Kohler Co. cannot deny warranty solely for the lack of receipts or for your failure to assure that all scheduled maintenance was performed.

(b) Be aware, however, that Kohler Co. may deny warranty coverage if the engine or a part has failed due to abuse, neglect, improper maintenance or unapproved modifications.

Continued on next page.

- (c) For warranty repairs, the engine must be presented to a Kohler Co. service center as soon as a problem exists. Call 1-800-544-2444 or access our website at: www.kohlerengines.com, for the names of the nearest service centers. The warranty repairs should be completed in a reasonable amount of time, not to exceed 30 days.

If you have any questions regarding warranty rights and responsibilities, you should contact Kohler Co. at 1-920-457-4441 and ask for an Engine Service representative.

#### COVERAGE

Kohler Co. warrants to the ultimate purchaser and each subsequent purchaser that the engine will be designed, built and equipped, at the time of sale, to meet all applicable regulations. Kohler Co. also warrants to the initial purchaser and each subsequent purchaser, that the engine is free from defects in materials and workmanship which cause the engine to fail to conform with applicable regulations for a period of two years.

Small off-road engines produced in 1995 or later, and Class 1 LSI engines produced in 2005 and later, are warranted for two years in California. For 1997 and later model years, EPA requires manufacturers to warrant engines for two years in all other states. These warranty periods will begin on the date the engine is purchased by the initial purchaser. If any emission related part on the engine is defective, Kohler Co. will replace the part at no cost to the owner. Kohler Co. is liable for damages to other engine components caused by the failure of a warranted part still under warranty.

Kohler Co. shall remedy warranty defects at any authorized Kohler Co. engine dealer or warranty station. Warranty repair work done at an authorized dealer or warranty station shall be free of charge to the owner if such work determines that a warranted part is defective.

Listed below are the parts covered by the Federal and California Emission Control Systems Warranty. Some parts listed below may require scheduled maintenance and are warranted up to the first scheduled replacement point for that part. The warranted parts are:

- Oxygen sensor (if equipped)
- Intake manifold (if equipped)
- Exhaust manifold (if equipped)
- Catalytic muffler (if equipped)
- Fuel metering valve (if equipped)
- Spark advance module (if equipped)
- Ignition module(s) with high tension lead
- Gaseous fuel regulator (if equipped)
- Electronic control unit (if equipped)
- Carburetor or fuel injection system
- Fuel lines (if equipped)
- Air filter, fuel filter, and spark plugs (only to first scheduled replacement point)

#### LIMITATIONS

This Emission Control Systems Warranty shall not cover any of the following:

- (a) repair or replacement required because of misuse or neglect, improper maintenance, repairs improperly performed or replacements not conforming to Kohler Co. specifications that adversely affect performance and/or durability and alterations or modifications not recommended or approved in writing by Kohler Co.,
- (b) replacement of parts and other services and adjustments necessary for required maintenance at and after the first scheduled replacement point,
- (c) consequential damages such as loss of time, inconvenience, loss of use of the engine or equipment, etc.,
- (d) diagnosis and inspection fees that do not result in eligible warranty service being performed, and
- (e) any add-on or modified part, or malfunction of authorized parts due to the use of add-on or modified parts.

#### MAINTENANCE AND REPAIR REQUIREMENTS

The owner is responsible for the proper use and maintenance of the engine. Kohler Co. recommends that all receipts and records covering the performance of regular maintenance be retained in case questions arise. If the engine is resold during the warranty period, the maintenance records should be transferred to each subsequent owner. Kohler Co. reserves the right to deny warranty coverage if the engine has not been properly maintained; however, Kohler Co. may not deny warranty repairs solely because of the lack of repair maintenance or failure to keep maintenance records.

Normal maintenance, replacement or repair of emission control devices and systems may be performed by any repair establishment or individual; however, **warranty repairs must be performed by a Kohler authorized service center.** Any replacement part or service that is equivalent in performance and durability may be used in non-warranty maintenance or repairs, and shall not reduce the warranty obligations of the engine manufacturer.

# KOHLER<sup>®</sup> ENGINES

FOR SALES AND SERVICE INFORMATION  
IN U.S. AND CANADA, CALL **1-800-544-2444**

KohlerEngines.com

ENGINE DIVISION, KOHLER CO., KOHLER, WISCONSIN 53044

FORM NO.:	24 590 01-A
ISSUED:	11/04
REVISED:	6/07
LITHO IN U.S.A.	



1P24 590 01-A



6 50531 39627 3

MODEL	TYPE	ENGINE	HP	FUEL	CUTTING DEPTH	CUTTING HEIGHT	CUT SWING	NO. TEETH	WHEEL DIA.	WHEEL THICKNESS	TONGUE EXTENSION	WEIGHT (lbs.)
900H	Walk-Behind	Honda	13	Gas	9"	21"	N/A	12	12.25"	.5"	N/A	220
SP2000	Walk-Behind	Kohler	27	Gas	24"	27"	N/A	16	19"	.5"	N/A	695
SP4012	Self-Propelled	Kohler	27	Gas	13"	34"	40" arc	20	21"	1"	30"	1,550
	Self-Propelled	Briggs-Vanguard	35	Gas	13"	34"	40" arc	20	21"	1"	30"	1,650
	Self-Propelled	Kubota	33	Diesel	13"	34"	40" arc	20	21"	1"	30"	1,650
SP7015	Self-Propelled	Deutz Turbo	60	Diesel	15"	43"	70" arc	32	26.5"	1"	N/A	3,500
SP7015TRX	Track-Mounted	Deutz Turbo	60	Diesel	15"	43"	70" arc	32	26.5"	1"	N/A	4,300
SP8018 TRX	Track-Mounted	Deutz Turbo	78	Diesel	18"	43"	80" arc	32	26.5"	1"	N/A	5,420
HURRICANE RS	Track-Mounted	John Deere Turbo	140	Diesel	25"	53"	360°	48	31"	1.5"	N/A	8,500
HURRICANE TRX	Track-Mounted	John Deere Turbo	140	Diesel	25"	72"	360°	64	36"	1.5"	N/A	12,000
	Track-Mounted	John Deere Turbo	175	Diesel	25"	72"	360°	64	36"	1.5"	N/A	12,000
	Track-Mounted	John Deere Turbo	250	Diesel	25"	72"	360°	64	36"	1.5"	N/A	12,000
3500D	Tow-Behind	Deutz Turbo	60	Diesel	15"	40"	80" arc	32	26.5"	1"	48"	2,900
7500	Tow-Behind	Deutz Turbo	78	Diesel	24"	46"	92" arc	48	31"	1.5"	60"	4,400

Call and ask about Carlton's line of Chippers or visit our website: [www.stumpcutters.com](http://www.stumpcutters.com)

**CARLTON—QUALITY PRODUCTS AND EXCEPTIONAL SERVICE**



J.P. Carlton Company Div. DAF, Inc.  
121 John Dodd Road  
Spartanburg, South Carolina 29303  
864-578-9335 • 800-243-9335 • FAX 864-578-0210

Carlton Owner's Manual
660 Disk Chipper
Revised: 10/2008