



Model SP4012

Equipped with a 33HP or 44HP Kubota Diesel Engine

Machine Serial # _____
Engine Model & Spec # _____
Engine Serial # _____
Purchase Date _____
Dealer _____

Carlton

J.P. Carlton Company
Div. D.A.F. Inc.
121 John Dodd Road
Spartanburg, SC 29303
Ph. (864) 578-9335
Fax (864) 578-0210
www.stumpcutters.com

CALIFORNIA

Proposition 65 Warning

Diesel engine exhaust and some of its constituents are known to the State of California to cause cancer, birth defects, and other reproduction harm.

⚠ DANGER

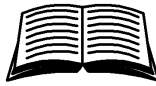

No inexperienced person may operate machine. Inexperience May cause injury.
Read operation manual.

⚠ WARNING

IF THIS EQUIPMENT IS TURNED OVER, YOU WILL CAUSE ENGINE DAMAGE, HYDRAULIC DAMAGE, AND POSSIBLE PERSONAL INJURY.

⚠ WARNING



Loud noise. Flying debris.
Hearing and eye protection must be worn while in operation.

⚠ WARNING



This machine may tip over sideways if operated on non level surface. Always use caution when operating on non-level surface.



DAILY CHECKLIST:

- ✦ Check engine oil. Check with engine sitting level. Add recommended oil (see engine owners manual) as required.
- ✦ Check air filters & precleaners. Inspect dry air cleaners. **DO NOT BLOW OUT OR TAP ON GROUND. REPLACE WITH MANUFACTURER RECOMMENDED AIR FILTER ONLY.**
- ✦ Check fuel filter for debris or water.
- ✦ Replenish fuel tank with fresh fuel.
- ✦ Check condition and tightness of belts.
- ✦ Check for any loose, broken or missing cutter teeth and pockets.
- ✦ Inspect bolts, hydraulic fittings, wiring harnesses, hoses, and equipment for tightness, wear, or leakage. Replace if necessary.
- ✦ Check hydraulic oil level. A sight gauge is located on the tank. Add oil if required.
- ✦ Check condition of tires. Inflate to proper pressure.
- ✦ Grease cutter wheel and jack shaft bearings before and after operation to keep dirt and moisture out. Purge until clean grease is seen.

↑ RIGHT	↑ FWD	↑ DOWN	↑ OUT	↑ LEFT
STEERING TRAVEL	UNIT TRAVEL	CUTTER WHEEL	TONGUE	HOOK TRAVEL
↓ LEFT	↓ REV	↓ UP	↓ IN	↓ RIGHT

⚠ DANGER

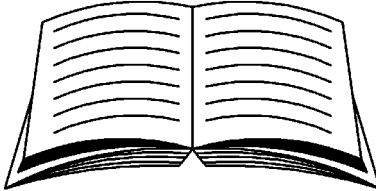

No inexperienced person may operate machine. Inexperience May cause injury.
Read operation manual.

⚠ WARNING

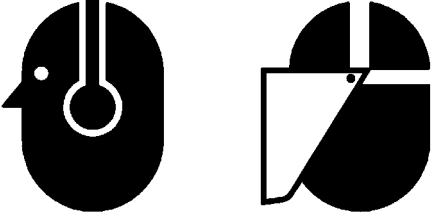

Loud noise. Flying debris.
Hearing and eye protection must be worn while in operation.

 **WARNING**

IF THIS EQUIPMENT IS TURNED OVER, YOU WILL CAUSE ENGINE DAMAGE, HYDRAULIC DAMAGE, AND POSSIBLE PERSONAL INJURY.

 **WARNING**

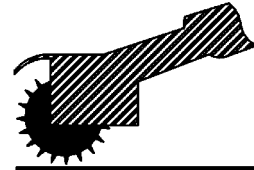

This machine may tip over sideways if operated on non level surface.
Always use caution when operating on non-level surface.

 **DANGER**



Stay clear while machine is in operation.

Cutter wheel will cause severe injury or death.

JPC27

 **DANGER**

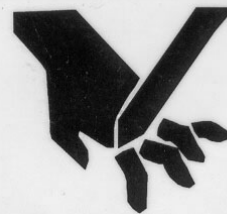

Pinch Points

Keep body parts away while in operation.



JPC09



DANGER

DO NOT MOVE,
POSITION, OR
TRANSPORT THIS
MACHINE WHILE
THE CUTTERWHEEL
IS ENGAGED.

JPC80

	<p>WARNING (AVISO) (AVERTISSEMENT)</p> <p>TO PREVENT SERIOUS INJURY OR DEATH FROM MOVING PARTS: * KEEP HANDS, FEET, AND CLOTHING AWAY FROM MOVING PARTS. * CLOSE ALL GUARDS AND SHIELDS BEFORE OPERATING MACHINERY.</p>
	<p>PARA EVITAR LA LESION O LA MUERTE: * MANTENGANSE A DISTANCIA LAS MANOS, LOS PIES Y LA ROPA DE LAS PARTES MOVIMIENTOS DE LA MAQUINA. * CIERRAN TODAS LAS PROTECTORAS QUE HAY ANTES QUE HAGAN FUNCIONAR.</p> <p>AFIN D'ÉVITER TOUTE BLESSURE GRAVE OU LA MORT: * NE PAS RAPPROCHER LES MAINS, LES PIEDS OU LES VÊTEMENTS DES PIÈCES MOBILES. * S'ASSURER QUE TOUTES LES PIÈCES DE PROTECTION SONT EN PLACE AVANT DE METTRE EN MARCHÉ LA MACHINERIE.</p>

WARNING (AVERTISSEMENT)
(AVISO)

	<ul style="list-style-type: none"> • THREAD FULLY • TIGHTEN NUT
<ul style="list-style-type: none"> • ENROSCAR COMPLETAMENTE • APRETAR TUERCA 	<ul style="list-style-type: none"> • VISSER À FOND • SERRER L'ÉCROU

⚠ WARNING



KEEP AWAY FROM PRESSURIZED LEAKS

Pressurized leaks are not always visible. Check for pressurized leaks using cardboard or wood. Never use a finger, hand or other body part to check for leaks.

Injuries from pressurized leaks penetrating the skin will lead to serious health problems or death. **CONSULT A PHYSICIAN IMMEDIATELY IF PENETRATION OCCURS, SURGICAL REMOVAL REQUIRED.**

Release pressure from line before loosening, removing or replacing any hydraulic hoses or equipment.

0700317

⚠ WARNING

SEVERE ENGINE DAMAGE
WILL OCCUR IF THIS
ENGINE IS OPERATED AT
AN ANGLE GREATER
THAN 25°

PROPER ENGINE OIL LEVEL
MUST BE MAINTAINED TO
ACHIEVE MAXIMUM ANGLE OF
OPERATION OF 25°
(SEE ENGINE OWNER'S MANUAL
FOR PROPER OIL LEVEL)

0700075A

⚠ WARNING



FLAMMABLE FUEL

THIS MACHINE USES DIESEL FUEL AND HYDRAULIC OIL.

NEVER FILL TANK WHILE ENGINE IS HOT, RUNNING, OR IN A CONFINED AREA. DANGER OF FIRE OR EXPLOSION EXIST.

LEAVE ROOM IN THE TANK FOR EXPANSION FROM HEAT - NEVER FILL TANK COMPLETELY FULL.

KEEP MACHINE AWAY FROM FIRE, SPARKS, AND OTHER SOURCES OF IGNITION DURING USE AND STORAGE.

NEVER PUT MACHINE IN STORAGE WITH FUEL IN THE TANK.

ALWAYS STORE FUEL IN APPROVED (RED) CONTAINERS AND AWAY FROM SOURCES OF IGNITION.

0700316

⚠ WARNING

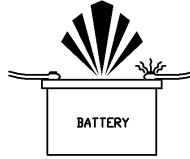

USE CAUTION IN EXTREME COLD! FROZEN BATTERY WILL EXPLODE!

NEVER JUMP START A BATTERY IN FREEZING TEMPERATURES. INSPECT BATTERY FOR SIGNS OF FROST BEFORE STARTING IN EXTREME COLD. MOVE EQUIPMENT TO A HEATED, WELL VENTILATED AREA TO ALLOW BATTERY TO THAW BUT NOT NEAR FIRE, SPARKS, OR OTHER SOURCES OF IGNITION.

BATTERY FUMES ARE EXPLOSIVE. NEVER USE JUMPER CABLES OR RECHARGE BATTERY UNLESS IN AN OPEN OR WELL VENTILATED AREA AND AWAY FROM ALL SOURCES OF IGNITION.

BATTERY ACID CAN CAUSE SEVERE BURNS. KEEP AWAY FROM EYES, SKIN, AND CLOTHING.

ALWAYS REMOVE BATTERY BEFORE WELDING ON EQUIPMENT. FOLLOW PROCEDURES FOR WELDING AND GROUNDING BEFORE STARTING TO WELD ON THIS MACHINE OR EQUIPMENT DAMAGE AND POSSIBLY SEVERE PERSONAL INJURY WILL OCCUR.

0700314

NOTICE

SERVICING BELTS AND BEARINGS

ALWAYS TURN OFF ENGINE AND REMOVE KEY BEFORE SERVICING! ALLOW ALL PARTS TO COME TO A COMPLETE STOP AND COOL BEFORE TOUCHING!

- New belts stretch and get loose. After 2 hours of operation, check tension and tighten belts.
- Check tension and retighten every 4 hours of operation until tension stays consistent.
- See manual for instruction and proper tension.
- Thereafter, check belt tension every month until belts need replacing.

AT LEAST ONCE A MONTH:

- CHECK AND TIGHTEN BOLTS AND LOCK SETSCREWS ON ALL BEARINGS.
- CHECK AND TIGHTEN SCREWS ON ALL BELT PULLEY BUSHINGS.

REFER TO MAINTENANCE SECTION

0700311

NOTICE

Premature engine failure could occur without proper maintenance of outboard bearing. See manual for further information.

JPC

DIESEL MACHINES ONLY

NOTICE

DECALS SHOULD BE PROPERLY MAINTAINED AND REPLACED. IT IS THE DUTY OF THE OWNER OF THIS EQUIPMENT TO KEEP DECALS IN GOOD CONDITION.

REPLACEMENT DECALS MAY BE PURCHASED FROM
J. P. CARLTON CO.

0700309



STUMP GRINDER LIMITED WARRANTY

J.P. Carlton Co. Inc., hereafter referred to as the "Manufacturer", warrants each new Carlton Grinder to be free of defects in workmanship and material for a period of one year.

This warranty takes effect upon delivery to the original retail purchaser. The manufacturer, at its option, will replace or repair, at a point designated by the manufacturer, any parts which appear to have been defective in material or workmanship. The manufacturer is not responsible for consequential damages.

This warranty will not apply if the grinder is not operated in a manner recommended by the manufacturer. The following examples would void warranty:

1. The grinder has been abused.
2. The machine is involved in or damaged by an accident.
3. Repairs or attempted repairs were made without prior written authorization.
4. Including but not limited to repairs made due to normal wear.

The owner is responsible for all regular maintenance as explained in the operators' manual. Neglect in regular maintenance or failure to replace normal wear items such as teeth, pockets, lubrication oils, filters, belts, bearings, etc. may void warranty.

This warranty is expressly in lieu of any other warranties, expressed or implied, including any implied warranty or merchantability of fitness for a particular purpose and of any non-contractual liabilities including product liabilities based upon negligence or strict liability. J.P. Carlton Co. Inc. will not be liable for consequential damages resulting from breach of warranty.

IT IS NECESSARY TO RETURN THE WARRANTY VALIDATION FORM AND NOTIFY J.P. CARLTON CO. INC. IN WRITING WITHIN TEN (10) DAYS FROM DELIVERY DATE TO VALIDATE THIS WARRANTY.

NOTE: This warranty applies only to new and unused equipment or parts thereof manufactured by J.P. Carlton Co. Inc. ANY MACHINES USED FOR LEASE OR RENTAL - WARRANTY IS LIMITED TO 90 DAYS FROM FIRST DAY OF INITIAL SERVICE.

NOTICE: All power units and associated components are NOT warranted by J.P. Carlton Co. Inc. or their dealers. It is the customers' responsibility to return machine to the local engine distributor.

INFORMATION PHONE NUMBERS TO FIND YOUR LOCAL ENGINE & PARTS SERVICE CENTERS:

- Honda 1-770-497-6400 (GA-Eastern Time Zone)
- Kohler Engines..... 1-800-544-2444 (Toll Free)
- Briggs & Stratton Engines..... 1-800-233-3723 (Toll Free)
- Lombardini 1-770-623-3554 (GA-Eastern Time Zone)
- Deutz Engines..... 1-800-241-9886 (Toll Free)
- John Deere Engines 1-800-533-6446 (Toll Free)
- Caterpillar 1-877-636-7658 (Toll Free)
- Kubota 1-847-955-2500 (IL-Central Time Zone)
- Kawasaki Engines..... 1-616-949-6500 (MI-Eastern Time Zone)
- Wisconsin Engines 1-800-932-2858 (Toll Free)
- Onan Engine 1-800-888-6626 (Toll Free)

In order to process any warranty claims, it is the owners' responsibility to report claims promptly to us or our authorized dealer from whom the equipment was purchased. It is necessary to include the following information on any and all request for warranty:

- | | |
|-------------------------------|----------------------------------|
| 1. Dealer from whom purchased | 5. Engine make and serial number |
| 2. Date of delivery | 6. Length of time in use |
| 3. Serial number of unit | 7. Date of failure |
| 4. Model number of unit | 8. Nature of failure |

EXPLANATION OF LIMITED WARRANTY

The manufacturer will not reimburse the customer or dealer labor cost incurred for installing “bolt-on” or “slip-on” items, such as pumps and motors, bearings, belts, pulleys, etc. The manufacturer will provide replacement parts at no cost to the customer for defective parts during the warranty period. Defective parts must be returned to J.P. Carlton Company. It will be the customers’ responsibility to install the replacement parts unless arrangements are made with the selling dealer.

The manufacturer will not reimburse travel cost to servicing dealer. It is the customers’ responsibility to deliver machine to dealers facility, unless other arrangements have been agreed to between the selling dealer and the customer.

The manufacturer may elect, at its discretion, to reimburse reasonable labor cost to customer or dealer for major defect repairs. Prior approval must be obtained from J.P. Carlton Company Inc.

IMPORTANT NOTICE

- 1. AIR FILTER MAINTENANCE IS CRITICAL ON STUMP GRINDING MACHINES. DIRT INGESTION WILL NOT BE WARRANTED BY THE ENGINE MANUFACTURER OR J.P. CARLTON COMPANY.**
- 2. OIL AND OIL FILTER MAINTENANCE AND STAYING WITHIN THE LIMITS OF THE ANGLE OF OPERATION IS ALSO CRITICAL ON STUMP GRINDING MACHINES. STARVING THE ENGINE FOR OIL WILL NOT BE WARRANTED BY THE ENGINE MANUFACTURER OR J.P. CARLTON COMPANY.**

Warranty Validation Form

Congratulations on your purchase of a Carlton Stump Grinder. This product has been designed and manufactured to provide years of profitable service while minimizing maintenance and downtime. Please take the time now to complete this warranty validation form. This information is necessary for Carlton to instate your warranty.

Return Form To: J.P. Carlton Company, Div. D.A.F. Inc.
121 John Dodd Road
Spartanburg, SC 29303
Phone: 1-864-578-9335

Purchaser Information:

Company Name: _____ Street Address: _____
City: _____ State: _____ Zip Code: _____
Telephone: _____ Contact: _____

Machine Information:

Model Number : _____ Engine Model : _____
Serial Number : _____ Serial Number : _____

Dealer Information:

Dealer Name: _____ Street Address: _____
City: _____ State: _____ Zip Code: _____
Contact Name: _____

1. _____ Customer has been instructed on operation and safety aspects of operating the equipment.
2. _____ Customer has been advised not to reach into cutter wheel area.
3. _____ Customer has been advised to stop machine and remove key before performing any type of maintenance.
4. _____ Customer has been warned not to operate the machine without the cutter wheel guard in place.
5. _____ Customer has been furnished with all parts and operators manuals.
6. _____ Customer has been instructed on equipment maintenance schedules and procedures.
7. _____ Customer has been advise that the engine or power unit that is used on this machine is warranted by the engine manufacturer and ***NOT J.P. Carlton Company***. All engine warranty issues should be addressed to the local engine dealer.
8. _____ Customer understands the importance of air and oil filter maintenance, and the importance of staying within the angle of operation of the engine. If either of these is not adhered to, the engine warranty is ***VOID***.
9. _____ Customer understands to keep locking collars tight and purge bearings with grease.
10. _____ All operation and warning decals are properly displayed on equipment.
11. _____ Customer understands it is his responsibility to train all operators on operator safety.

I have inspected this equipment and find it in good working condition. To the best of my knowledge, the customer and his personnel are aware of the above procedures.

Date: _____ Signed: _____
Dealer Representative

The equipment has been thoroughly checked by the above named dealer representative, and I am satisfied with his instructions.

Date: _____ Signed: _____
Purchaser

INTRODUCTION

FOREWORD	1
GENERAL INFORMATION	2
MACHINE FEATURES	3
MACHINE SPECIFICATIONS	4

OPERATION

SAFETY PRECAUTIONS	5
DAILY CHECKLIST	9
MACHINE CONTROLS	10
TRANSPORTING	21
MACHINE OPERATION	23

MAINTENANCE

MACHINE MAINTENANCE	26
LUBRICATION CHART	31
TROUBLE SHOOTING GUIDE	32
SERVICING BELTS	34
SERVICING BEARINGS	41
SERVICING FRONT AXLE	49
SERVICING BOOM PIVOT	50
SERVICING CUTTER WHEEL	51
SERVICING STUB SHAFT	56
SERVICING HYDRAULICS	62
MACHINE WIRING	66

PARTS

HYDRAULIC ASSEMBLY	70
FRONT AXLE ASSEMBLY	83
REAR WHEEL ASSEMBLY	87
PIVOT ASSEMBLY	89
BOOM ASSEMBLY	92
CHIP GUARD ASSEMBLY	102
BACK	
RADIO CONTROL MANUAL	



Congratulations on your purchase of a new Carlton® Professional Stump Grinder! Carlton® Stump Grinders have a reputation for superior performance and reliability. A machine is not profitable if it's broken-down and we do our absolute *best* to help you avoid costly downtime. Each and every machine has been *over* designed and overbuilt to ensure years and years of trouble-free operation. In this, we take pride.

The Carlton® Model SP4012 Diesel is designed and intended to be used in unique situations where size and maneuverability are foremost. As a result, the Model SP4012 Diesel has it's own unique operational requirements.

Read this manual carefully and **TAKE RESPONSIBILITY** for thoroughly familiarizing yourself with the controls and the concepts behind the operation of this machine before attempting to operate it. Slowly experiment with the controls and gradually work yourself up to the full capabilities of this machine. The Carlton® Model SP4012 Diesel is a durable and profitable professional stump grinder. Read this manual. Use proper safety precautions. Follow the instructions given and use common sense and your "OX" will perform like its namesake. If getting more work done in a day, with less trouble, is your idea of good business, then you'll *love* your new Carlton® Stump Grinder!

We welcome your suggestions on how we might better build our machines. We solicit any and all questions concerning the safe operation or proper servicing of your new stump grinder.

Please feel free to write to us with any comments.
We'll enjoy hearing from you!

The J. P. Carlton Company constantly strives to create the best equipment available in the stump cutting industry. Therefore, the material in this manual is correct at the time of publication. Carlton® reserves the right to make improvements, modifications and even discontinue features, as we deem necessary to meet our goal. Carlton® also reserves the right to discontinue models without any prior notification or obligation.

Inspect your new Carlton® Stump Grinder as soon as you receive it. Any damages incurred during shipment are not warranted and therefore not covered repairs. You should have the truck driver verify or acknowledge any damages caused during shipment. If not, contact the truck lines as soon as possible with your complaint.

Any reference made to right, left, front or rear in relationship to the stump cutter is illustrated in the following picture. Please refer to these any time you call your dealer or J. P. Carlton Company for parts or assistance.





- Direct drive hydraulic pump
- 4-wheel hydraulic motor propulsion
- Hydraulic controls
- Freewheeling capability
- Safety valves permit unaffected operation uphill, downhill or level
- Heavy construction
- Counterbalancing valve
- Dual swing cylinders
- Hardened bushings in rotating cylinders
- Four wheel stance
- Hydraulic steering
- Diesel engine
- Adjustable Timken tapered roller bearings in the pivot head with hardened shafts
- Tapered roller bearings on cutter wheel & jackshaft
- 1" thick Blanchard ground cutter wheel
- 20 carbide tipped cutter teeth
- 35" width to clear narrow fence gates
- Double wire braid hose & hydraulic lines
- Safety tie down loops
- 1/4" plate fenders
- Epoxy primer
- DuPont Imron® protective finish
- Key start
- High capacity battery
- Premium tires
- Heavy duty rubber and metal chip guards
- Hour meter
- Large hydraulic tank
- Hydraulic and fuel filters
- Removable chip flap
- Poly Chain® Belt to cutter wheel
- Easy engine belt adjustment
- Scrape Blade

**We Pride Ourselves
in the strength and quality of each and every machine**

Engine.....	Kubota 33HP
Weight	1650 Lbs.
Length.....	8'6"
Height	46"
Width.....	35"
Cutting Depth Below Ground	13"
Cutting Height Above Ground	34"
Cutter head Swing	40" Arc
Number of Teeth on Cutter Wheel	20
Cutter Wheel Diameter w/Teeth	21"
Cutter Wheel Thickness	1" Blanchard Ground
Jackshaft Bearings.....	1 11/16"
Cutter Wheel Bearings	1 11/16"
Cutter Wheel Speed.....	1350 RPM
Fuel Tank Capacity	10.3 Gallons
Hydraulic Tank Capacity	3.6 Gallons

Before operating the stump cutter, read this manual, the engine manual, and all the safety decals on the machine. Know all parts of the machine and their functions, especially the shut down procedures in case of emergency. No inexperienced person may operate machine. Inexperience may cause injury.

SAFETY FIRST ALWAYS!

This is the **Safety-Alert Symbol**. This symbol is placed on the machine and in the manual to alert the operator to the potential for bodily injury or death. The operator should pay close attention to the instructions whenever they see this symbol.



The **Safety-Alert Symbol** will be accompanied by one of the following words:

DANGER, WARNING, or CAUTION

- A **DANGER** symbol means that if the instructions are not followed the possibility of serious personal injury or death is probable.
- A **WARNING** symbol means that if the instructions are not followed there is a possibility of serious personal injury or death.
- A **CAUTION** symbol means there is an unsafe condition or practice that may cause personal injury or property damage.

PERSONAL PROTECTION:

- ❖ Wear face shield and hearing protection
- ❖ Do not wear loose-fitting clothing
- ❖ Tie back long hair
- ❖ Do not wear jewelry
- ❖ Keep clear of cutter wheel
- ❖ Keep away from moving parts
- ❖ Only operate in a well ventilated area because of carbon monoxide

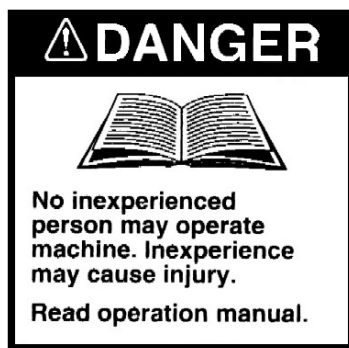
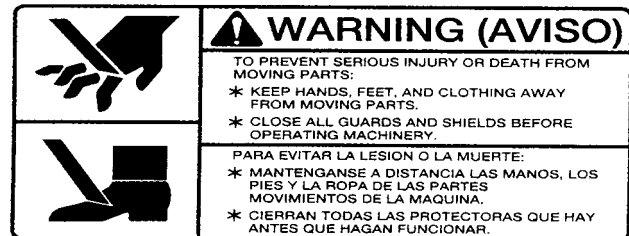

P/N 0700008



P/N 0700010



P/N 0700027

Be Safe and Practice Safe Operation using the following guidelines.



- Any individual operating this machine must first read and understand this manual, the engine manual and all safety decals on machine.
- DO NOT permit children to operate machinery or to play near machinery during operation.
- Always wear face shield and hearing protection during operation. Loud noise and flying debris may cause severe injury.
- Keep hands, feet, legs, clothing, hair and all other body parts away from cutter wheel and other moving machine parts to eliminate the possibility of injury.
- Shut down machine completely and remove key before removing debris from work area (i.e. clearing rocks, wood chips, etc.).
- DO NOT modify or change any part without written approval from J. P. Carlton Company.
- Do not ride, sit, stand, lay or climb anywhere on this machine during operation, while running, or during transport.
- Do not move, position, or transport this machine while cutter wheel is engaged.

- Do not refill fuel tank while engine is hot, running, or indoors. Danger of fire or explosion exists.
- Fuel and its vapors are highly flammable and explosive. **Handle with care.** Only use approved (red) fuel containers for storage.
- Do not store fuel containers near any open flames, sparks or other sources of ignition.
- Do not store equipment with fuel in the tank.

- Battery fumes are explosive. Recharge battery in an open area away from fire, sparks, or other sources of ignition.
- Battery acid can cause severe burns. Keep away from eyes, skin, and clothing.
- Always remove battery before welding on equipment.

- **DO NOT OPERATE THE ENGINE AT AN ANGLE GREATER THAN 25° OR SEVERE ENGINE DAMAGE WILL OCCUR. PROPER ENGINE OIL LEVEL MUST BE MAINTAINED TO ACHIEVE MAXIMUM ANGLE OF OPERATION OF 25°. (See Engine Owner's Manual for proper oil level.)**





- Never allow spectators to stand and watch machine in operation without proper hearing and eye protection and standing at a safe distance. Loud noise and flying debris may cause severe injury.
- Do not operate around water, gas, power or phone lines. Check with property owner or call utilities if not sure.
- Avoid fences and clear away other objects (i.e. sticks, stones, metal, etc.).
- Be aware of the possibility of foreign objects imbedded in or buried around the stump. Do not cut crosswise of roots above ground to prevent roots being thrown.
- If unusual vibration occurs, stop engine immediately and correct problem before continuing operation.
- Keep all guards in place and properly secured during operation.
- Keep all safety devices working properly and all other machine parts in good working condition.
- Never leave the controls unattended while in operation. Be sure machine is not capable of operation when left unattended.



- Stop engine and remove key when repairing or adjusting machine or drive belts.
- Keep engine in good condition service as instructed in engine manual.
- Do not touch engine while running or hot (serious burns may result).
- Allow all machine parts to cool sufficiently before servicing or making adjustments. Hot machine parts can cause severe burns.



- Do not run the machine without a complete number of teeth in the cutter wheel tightened to the correct torque.
- Do not place machine in free wheel without first placing tongue stake in the ground.
- Park machine on level surfaces only. Lower cutter head to the ground and use wheel chocks to prevent unattended movement.



- Do not operate stump cutter in dark, dim lit, or concealed areas.
- Keep machine clean and clear of debris to eliminate fire hazard.
- Keep cutter wheel skirt guards in good condition to help control chips during grinding.
- Keep safety and instructional decals clean and replace any that are damaged, difficult to read, or missing.

ATTENTION:

The Carlton® Model SP4012 Diesel Stump Grinder CAN be overturned on steep inclines. This can cause serious injury to operator and machine. **DO NOT OVERTURN!**



P/N 0700024

1. Avoid steep side inclines when operating this machine! The narrow design width required in operating the model SP4012 Diesel in tight confines makes it susceptible to tipping over sideways. Overturning this machine can result in personal injury, property damage and/or seizing the engine.
USE CAUTION.

- Positioning the **cutter wheel uphill** and as close to the ground as possible while in transit will minimize the danger of tipping over and maximize the steadiness of the Model SP4012 Diesel.
- When encountering a hill, the best approach is straight up or straight down. Avoid any side angles whenever possible.
NEVER ALLOW INEXPERIENCED PERSONS TO OPERATE THIS MACHINE.

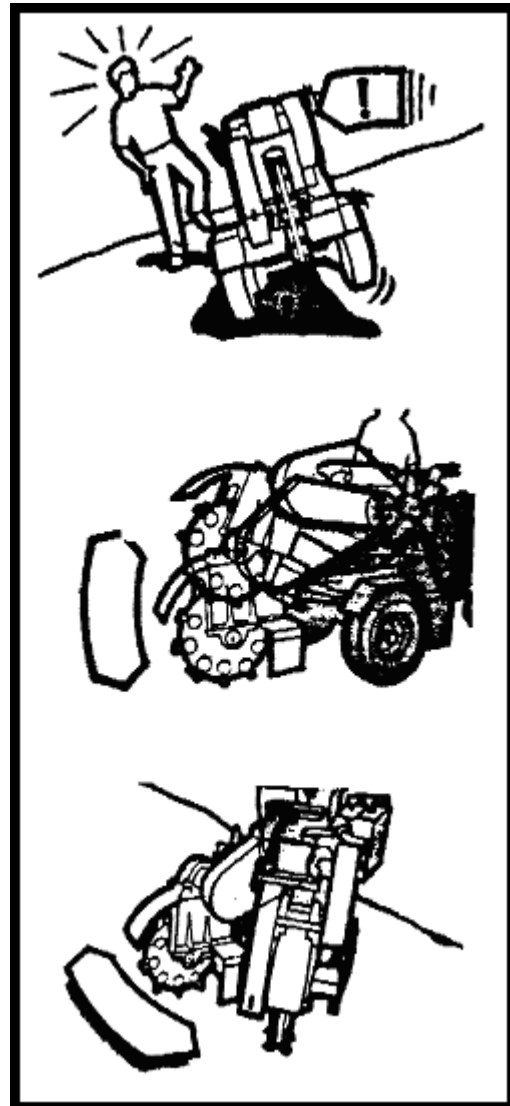

- Check engine oil at dipstick. Take reading with engine sitting level (see photos). Add recommended oil as required (see engine owners' manual).
- Check fuel filter for debris or water.
- Replenish fuel tank with fresh fuel.
- Check hydraulic oil **daily**, with engine off and cool, and replenish as necessary. This Carlton stump grinder is equipped with a gauge that shows the level of oil and the temperature of the oil. When filling the tank with oil, the window of the gauge will also fill with oil, as the level gets higher in the tank. Never fill the oil tank above the **BLACK** line at the top of the gauge. Do not run the machine with the oil level below the **RED** line at the bottom of the gauge.
- Check air filters & pre-cleaners. Inspect dry air cleaners. Do not blow out or tap on ground. **REPLACE WITH MANUFACTURER RECOMMENDED AIR FILTER ONLY**
- Check condition and tightness of engine belts. (See Servicing Belts section) New belts will stretch and become loose as machine runs. Check belt tension often when belts are new.
- Check for any loose, broken or missing cutter teeth and pockets.
- Grease cutter wheel and jackshaft bearings daily. Purge bearings until new grease is seen.
- Inspect bolts, hydraulic fittings, wiring harnesses, hoses and equipment for tightness, wear, or leakage. Replace if necessary.
- Check condition of tires. Inflate to proper pressure.



INCORRECT POSITION



CORRECT POSITION



OIL LEVEL/TEMP GAUGE



PURGE CUTTER WHEEL AND JACKSHAFT BEARINGS DAILY WITH GREASE



ENGINE CONTROLS - Refer to engine manufacturers owners' manual for controls, operation, and service.

- On the manually operated Kubota machine, the **Key Switch** for starting the engine is located on the control panel. Press the by-pass switch and turn the key to the right to start the engine.
- There is a pre-heat function on this engine. To pre-heat before starting, turn the key switch to the left and hold it for 5-10 seconds and then start the engine. **DO NOT** hold longer than 20 seconds.
- Read the engine manual for proper starting and operating instructions.
- **CUTTER WHEEL MUST BE DISENGAGED WHEN STARTING THE MACHINE.**
- The throttle lever for this machine is on the side of the control box as shown at the right.
- The control panel for the Kubota engine has sensor lights for the alternator, water temperature, and oil pressure. Monitor these lights and make the necessary adjustments as described in the engine owner's manual.

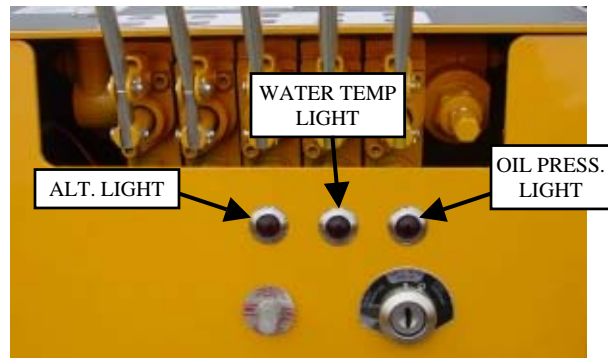
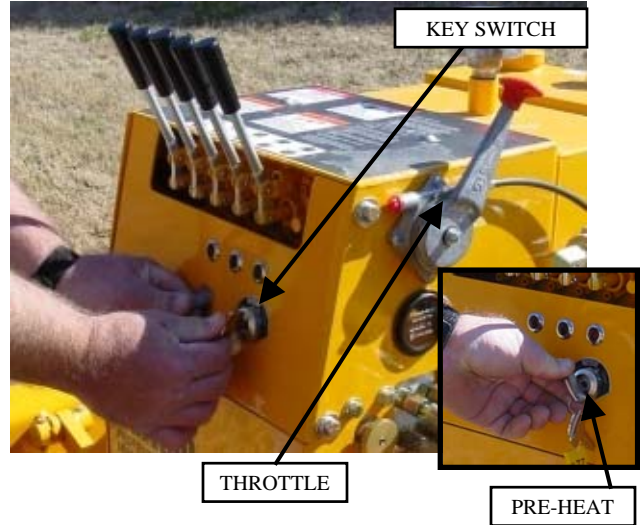

DO NOT OPERATE THE ENGINE AT AN ANGLE GREATER THAN 25° OR SEVERE ENGINE DAMAGE WILL OCCUR. PROPER ENGINE OIL LEVEL MUST BE MAINTAINED TO ACHIEVE MAXIMUM ANGLE OF OPERATION OF 25°. (See Engine Owner's Manual for proper oil level.)

HYDRAULIC CONTROLS

- A series of hydraulic controls are located on the machine and are clearly marked.

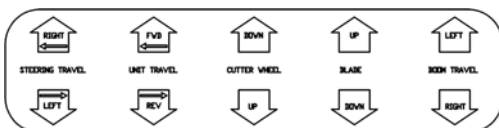

STEERING TRAVEL - (lever 1)

- Push or pull control lever to control steering, right or left.



UNIT TRAVEL - (lever 2)

- Push or pull control lever to control travel, forward or reverse. This lever controls the four drive motors on the front and rear wheels.



DRIVE MOTORS FRONT AND REAR



CUTTER WHEEL (Lift) - (lever 3)

(Shown as CUTTER HEAD –UP/DOWN on radio transmitter.)

- This lever operates the cutter head lift function, which raises and lowers the cutter head.



BLADE - (lever 4)

- This lever operates the blade function, which moves the scrape blade up and down. To backfill the hole after grinding the stump, lower the scrape blade by pulling the lever back. At all other times keep the scrape in the raised position.



BOOM TRAVEL (Swing) - (lever 5)
(Shown as CUTTER HEAD –RIGHT/LEFT on radio transmitter.)

- This lever operates the cutter head swing function, which swings the boom back and forth in a left-right-left-right-left... motion.



CUTTER WHEEL ENGAGEMENT LEVER

- **Never start engine with cutter wheel engaged.** With engine at idle, raise the engine slide lock, and slowly move the engagement lever towards the front of the machine to engage drive belt. **DO NOT ENGAGE OR DISENGAGE BELT AT HIGH ENGINE SPEED. Injury and damage will occur.**



ENGINE SLIDE LOCK

- Unlock the engine slide lock brace and raise the engine slide lock handle. This will unlock the engine slide and allow you to engage the cutter wheel.

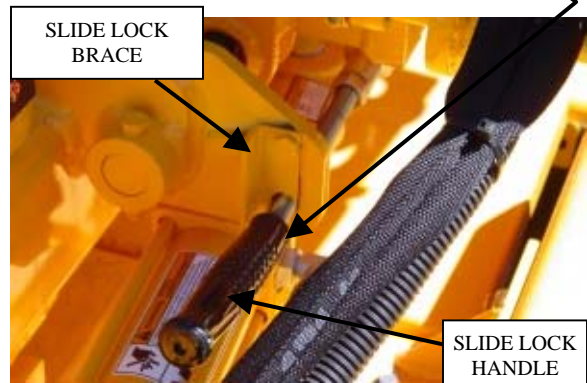



GEAR SELECTOR

- Push switch up to run machine at high gear and push switch down to run machine at low gear. Machine has more climbing power in low gear. **MUST BE IN HIGH GEAR TO CHANGE INTO FREEWHEEL.**

FREEWHEELING VALVE

- Releases wheels from the drive system by overriding the hydraulics. To engage, push knob in and turn a quarter turn counter-clockwise. To disengage freewheel, push knob in and turn clockwise back to original position. Knob will pop out when freewheeling is disengaged. **FREEWHEEL WILL ONLY OPERATE WITH GEAR SELECTOR IN THE HIGH POSITION.**

TRAVEL SPEED ADJUSTMENT

- Adjust travel speed for smooth operation. Turn valve counter-clockwise to decrease travel speed.

SWING SPEED ADJUSTMENT

- Adjust swing speed for smooth operation. Turn valve counter-clockwise to slow cutter head swing. Close valve by turning clockwise to allow head to move side to side at low RPM.



OPTIONAL 2-WHEEL DRIVE AND TONGUE EXTENSION FUNCTIONS

This machine can be ordered with two-wheel drive and tongue functions instead of four-wheel drive and a blade. These functions are standard on other SP4012 stump grinders.



STEERING TRAVEL - (lever 1)

- Push or pull control lever to control steering, right or left. The steering travel function operates in the same manner but the machine will look slightly different, as shown in the picture to the right.



UNIT TRAVEL - (lever 2)

- Push or pull control lever to control travel, forward or reverse. The travel function operates the same except there are only the drive motors on the rear of the machine.



TONGUE - (lever 4)

- This lever operates the tongue extension function, which moves the machine toward the stump and pulls the machine back away from the stump. To operate the tongue extension set freewheel valve to freewheeling position (see complete information earlier in this section). **Always make sure that the ground stake is in the ground before placing machine in free wheel.**



GROUND STAKE

- Pushed firmly into the ground, the stake anchors the machine against pressure during cutting. Provides a “push point” for tongue extension. **Ground stake must be used during operation. The hydraulic motor will not keep machine from creeping while grinding stump.** After stake is in ground, place machine in freewheel position.



OPTIONAL REMOTE CONTROL

OPERATION – WIRED

- For remote operation, the **Key Switch** for starting the engine is located on the front side of the control panel. Read the engine manual for proper starting and operating instructions.
- **CUTTER WHEEL MUST BE DISENGAGED WHEN STARTING THE MACHINE.**
- The control functions operate the same on a remote control machine as they do on a standard machine. Instead of having the machine mounted control levers as described earlier in this section, there are toggle switches on the machine control box and on the remote control unit. The toggle switches on the machine control panel can be used to operate the machine for short-term operation to position the machine or to test the operation of the functions.
- Use the switches on the remote transmitter to operate the machine when moving the machine to the job site and when grinding the stumps. For a remote control machine with a wired remote transmitter, turn the **Machine ON/Remote ON** switch to **Remote On** and turn the **Engine** switch on the transmitter to **RUN**. Now start the engine using the key switch, run the engine a few minutes to allow the oil to circulate before starting to operate the functions. After the engine has been running for a few minutes, test the remote transmitter by testing the functions for correct operation. After testing the functions and everything is operating correctly, proceed to the job site.

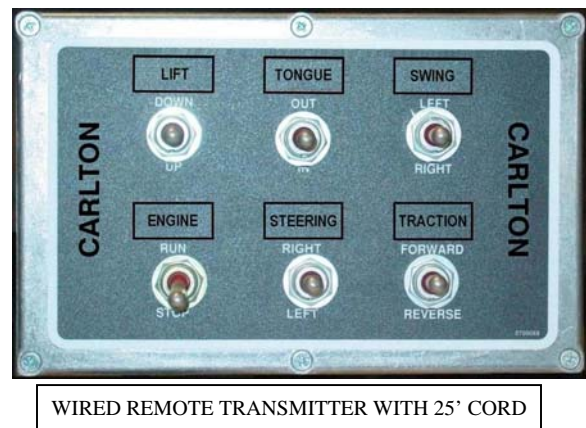
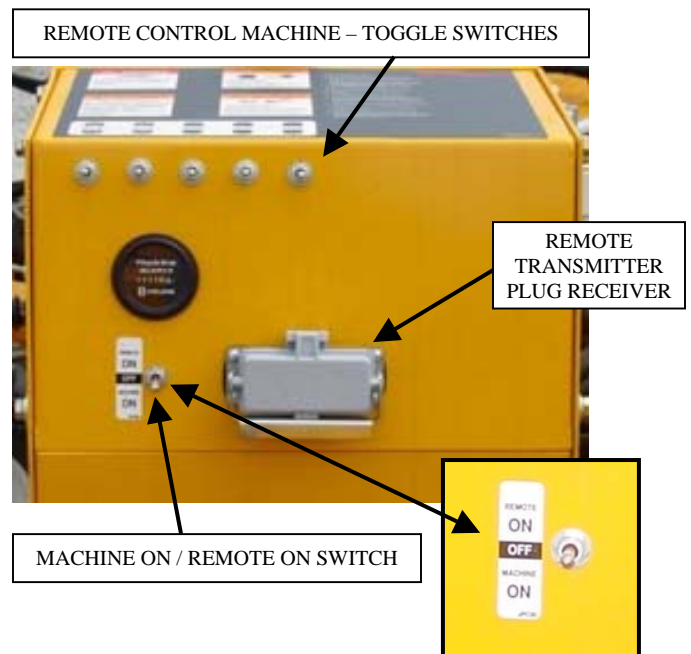

- Some functions require using the machine mounted controls, such as the Swing Speed Adjustment Valve, the Ground Speed Adjustment Valve, the Freewheel Valve on machines equipped with freewheel motion, and the Engagement Lever to engage the cutter wheel. The Swing Speed Adjustment, Freewheel, and Ground Speed Adjustment Valves are on opposite sides of the machine from the standard machine but still operate the same.

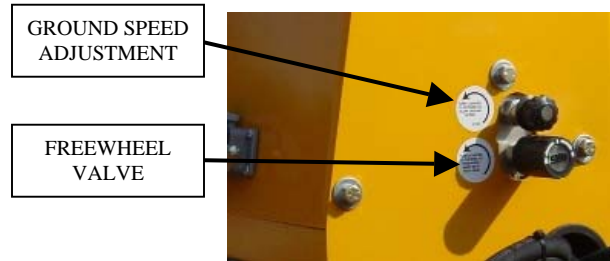
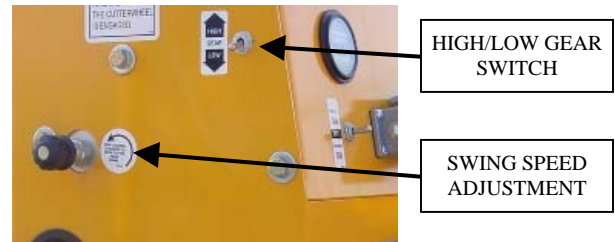

SAFETY

- **NEVER SERVICE A MACHINE WITH THE ENGINE RUNNING, SEVERE PERSONAL INJURY COULD OCCUR. TURN ENGINE OFF THEN REMOVE IGNITION KEY AND DISCONNECT POSITIVE BATTERY CABLE TO AVOID STARTING MACHINE ACCIDENTALLY.**
- **CUTTER WHEEL MUST BE DISENGAGED BEFORE TURNING ENGINE ON/OFF AND BEFORE SERVICING A MACHINE. OTHERWISE SEVERE PERSONAL INJURY COULD OCCUR AS WELL AS MACHINE DAMAGE.**
- **ALL MACHINE PARTS MUST COME TO A COMPLETE STOP AND HAVE TIME TO COOL COMPLETELY BEFORE SERVICING A MACHINE OR SEVERE INJURY COULD OCCUR, POSSIBLY SERIOUS BURNS AND/OR DISMEMBERMENT.**
- **PLACE THE CUTTER WHEEL ON THE GROUND WHEN PERFORMING SERVICE ON A MACHINE.**

OPTIONAL REMOTE CONTROL

CONVERTING FROM WIRED TO RADIO TRANSMITTER

- To change from a wired to a radio (wireless) transmitter, remove the lower cover on the control box. There are 2 bolts on each side.
- You can now see the wired remote control receiver. Remove the receiver cover. Drill holes in this cover for attaching the radio control receiver; make sure the hole locations match the bolt locations on the radio receiver.
- Bolt the radio receiver to the cover and then replace the cover on the wired remote receiver inside the control box.
- Use the wiring and connector diagrams, in the radio control manual included at the back of this manual, to wire directly to the appropriate contacts of the machine electronics. Contact your Carlton dealer if you need assistance not the radio control manufacturer.
- The radio transmitter and receiver will be programmed at the factory when purchased as a set.



REMOVE THE CONTROL BOX BOTTOM COVER



REMOVE THE COVER ON THE REMOTE RECEIVER AND DRILL HOLES TO ATTACH THE RADIO RECEIVER



THE RADIO CONTROL RECEIVER, SHOWN AT THE RIGHT, MUST BE INSTALLED IN THE CONTROL BOX



OPERATION – WIRELESS

- THE CUTTER WHEEL MUST BE DISENGAGED BEFORE STARTING THE MACHINE.
- To start the engine and radio control transmitter, follow these instructions.
- On the machine, turn the ignition key switch to ON (see engine picture below right), the machine switch to **Remote On**, and make sure the Gear switch is in the HIGH position.
- On the transmitter, press the **E-STOP** button down.
- Toggle any switch on the transmitter.
- Twist the **E-STOP** button clockwise to release. Release the E-STOP button within 10 seconds to power up or the unit will power down. When the transmitter is operating there is a yellow light that will be flashing, the light is indicated in the picture at the right. (Read the radio control manual for more information on the meaning of different lights and colors.) If the transmitter doesn't start, check the transmitter for stuck switches, it will not start with a switch in the ON position.
- Now start the engine, turn the key switch while pressing the by-pass switch to start the machine. If the engine doesn't start right away and you have to restart it, turn the key switch OFF and back ON. Make sure the light on the transmitter is still on, and restart the engine by turning the key and pressing the by-pass switch. If you lose the connection (light off), repeat the procedure from the beginning and perform each step exactly as described. Test controls for proper operation.
- The E-STOP button turns off the transmitter and the machine when it is pressed down.
- When the transmitter Gear switch is toggled up to HIGH, it only operates when the Travel function is being used.

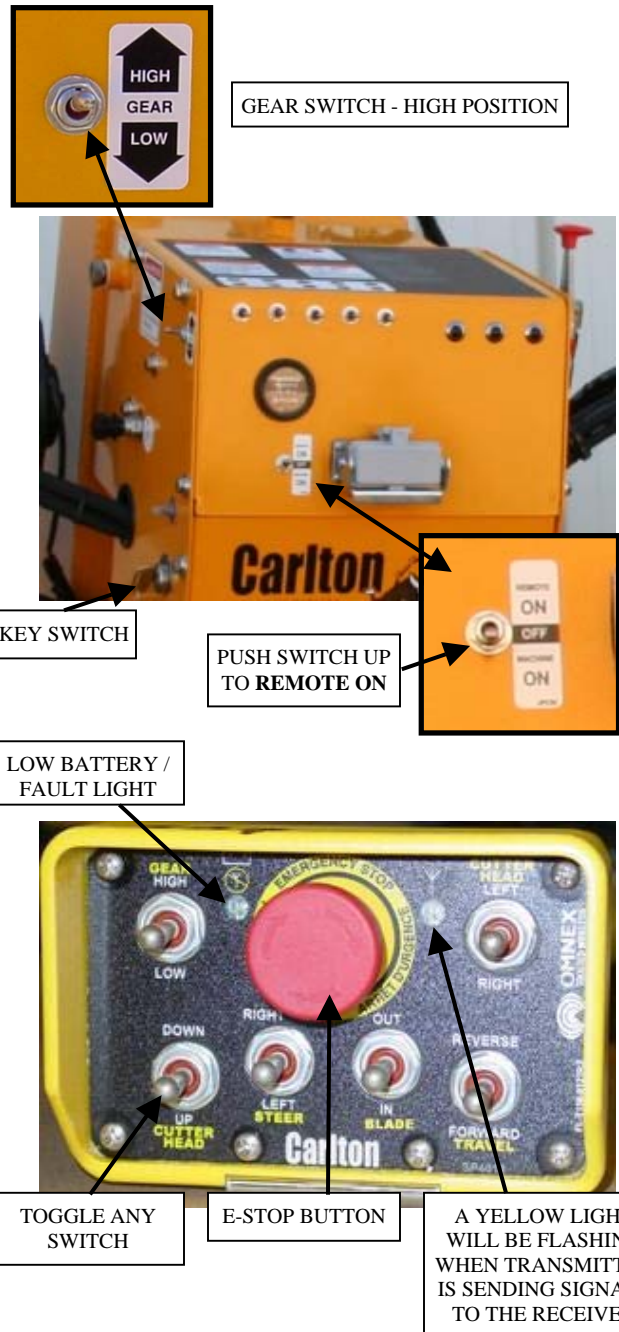

NEVER WELD ON A MACHINE WITH RADIO CONTROLS WITHOUT FIRST DISCONNECTING THE RECEIVER WIRE HARNESS, OTHERWISE THE RADIO RECEIVER WILL BE DESTROYED.

OPTIONAL REMOTE CONTROL

PROGRAMMING – WIRELESS

- If there is a problem with the receiver or the transmitter and either has to be replaced, you will need to program the new unit to communicate with the existing unit. Or if you have more than one transmitter for this machine, it will need to be programmed to communicate with the existing receiver.
- To program the transmitter and receiver, you have to download the transmitter's unique code into the receiver. There are complete instructions along with colored illustrations in the radio control manual included in the back of this manual.
- To access the receiver, remove the front cover from the machine control box.
- Remove the cover of the remote receiver with the radio receiver attached. This will make it easier to work with the radio receiver. Remove the radio receiver panel by unlatching the plastic tabs on either side of the receiver; see the radio control manual in this manual at the back. The receiver panel will now slide out of the cap.
- Follow the instructions in the radio control manual to download the ID Code. There are specific instructions that need to be followed and corresponding illustrations. The radio control manual is included in the back of this manual.
- Push the receiver panel back up into the cap until the tabs snap back into place.
- Always replace the machine cover when maintenance or troubleshooting is complete. **DO NOT RUN MACHINE WITHOUT ALL GUARDS & COVERS IN PLACE AND SECURED.**



REMOVE COVER



RELEASE THE RADIO RECEIVER CAP BY UNLATCHING THE TABS ON EACH SIDE

REMOVE THE REMOTE COVER TO ACCESS THE RADIO RECEIVER UNIT

TROUBLESHOOTING

SEE THE RADIO CONTROL MANUAL FOR ANY OPERATING PROBLEMS WITH THE RADIO RECEIVER & TRANSMITTER

(Included in the back of this manual)

- First check the batteries to make sure they are providing enough power to operate the transmitter.
- There is a low battery light on the transmitter, when it starts flashing you have approximately 10 hours of operation left.
- Remove the back cover on the transmitter. Remove old batteries and replace with new batteries. The transmitter operates using 4 AA alkaline batteries.
- Next, open the cover on the machine control box. You will need to be able to see the lights on the receiver to compare to the trouble indicators on the receiver diagnostic list in the radio control manual. Check the light configuration and compare it to the Receiver Diagnostic list in the radio control manual.
- If status light on radio receiver is flashing red, a fuse is blown. To change a fuse, remove the receiver panel from the cap and change the fuse. Inspect wiring for short circuits (e.g. bare wires). If problem re-occurs, call for service. Push the receiver panel back up into the cap until the tabs snap back into place.
- Always replace the machine cover when maintenance or troubleshooting is complete. **DO NOT RUN MACHINE WITHOUT ALL GUARDS & COVERS IN PLACE AND SECURED.**

LOW BATTERY LIGHT



REMOVE THE BACK COVER TO ACCESS THE BATTERIES – THERE ARE 4 SCREWS HOLDING IT IN PLACE. THE BATTERY COMPARTMENT IS LABELED FOR CORRECT BATTERY ORIENTATION.



REMOVE COVER



COMPARE THE LIGHT CONFIGURATION ON THE RECEIVER TO THE DIAGNOSTIC CHART IN THE RADIO CONTROL MANUAL



REPLACE FUSE

DO NOT TOW! THE MODEL SP4012 DIESEL IS DESIGNED TO BE TRANSPORTED TO THE JOB SITE AND WILL MOVE UNDER ITS OWN POWER ONCE ON SITE.

Transport machine in a suitable vehicle designed for a load of these dimensions and weight. A low trailer is recommended due to its decreased entry height, and will be safer all around. Always use safety tie down straps while transporting.

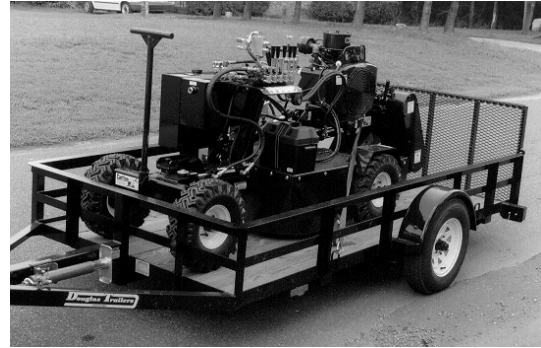

The model SP4012 Diesel can be loaded into a pick-up truck, but requires increased safety precautions against tipping. Tie-downs, a sturdy and stable loading ramp and extra caution are required.

- **LOADING RAMPS MUST BE STURDY AND ATTACHED TO THE TRANSPORT VEHICLE BEFORE ATTEMPTING TO LOAD\UNLOAD THIS MACHINE.**
- **TRAILER MUST BE SECURELY ATTACHED TO TOW VEHICLE BEFORE LOADING OR UNLOADING THE STUMP GRINDER.**
- Check trailer for security and make sure chains are properly installed.
- Check tires inflation.
- Check towing lights for proper operation
- Never transport with machine motor running.
- Towing will affect handling. Allow for extra stopping distances.
- Start and stop gradually.
- Tow at a safe reasonable speed. Obey posted speed limits.

LOADING

- **TRAILER MUST BE SECURELY ATTACHED TO TOW VEHICLE BEFORE LOADING OR UNLOADING THE STUMP GRINDER.**
- **DO NOT LOAD OR UNLOAD ON ANYTHING OTHER THAN LEVEL GROUND.**
- Check valve to make sure machine is **NOT** in freewheeling mode. (See Machine Controls section for more information on freewheeling operation.)
- Start engine as recommended by the engine manufacturers manual.
- Increase engine RPM, and raise cutter head just off the ground.
- With operator in position, push the forward travel control lever and steer machine slowly up appropriate ramp into transport vehicle. **KEEP MACHINE AS LEVEL AS POSSIBLE.**
- Continually adjust cutter head height as you go, keeping the mass as low to the ground as possible.
- Once the machine is loaded, lower the cutter head, shut down engine and secure machine tightly with sufficient tie-downs to prevent any movement in transit.

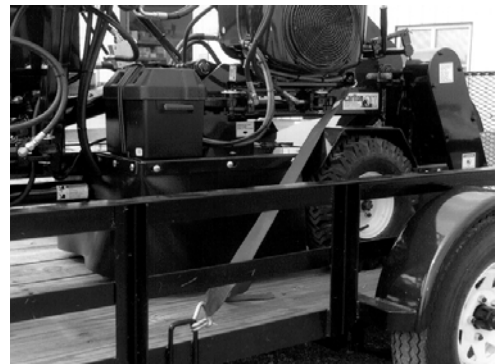

UNLOADING

- **TRAILER MUST BE SECURELY ATTACHED TO TOW VEHICLE BEFORE LOADING OR UNLOADING THE STUMP GRINDER.**
- **DO NOT LOAD OR UNLOAD ON ANYTHING OTHER THAN LEVEL GROUND.**
- Freewheeling valve **MUST** be in “drive” position to avoid machine runaway on ramp. (See Machine Controls section for more information on freewheeling operation.)
- Undo tie down straps and check ramps for sturdiness and positioning.
- Start engine as recommended by the engine manufacturers manual.
- Increase engine RPM, and raise cutter head to just clear deck and/or ramp.
- Continually adjust cutter head height as you go, keeping the mass as low to the ground as possible.
- Proceed to work site using extreme caution on hills or uneven terrain.

STARTING – READ ENGINE MANUFACTURERS OWNERS’ MANUAL BEFORE STARTING.

- Check all fluids before starting.
- Belts must be disengaged before starting.
- Inspect all connections, teeth, tires, etc. (see Daily Checklist).
- Start engine at half speed and allow sufficient time for oil to circulate before proceeding. Press the by-pass switch and turn the key to the right to start the engine. (See Machine Control section for starting the machine, for cold weather starting, and for starting with a remote or radio control transmitter. See engine owner’s manual for more information.)
- Test controls for proper operation.
- Avoid transverse slopes. Ascend/descend hills straight up and down. A hydraulic safety valve prevents the machine from picking up speed downhill. This may also be used as a brake by decreasing engine speed.
- Hydraulic motor **will not** hold machine as a parking brake. Machine will creep.
- **DO NOT OPERATE THE ENGINE AT AN ANGLE GREATER THAN 25° OR SEVERE ENGINE DAMAGE WILL OCCUR.** PROPER ENGINE OIL LEVEL MUST BE MAINTAINED TO ACHIEVE MAXIMUM ANGLE OF OPERATION OF 25°. (See Engine Owner’s Manual for proper oil level.)
- **DO NOT OPERATE AROUND WATER, GAS, POWER, OR PHONE LINES. IF IN DOUBT, CHECK BEFORE GRINDING.**
- **WEAR FACE SHIELD AND HEARING PROTECTION.**
- **KEEP CLEAR OF CUTTER WHEEL AND MOVING MACHINE PARTS.**
- **KEEP SPECTATORS AWAY.**

- Position machine at stump with cutter wheel a slight distance away from stump. **Do not engage cutter wheel when positioning machine near stump.**



- If you have the optional tongue extension and two-wheel drive, remove the clip and position ground stake as far into the earth as possible. Drive in with hammer if necessary.



- Reduce engine RPM to idle.
- Raise cutter head clear of stump.
- Engage cutter wheel belts by raising engine slide lock and then slowly pushing engagement lever toward front of machine. When the cutter wheel is fully engaged the engine slide lock will be in a raised position.
- Increase engine RPM to full.
- Test controls for proper operation, speed, and unobstructed movement.

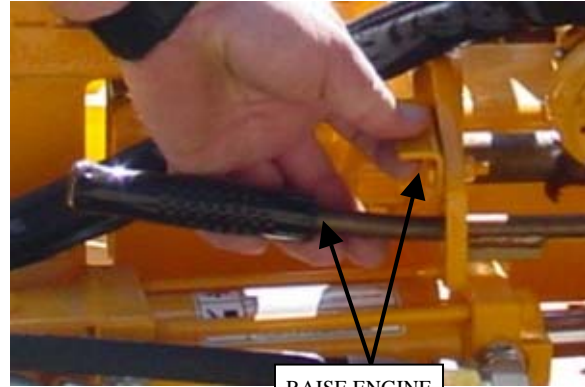

RAISE ENGINE
SLIDE LOCK



CUTTER WHEEL
ENGAGEMENT HANDLE

- Cutter head swing speed should be adjusted to a rate that will allow cutter wheel to pass through stump smoothly. If jerking, bouncing, or significant drops in engine speed occur, swing rate is too rapid and must be decreased.
- Swing speed should be determined and adjusted with the controls in the full open position.
- A counter-rotating valve is located within the hydraulic system to adjust this speed. Turning the handle counter-clockwise will open the bypass and slow swing action. Turning it clockwise will close the valve and increase swing rate.

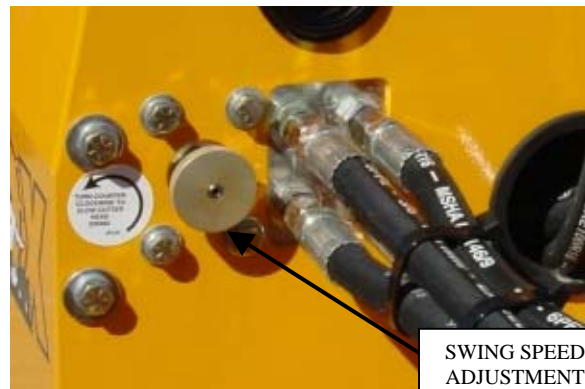

SWING SPEED
ADJUSTMENT

- Lower spinning cutter wheel to stump and make a few light passes at stump to get a feel for the cutting action.



- Gradually increase cutting action and work away at stump by swinging cutter wheel left-to-right-to-left through stump in a sideways motion. Smooth, effortless cutting lengthens machine life, minimizes downtime, and is more profitable in the long run.
- Continue cutting stump by adjusting cutter wheel progressively lower until stump is cut well below ground level.
- Raise cutter wheel and swing clear of stump then reposition grinder closer to the stump, or extend tongue to position machine closer to stump if equipped, for next series of passes. Lower cutter wheel and continue cutting.
- Continue in this manner until stump has been removed.
- Larger stumps may require moving the machine to work at better advantages.
- Raise cutter wheel clear of stump and return to center position.
- Reduce engine speed to idle. **DO NOT TURN MOTOR OFF.** Engine must be allowed to cool slowly at idle for 3 – 5 minutes to avoid damage.
- With engine speed at idle; disengage drive belts by slowly pushing the engagement lever back toward the cutter wheel. The engine slide will lock automatically when belt is disengaged.
- **DO NOT DISENGAGE DRIVE BELTS AT A HIGH ENGINE SPEED.** Damage to belts and machine will occur.
- Allow cutter wheel to come to a full stop before inspecting work area.
- Retract tongue extension; take machine out of freewheel control and pull the tongue stake out of the ground.
- See engine owner's manual for proper shut down procedures and turn motor off.



SAFETY

- **NEVER SERVICE A MACHINE WITH THE ENGINE RUNNING, SEVERE PERSONAL INJURY COULD OCCUR. TURN ENGINE OFF THEN REMOVE IGNITION KEY AND DISCONNECT POSITIVE BATTERY CABLE TO AVOID STARTING MACHINE ACCIDENTALLY.**
- **CUTTER WHEEL MUST BE DISENGAGED BEFORE TURNING ENGINE ON/OFF AND BEFORE SERVICING A MACHINE. OTHERWISE SEVERE PERSONAL INJURY COULD OCCUR AS WELL AS MACHINE DAMAGE.**
- **ALL MACHINE PARTS MUST COME TO A COMPLETE STOP AND HAVE TIME TO COOL COMPLETELY BEFORE SERVICING A MACHINE OR SEVERE INJURY COULD OCCUR, POSSIBLY SERIOUS BURNS AND/OR DISMEMBERMENT.**
- **DO NOT OPERATE A MACHINE WITHOUT A COMPLETE NUMBER OF TEETH IN THE CUTTER WHEEL PROPERLY INSTALLED. EXCESSIVE MACHINE VIBRATION WILL OCCUR CAUSING PREMATURE BEARING FAILURE AND EQUIPMENT DAMAGE.**
- **PLACE THE CUTTER WHEEL ON THE GROUND WHEN PERFORMING SERVICE ON A MACHINE.**

- Check engine oil at dipstick **daily**; take reading with engine **sitting level** (see photos). Add recommended oil and change oil as required. (See engine owners' manual.) Lombardini recommends changing oil and oil filter every 300 hours in a clean environment. However, in the dusty environment of a stump cutter, we recommend changing the oil and oil filter every 50 hours of operation.



INCORRECT POSITION



CORRECT POSITION

SP4012 Kubota Diesel Engine Filters

- 0200134 Oil Filter
- 0200134A Fuel Filter
- 0200102C Air - Main Filter
- 0200102D Air - Safety Filter

- Check hydraulic oil level daily. This Carlton stump grinder is equipped with a gauge that shows the level of oil and the temperature of the oil. When filling the tank with oil, the window of the gauge will also fill with oil, as the level gets higher in the tank. Never fill the oil tank above the **BLACK** line at the top of the gauge. Do not run the machine with the oil level below the **RED** line at the bottom of the gauge.
- The machine is equipped with Citgo AW32 hydraulic oil at the time of manufacture. Use the same or equivalent.
- For a new machine, change the hydraulic oil filter when the stump grinder has been operating for 10 hours. Replace with the same type of in-tank filter element supplied originally, available through Carlton or Carlton dealers. From this point on, change the filter every 200 hours of operation.
- Change hydraulic oil every 500 hours of operation or at least once a year depending on use. Flush the hydraulic tank when changing the hydraulic oil. Replace oil if it has a burnt odor or if it is contaminated. Replace oil if the stump grinder has been stored for a long period of time (all winter).
- Drain the hydraulic tank using the drain plug located on the bottom of the tank. Dispose of used oil according to state regulations.
- Check setscrews in Jackshaft Bearings and Cutter Wheel Bearings for tightness **weekly**. Remove the jackshaft bearing cover to access the jackshaft bearing collar setscrew.



- Clean out Poly Chain® Guard by removing bottom portion of guard weekly. Chip build up will wear Poly Chain® Belt.
- Check cutter wheel, pockets, and teeth for wear. If any repair is needed, see “Servicing Cutter Wheel” section for further instruction.



Always clean tip of grease gun fitting and grease fitting on machine before attaching hose to prevent dirt from being forced into machine parts.

- Grease jackshaft bearings **Daily**. These bearings should be purged using grease **EVERYDAY**. Purge till new grease comes out. Use Texaco Starplex II grease. The jackshaft bearing grease fittings can be accessed easily through the jackshaft bearing cover.
- Grease cutter wheel bearings **Daily**. These bearings should be purged using grease **EVERYDAY**. Purge till new grease comes out. Use Texaco Starplex II grease.

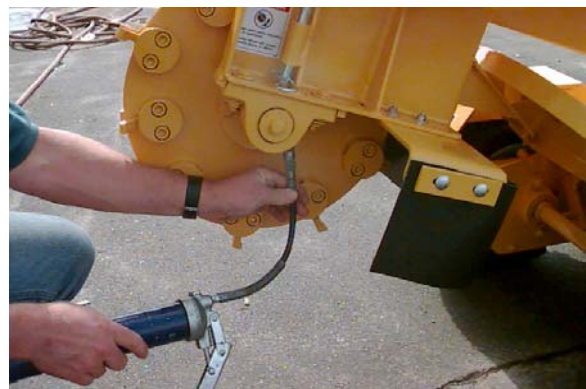

- Grease the bearing supported stub shaft every 1000 hours of operation using Texaco® Starplex II grease. The grease fitting is easily accessible behind the V-belt guard. Apply grease using a hand held grease gun until the pin extends from the pressure relief valve (located 180° from grease fitting on the bearing). Wipe off excess grease. **Excess grease will attract dirt.**

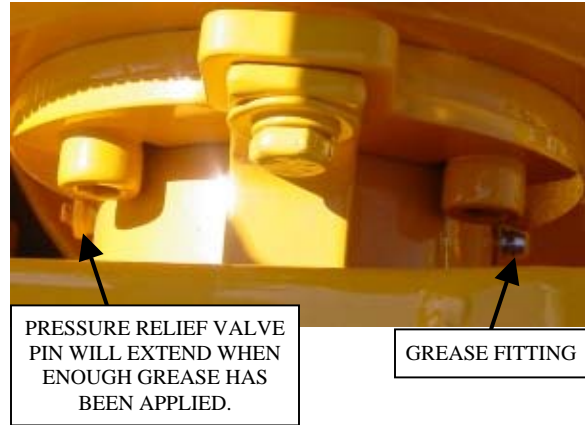

- A grease fitting is on the end of the stub shaft to grease the spline coupling. Apply 2 to 3 shots of grease approximately every 1000 hours of operation. Wipe off excess grease. **Excess grease will attract dirt. DO NOT over grease, over greasing could cause a hydraulic type lift on seals.**



- Grease engine slide assembly every 15 – 20 hours of operation with approximately 2 to 4 shots of Texaco Starplex II grease. (Total of 6 grease fittings.) **DO NOT OVER GREASE.**

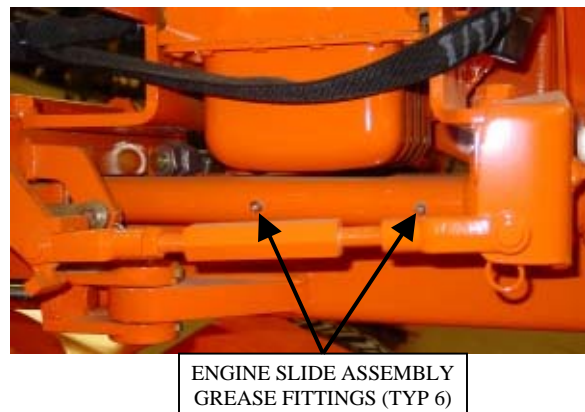

- Grease engagement lever every 15 – 20 hours of operation with approximately 2 to 4 shots of Texaco Starplex II grease.

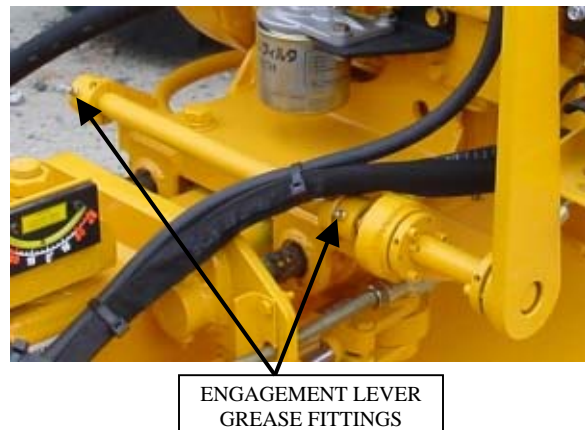

- Grease bottom pivot bearings monthly. Use Texaco Starplex II grease. You cannot over grease this area all parts are heat-treated.



- Grease boom pivot monthly. Use Texaco Starplex II grease. **DO NOT OVER GREASE.**



- Grease steering wheel pivots every 2-3 months. Use Texaco® Starplex II grease. **DO NOT OVER GREASE.**

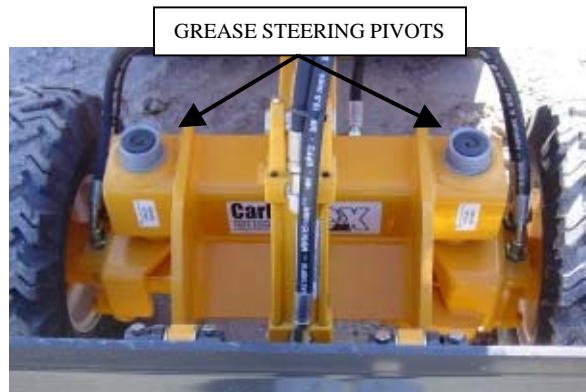

- If supplied with optional tongue extension (two-wheel drive only), extend the tongue and use a cloth covered with grease to lightly coat the tongue extension every 6 months.



- The model SP4012 Kubota Diesel, as well as all of our machines, is built to be a rugged performer. Your new machine is sturdy and our design goals are simplicity and reliability.
- A regularly scheduled maintenance program will pay big dividends in machine life, performance and avoided downtime.

Lubrication Schedule

- Use **Texaco® Starplex II** grease.

CARLTON MODEL SP4012 KUBOTA DIESEL	Daily	15-20 Hrs Monthly	2-3 Mon	6 Mon	Special Comments
- ENGAGEMENT LINKAGE					1-2 shots
- TONGUE (if equipped)					Light coating
- BEARINGS					
- Front Wheel Hubs					Disassemble, clean and repack
- Steering Wheel Pivots					Adjust as required.
- Pivot Head Lift					Three fittings underneath machine
- Pivot Head Swing					Adjust as required.
- Cutter Wheel					Purge bearings daily.
- Jack Shaft					Purge bearings daily.
ENGINE REFER TO ENGINE MANUFACTURERS MANUAL FOR PROPER ENGINE SERVICING					

SP4012KD-8

COMPLAINT	CAUSE	CORRECTION
Engine will not start. (See Engine Manufacturer Manual for further information.)	<ul style="list-style-type: none"> • Loose ground wire. • Loose hot wire. • Dead battery. 	<ul style="list-style-type: none"> • Clean and tighten. • Clean and tighten. • Recharge or replace.
Hydraulic system loss of power.	<ul style="list-style-type: none"> • Low oil. • Valve set too low. • Missing or sheared key on pump shaft. • Bad cylinder. 	<ul style="list-style-type: none"> • Refill with correct oil. • Adjust relief valve. • Remove pump, replace or repair keyway. • Replace cylinder packing.
Swing cylinder loss of power.	<ul style="list-style-type: none"> • Cutter head speed adjustment screw turned wide open. 	<ul style="list-style-type: none"> • To slow cutter head swing at high RPM turn valve counter-clockwise. • Re-adjust for “no bounce” cutting.
Belt Squeal.	<ul style="list-style-type: none"> • Belt tension too loose. • Belt out of line. 	<ul style="list-style-type: none"> • Tighten. • Align Pulleys.
Belt jumping off.	<ul style="list-style-type: none"> • Engaging or disengaging belt at high engine RPM. • Belt keeper too far from belt. 	<ul style="list-style-type: none"> • Only engage or disengage belts at low engine speeds. • Adjust keeper closer to belt.
Cutter wheel vibration.	<ul style="list-style-type: none"> • Tooth missing. • Pocket out of balance. • Improper tooth arrangement. 	<ul style="list-style-type: none"> • Replace missing teeth. • Always replace pockets in pairs across from each other. • Install correctly with like pairs of teeth directly across from each other.
Cutter wheel throwing teeth.	<ul style="list-style-type: none"> • Bad pocket. • Dirt in pocket • Worn cutter wheel 	<ul style="list-style-type: none"> • Replace pocket. • Clean pocket and replace missing teeth. • Replace cutter wheel
Cutter wheel breaking teeth.	<ul style="list-style-type: none"> • Teeth set too far out of pocket. 	<ul style="list-style-type: none"> • Use gauge to set teeth correctly.

COMPLAINT	CAUSE	CORRECTION
Cutter wheel stops turning.	<ul style="list-style-type: none"> • Belt not engaged. • Engine belt broke. • Poly chain® belt broke. • Sheared key in shaft. • Broke cutter wheel shaft. 	<ul style="list-style-type: none"> • Adjust yoke assembly. • Replace belt. • Replace belt. • Replace key. • Replace shaft.
Roar in machine when cutter wheel is engaged.	<ul style="list-style-type: none"> • Belt guards rubbing on jackshaft or cutter wheel shaft. • Jackshaft or cutter wheel bearings going bad. 	<ul style="list-style-type: none"> • Re-position guards off of shafts. • Replace bearings.
Traction loss of power.	<ul style="list-style-type: none"> • Open free wheel valve. • Worn free wheel valve. • Relief valve set too low. • Hydraulic motor worn. 	<ul style="list-style-type: none"> • Close free wheel valve. • Replace free wheel valve. • Increase relief valve pressure by turning relief valve screw inward. • Replace Hydraulic motor.
Bearing will not take grease.	<ul style="list-style-type: none"> • Grease fitting clogged. 	<ul style="list-style-type: none"> • Replace fitting
Cutter head swings faster one way than the other.	<ul style="list-style-type: none"> • Counter balance valve is out of adjustment. 	<ul style="list-style-type: none"> • Adjust counter balance valve to equalize swing speed.

For all Radio Transmitter or Receiver problems, see the Radio Control Manual included at the back of this manual.

Replacing V-Belt

SAFETY

- **NEVER SERVICE A MACHINE WITH THE ENGINE RUNNING, SEVERE PERSONAL INJURY COULD OCCUR. TURN ENGINE OFF THEN REMOVE IGNITION KEY AND DISCONNECT POSITIVE BATTERY CABLE TO AVOID STARTING MACHINE ACCIDENTALLY.**
- **CUTTER WHEEL MUST BE DISENGAGED BEFORE TURNING ENGINE ON/OFF AND BEFORE SERVICING A MACHINE. OTHERWISE SEVERE PERSONAL INJURY COULD OCCUR AS WELL AS MACHINE DAMAGE.**
- **ALL MACHINE PARTS MUST COME TO A COMPLETE STOP AND HAVE TIME TO COOL COMPLETELY BEFORE SERVICING A MACHINE OR SEVERE INJURY COULD OCCUR, POSSIBLY SERIOUS BURNS AND/OR DISMEMBERMENT. DO NOT OPERATE A MACHINE WITHOUT A COMPLETE NUMBER OF TEETH IN THE CUTTER WHEEL PROPERLY INSTALLED. EXCESSIVE MACHINE VIBRATION WILL OCCUR CAUSING PREMATURE BEARING FAILURE AND EQUIPMENT DAMAGE.**
- **PLACE THE CUTTER WHEEL ON THE GROUND WHEN PERFORMING SERVICE ON A MACHINE.**

- Remove V-belt guard cover, which is held on with ten bolts.



- Belt should be disengaged. If it isn't, push the engagement lever back toward the cutter wheel as far as it will go. Engine slide will lock automatically when the belt is disengaged. Belt will be loose when disengaged.



- Loosen, don't remove, the belt keepers around the engine pulley to make removal easier. Remove and replace the engine belt.
- After replacing belt, check engine and jackshaft pulley alignment using a straight edge.
- Engage belt using the engagement lever. Raise the engine slide lock and push the engagement lever toward the front of the machine as far as it will go. Check belt tension. **When the V-belt is tensioned properly, it will deflect 3/8" with 25 lbs. of force applied to the center of the belt between the pulleys.** New belts will stretch and become loose as machine runs. Check belt tension often when belts are new.
- Disengage the belt. **DO NOT START ENGINE.** If belt tension needs to be adjusted, there is a clevis attached to the engagement handle that will tighten or loosen the belt tension. To tighten the belt tension, loosen the jam nut and adjust clevis with a wrench turning down away from the machine. This will make the engine slide further and will tighten the belt. Make only slight adjustments at a time and recheck tension; repeat as necessary until tension is correct. When proper tension is achieved, tighten jam nut.
- Use the same procedure to tighten a loose belt.
- **DO NOT OVER TIGHTEN BELT; OVERLY TIGHT BELTS WILL CAUSE BEARING AND ENGINE DAMAGE.** Turn the clevis in the opposite direction to loosen belt tension.
- Replace belts when worn or when repeated adjustments are necessary. Belts should never get so loose that all of the adjustment capability is used.

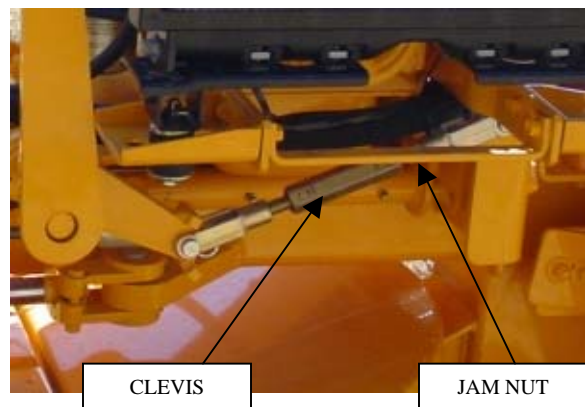
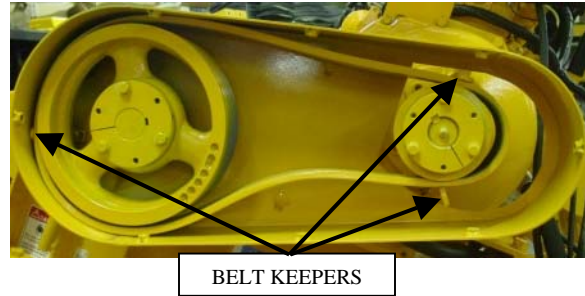

- Retighten the belt keepers when the belt tension has been adjusted.

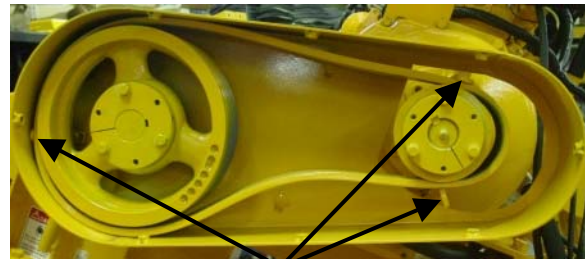

BELT KEEPERS

- If the belt tension was adjusted, the engine slide lock will also have to be adjusted. This locks the engine in the disengaged position so that the cutter wheel will not accidentally engage. When adjusting the engine slide lock, turn the clevis clockwise to shorten the length of the engine slide lock when the engagement linkage was lengthened. The engagement linkage would be lengthened to put more tension on the belt. Lengthen the engine slide lock if the engagement linkage was shortened.

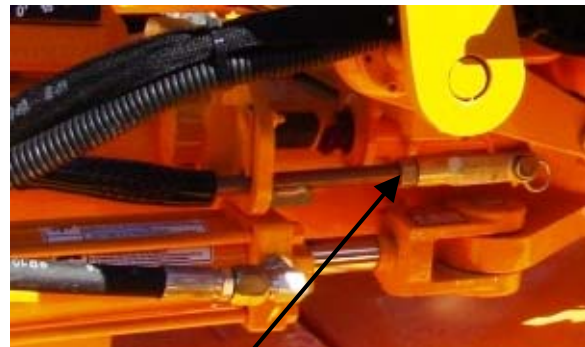

LOOSEN JAM NUT, REMOVE COTTER PIN AND ADJUST CLEVIS TO SHORTEN OR LENGTHEN THE ENGINE SLIDE STOP

- Replace V-belt guard cover and tighten bolts. **DO NOT RUN MACHINE WITHOUT ALL GUARDS IN PLACE AND SECURED.**



GENERAL TENSIONING OF V-BELT DRIVES

Tensioning of belts on the V-belt drive is critical to tighten the outboard bearing and pulley. A few simple rules about tensioning will satisfy most of your requirements:

1. The best tension for the V-belt drive is the lowest tension at which the belts will not slip under the highest load condition.
2. Check the tension on a new drive frequently during the first day of operation.
3. Thereafter, check the drive belt tension periodically.
4. Too much tension shortens belt and bearing life.
5. Keep belts and sheaves free from any foreign material that may cause slippage.

Replacing Poly Chain® Belt

SAFETY

- **NEVER SERVICE A MACHINE WITH THE ENGINE RUNNING, SEVERE PERSONAL INJURY COULD OCCUR. TURN ENGINE OFF THEN REMOVE IGNITION KEY AND DISCONNECT POSITIVE BATTERY CABLE TO AVOID STARTING MACHINE ACCIDENTALLY.**
- **CUTTER WHEEL MUST BE DISENGAGED BEFORE TURNING ENGINE ON/OFF AND BEFORE SERVICING A MACHINE. OTHERWISE SEVERE PERSONAL INJURY COULD OCCUR AS WELL AS MACHINE DAMAGE.**
- **ALL MACHINE PARTS MUST COME TO A COMPLETE STOP AND HAVE TIME TO COOL COMPLETELY BEFORE SERVICING A MACHINE OR SEVERE INJURY COULD OCCUR, POSSIBLY SERIOUS BURNS AND/OR DISMEMBERMENT.**
- **PLACE THE CUTTER WHEEL ON THE GROUND WHEN PERFORMING SERVICE ON A MACHINE.**

Special care needs to be taken with your Poly Chain® belt. Alignment, tension, and cleanliness of this belt are very important. The Poly Chain® belt needs to be checked for tension approximately every 70 to 100 hours of use. The Poly Chain® belt must be running true. If you adjust one bearing more than the other, the belt will run on an angle and will cause belt failure. A belt broken straight across is the result of a shock load. In a shock load failure, the fibers are broken and over a period of time the belt will break down from the shock load and snap in half. A broken belt with lost teeth indicates that the belt was loose. After you have installed or re-tensioned the Poly Chain® belt, you will have to re-adjust the engine V-belts for proper tension.

- Remove the Poly Chain® guard cover and guard bottom cover.



- Remove jackshaft bearing cover to access the jackshaft bearings.



- Loosen Poly Chain® belt by moving jackshaft bearings. **MARK THE BEARINGS SO THAT YOU KNOW HOW THEY ARE POSITIONED ON THE JACKSHAFT PLATE.** Loosen bolts on bearing closest to Poly Chain® guard and remove bolts on the bearing closest to engine belt guard so that side of the jackshaft may be raised to remove Poly Chain® belt.

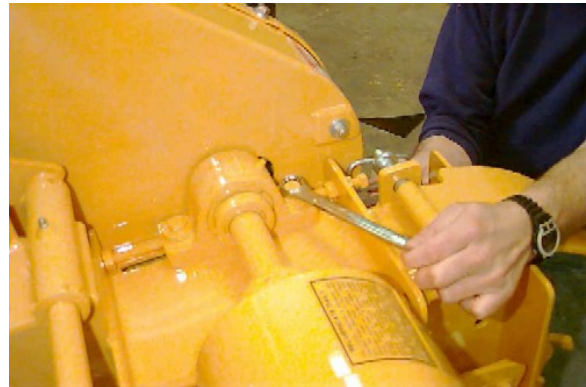

- Loosen the jam bolts in the back and move the bearings back.



- Belt should be disengaged. If it isn't push the engagement lever back toward the cutter wheel as far as it will go. Engine slide will lock automatically when the belt is disengaged.



- Remove old belt and replace with new one. **Do not pry new belt over sprockets since this can break the fibers in the Poly Chain® belt.**
- Check alignment of Poly Chain® sprockets using a straight edge.
- To adjust tension of the belt, slide the bearings back into the place that you had marked. Tighten the jam bolts. To tighten the belts more if needed, loosen the front jam bolts and tighten each of the back jam bolts the same number of revolutions, to keep the alignment true. After the belt is adjusted, tighten the front jam bolts back against the bearing. **After the Poly Chain® belt has been adjusted; check the V-belt tension and alignment. When the V-belt is tensioned properly, it will deflect 3/8" with 25 lbs. of force applied. DO NOT OVER TIGHTEN BELTS; OVERLY TIGHT BELTS WILL CAUSE BEARING AND ENGINE DAMAGE.**
- Replace Poly Chain® belt guard cover and bottom cover and tighten bolts. **DO NOT RUN MACHINE WITHOUT ALL GUARDS IN PLACE AND SECURED PROPERLY.**

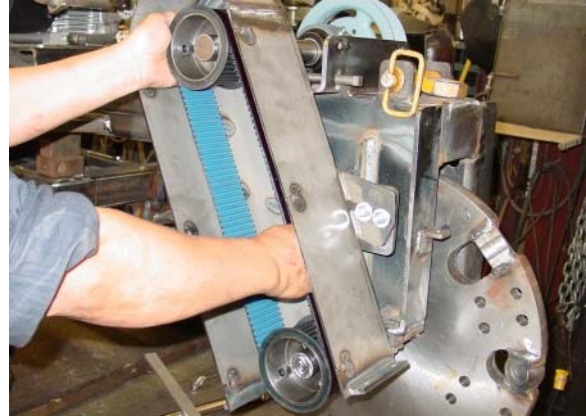

Tensioning Procedure for Gates Poly Chain® GT® Belts

Gates Poly Chain GT belt's high performance characteristics dictate a need for correct installation tension. The following tables provide the required minimum and maximum deflection forces based on the belt pitch, pitch length, width and center distance. Deflection values are simplified based on full rated horsepower capacity per belt width. For drives not covered by the simplified tables, or drives not using full rated horsepower capacity, refer to Page 67 in Gates Poly Chain GT Drives Manual #17595.

Step 1: Based on belt pitch and width, locate the correct table.

Step 2: Locate the RPM of your faster shaft (smaller sprocket) in the first column.

Step 3: Locate the number of grooves on your small sprocket in the second column.

Step 4: Locate the correct column for your belt length (belt lengths shown at the top of each column).

Step 5: Under the correct belt length column, locate the center distance for your drive (center of driver shaft to center of driven shaft in inches).

Step 6: Read down to the intersection for the recommended minimum and maximum deflection force (pounds) for your drive.

Step 7: Apply that deflection force range for the appropriate deflection (1/64" per inch of span length). See sketch.

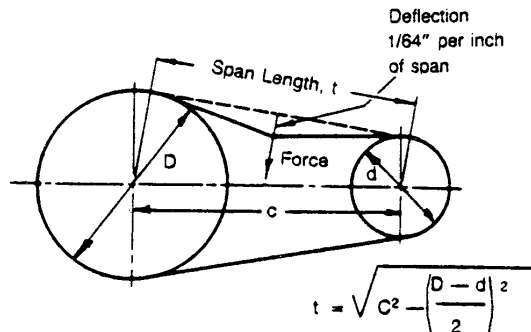

8M-62 Minimum and Maximum Deflection Force (lbs) for 62 mm Wide Poly Chain GT Belts

RPM of Faster Shaft	Number of Grooves on Small Sprocket	Center Distance (inches) for Belt Designation																															
		8M-640, 8M-720				8M-800, 8M-898				8M-1000, 8M-1120				8M-1280, 8M-1440				8M-1792, 8M-2000				8M-2240, 8M-2400				8M-2840, 8M-3200				8M-4000, 8M-4480			
		CD <= 8		CD > 8		CD <= 9		CD > 9		CD <= 13.9		CD > 13.9		CD <= 18.5		CD > 18.5		CD <= 23.5		CD > 23.5		CD <= 35.0		CD > 35.0		CD <= 45.0		CD > 45.0		CD <= 65.5		CD > 65.5	
5000 & Over	22 to 28	21.0	22.5	21.6	22.6	22.8	24.1	23.5	24.9	25.3	27.0	26.3	28.0	27.5	29.6	28.7	30.8	29.7	31.3	31.0	32.9	32.4	34.1	33.0	35.1	34.8	36.1	35.6	38.4	38.0	39.3	37.9	40.3
	30 to 80	22.2	23.6	22.7	23.0	24.2	26.0	24.6	25.9	29.1	27.6	29.2	29.0	31.7	30.1	32.1	31.4	32.8	32.4	34.1	34.0	36.0	34.5	36.3	36.4	37.9	37.2	39.6	39.5	40.5	39.6	41.5	
Under 5000 to 4000	22 to 28	21.6	22.2	23.2	23.3	24.8	24.2	25.6	26.1	27.8	27.1	28.9	28.4	30.6	29.6	31.9	30.8	32.4	32.1	34.0	33.6	35.3	34.1	36.3	36.1	37.4	36.9	39.8	39.5	40.7	39.3	41.8	
	30 to 80	22.5	23.4	23.1	23.4	24.6	26.0	25.1	25.9	27.4	29.5	28.2	29.5	29.7	32.3	30.9	32.6	32.3	34.3	33.3	34.8	35.0	36.8	35.5	37.1	37.5	39.0	38.4	40.7	40.8	42.1	40.9	42.7
Under 4000 to 3200	22 to 28	22.4	23.6	23.0	23.9	24.2	25.6	25.1	26.4	27.1	28.7	28.1	29.9	29.6	31.7	30.8	33.0	32.1	33.6	33.3	35.2	35.0	36.6	35.5	37.7	37.6	38.9	38.5	41.4	41.1	42.3	41.0	43.4
	30 to 80	23.0	24.0	23.7	24.0	25.2	26.3	25.7	26.5	28.2	29.9	29.1	30.1	30.6	33.0	31.9	33.3	33.4	34.9	34.4	35.6	36.1	37.7	36.7	38.1	38.8	39.9	39.8	41.9	42.2	43.3	42.4	44.0
Under 3200 to 2400	22 to 28	23.3	24.9	23.9	25.0	25.2	26.8	26.1	27.6	28.2	30.0	29.3	31.2	30.9	33.3	32.1	34.5	33.5	35.3	34.8	36.9	36.5	38.4	37.1	39.5	39.3	40.8	40.2	43.4	43.0	44.4	42.9	45.6
	30 to 80	23.8	25.0	24.5	25.0	26.0	27.2	26.6	27.8	29.1	30.9	30.1	31.4	31.6	34.0	33.1	34.7	34.5	36.1	35.8	37.1	37.4	39.3	38.1	39.8	40.1	41.7	41.4	43.8	43.6	45.1	44.2	46.1
Under 2400 to 1800	22 to 28	24.4	26.0	25.2	26.1	26.5	28.0	27.5	28.8	29.7	31.4	30.8	32.7	32.5	34.9	33.8	36.1	35.4	37.0	36.6	38.6	38.5	40.3	39.1	41.3	41.4	42.8	42.4	45.5	45.3	46.5	45.3	47.8
	30 to 80	24.9	26.1	25.7	26.1	27.1	28.3	27.9	28.9	30.3	32.3	31.5	32.7	33.0	35.4	34.6	36.3	36.0	37.5	37.3	38.8	39.1	41.1	40.0	41.6	42.0	43.6	43.4	45.8	45.9	47.0	46.4	48.2
Under 1800 to 1400	22 to 28	25.4	27.0	26.1	27.1	27.5	29.1	28.5	29.9	30.8	32.7	32.0	34.0	33.8	36.3	35.1	37.5	36.8	38.5	38.1	40.1	40.0	41.9	40.6	43.0	43.0	44.8	44.1	47.3	47.1	48.4	47.1	49.7
	30 to 80	25.8	27.1	26.6	27.1	28.1	29.4	28.9	30.0	31.4	33.5	32.7	34.0	34.2	36.8	35.9	37.7	37.3	38.9	38.7	40.3	40.5	42.6	41.5	43.2	43.5	45.3	45.1	47.6	47.5	48.9	48.1	50.1
Under 1400 to 900	22 to 28	26.9	28.8	27.7	28.9	29.2	31.2	30.2	31.9	32.7	34.9	33.9	36.2	35.8	38.8	37.2	40.1	39.1	41.2	40.4	42.6	42.5	44.8	43.1	45.9	45.7	47.7	46.8	50.5	49.9	51.8	50.0	53.1
	30 to 80	27.2	28.9	28.2	28.9	29.7	31.4	30.5	32.0	33.2	35.8	34.8	36.3	36.2	39.2	38.0	40.2	39.5	41.6	40.9	43.0	42.9	45.5	43.9	46.1	46.0	48.4	47.7	50.9	50.3	52.2	51.0	53.5
Under 900 to 600	22 to 28	28.5	30.5	29.3	30.6	30.9	33.0	32.0	33.8	34.6	36.9	35.9	38.4	37.9	41.2	39.3	42.4	41.5	43.8	42.7	45.4	45.0	47.5	45.7	48.6	48.4	50.6	49.6	53.5	52.9	54.8	53.0	56.3
	30 to 80	28.8	30.6	29.8	30.7	31.4	33.2	32.3	33.9	35.1	37.9	36.5	38.4	38.2	41.5	40.1	42.5	41.8	44.1	43.3	45.5	45.3	48.2	46.4	48.8	48.7	51.2	50.5	53.9	53.2	55.3	54.0	56.7
Under 600 to 400	22 to 28	30.3	32.3	31.1	32.3	32.9	34.9	34.0	35.7	36.8	39.0	38.1	40.5	40.3	43.5	41.8	44.8	44.2	46.3	45.4	47.9	47.9	50.3	48.5	51.3	51.5	53.5	52.7	56.5	56.2	57.9	56.4	59.5
	30 to 80	30.6	32.3	31.6	32.4	33.4	35.1	34.3	35.7	37.3	40.0	38.8	40.5	40.6	43.9	42.6	44.9	44.5	46.6	46.0	48.0	48.0	50.9	49.3	51.5	51.8	54.1	53.8	56.9	56.6	58.5	57.4	59.9
Under 400 to 200	22 to 28	32.7	35.2	33.6	35.3	35.8	38.1	36.7	38.9	39.8	42.7	41.2	44.1	43.7	47.6	45.2	48.8	47.9	50.6	49.1	52.2	51.8	54.9	52.5	56.0	55.7	58.5	57.0	61.7	60.8	63.2	61.0	64.9
	30 to 80	33.1	35.3	34.2	35.3	36.1	38.3	37.1	39.0	40.3	43.7	41.9	44.2	43.9	47.9	46.0	48.9	48.1	50.9	49.7	52.3	52.1	55.5	53.3	56.2	56.0	59.1	58.0	62.0	61.2	63.9	62.0	65.3

Replacing Jackshaft Bearings

SAFETY

- **NEVER SERVICE A MACHINE WITH THE ENGINE RUNNING, SEVERE PERSONAL INJURY COULD OCCUR. TURN ENGINE OFF THEN REMOVE IGNITION KEY AND DISCONNECT POSITIVE BATTERY CABLE TO AVOID STARTING MACHINE ACCIDENTALLY.**
- **CUTTER WHEEL MUST BE DISENGAGED BEFORE TURNING ENGINE ON/OFF AND BEFORE SERVICING A MACHINE. OTHERWISE SEVERE PERSONAL INJURY COULD OCCUR AS WELL AS MACHINE DAMAGE.**
- **ALL MACHINE PARTS MUST COME TO A COMPLETE STOP AND HAVE TIME TO COOL COMPLETELY BEFORE SERVICING A MACHINE OR SEVERE INJURY COULD OCCUR, POSSIBLY SERIOUS BURNS AND/OR DISMEMBERMENT.**
- **PLACE THE CUTTER WHEEL ON THE GROUND WHEN PERFORMING SERVICE ON A MACHINE.**

In all Carlton® model Stump Grinders, you will find link belt bearings that are made to be purged with grease. It is necessary to purge these bearings everyday till clean grease is seen. **CAUTION should be taken not to allow grease to build up inside the belt guards.**

- Remove the V-belt guard cover.
- Remove V-belts and jackshaft pulley. Remove the bolts from the bushing and use them to screw into the empty threaded holes and tighten slowly to push the bushing out of the belt pulley.



AFTER REMOVING BOLTS, SCREW THE BOLTS BACK INTO THESE HOLES TO PUSH THE BUSHING OUT OF THE PULLEY

- Remove the jackshaft bearing cover to access the jackshaft bearings.



- Remove Poly Chain® belt guard cover.



- Remove Poly Chain® sprocket by removing the bolts inside the sprocket and tapered bushing. Then screw one bolt into third hole to push sprocket off tapered bushing to remove.



- You may cut the jackshaft between the bearings and the Poly Chain® guard.



- Remove old bearings and shaft and replace with new bearings and shaft. Be sure to turn jackshaft with the longest keyway pocket toward the Poly Chain® belt side of the boom and make sure that the locking collars on the bearings are facing inward. Bolt new bearings and jackshaft back into place. Just snug bolts down, do not tighten all the way down, you will need to move them later to adjust belt tension.

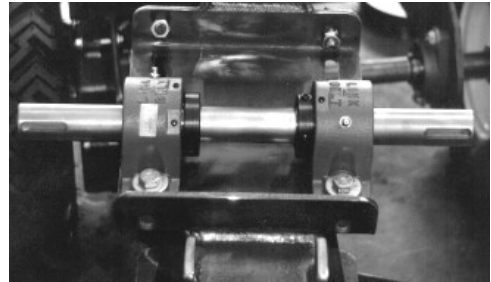

NOTE: To make shaft installation easier, place shaft in a freezer for approximately one hour or overnight if possible. This will shrink the shaft and make installation into the new bearings much easier.

- Place Poly Chain® sprocket and tapered bushing back onto jackshaft and tighten bolts. Replace Poly Chain® belt. **Alignment is very important, use a straight edge from the jackshaft sprocket down to the cutter wheel sprocket to line up sprockets.**



- Using a straight edge, align the engine pulley with the jackshaft pulley and place bushing in and tighten the three bolts down. As you tighten the bushing, make sure that the pulleys stay aligned.



- There are two setscrews in each bearing. Tighten one of them down, remove one, and punch a start point in the shaft to drill a 5/16" diameter hole just deep enough for the screw to enter the shaft. Do this for all four setscrews. This will help prevent shaft from spinning inside of bearing. When replacing setscrews in bearings, use LocTite® 242 to prevent screws from loosening up.

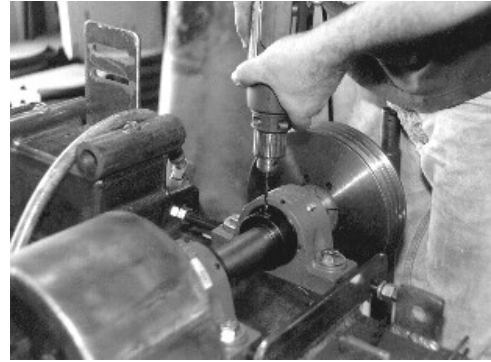

NOTE: Refer to **SERVICING BELTS** section for proper installation and tensioning of all belts.

- Replace V-belt guard cover.



- Replace the jackshaft bearing cover.



- Replace Poly Chain® belt guard cover and end guard cover.



DO NOT RUN MACHINE WITHOUT ALL GUARDS IN PLACE AND SECURED PROPERLY.

Replacing Cutter Wheel Bearings

SAFETY

- **NEVER SERVICE A MACHINE WITH THE ENGINE RUNNING, SEVERE PERSONAL INJURY COULD OCCUR. TURN ENGINE OFF THEN REMOVE IGNITION KEY AND DISCONNECT POSITIVE BATTERY CABLE TO AVOID STARTING MACHINE ACCIDENTALLY.**
- **CUTTER WHEEL MUST BE DISENGAGED BEFORE TURNING ENGINE ON/OFF AND BEFORE SERVICING A MACHINE. OTHERWISE SEVERE PERSONAL INJURY COULD OCCUR AS WELL AS MACHINE DAMAGE.**
- **ALL MACHINE PARTS MUST COME TO A COMPLETE STOP AND HAVE TIME TO COOL COMPLETELY BEFORE SERVICING A MACHINE OR SEVERE INJURY COULD OCCUR, POSSIBLY SERIOUS BURNS AND/OR DISMEMBERMENT.**
- **DO NOT OPERATE A MACHINE WITHOUT A COMPLETE NUMBER OF TEETH IN THE CUTTER WHEEL PROPERLY INSTALLED. EXCESSIVE MACHINE VIBRATION WILL OCCUR CAUSING PREMATURE BEARING FAILURE AND EQUIPMENT DAMAGE.**
- **PLACE THE CUTTER WHEEL ON THE GROUND WHEN PERFORMING SERVICE ON A MACHINE.**

In all Carlton® model Stump Grinders, you will find link belt bearings that are made to be purged. It is necessary to purge these bearing everyday until clean grease is seen. **CAUTION should be taken not to allow grease to build up inside the belt guards.**

- Remove the Poly Chain® guard cover and bottom cover.



- Remove the jackshaft bearing cover to access the jackshaft bearings.



- Loosen Poly Chain® belt by moving jackshaft bearings. **MARK THEM SO THAT YOU KNOW HOW THEY ARE POSITIONED ON THE JACKSHAFT PLATE.** Loosen the four bolts that hold the jackshaft bearings down, do not remove the bolts.



- Loosen jam bolts in the back of the jackshaft bearings and move bearings back to remove the Poly Chain® belt. You may need to unbolt V-belt guard and lift jackshaft end up to remove belt.



- Remove the four bolts on the cutter wheel bearings. Cutter wheel will be free from machine at this point. With the Poly Chain® belt removed, you can start the machine and raise the boom up.

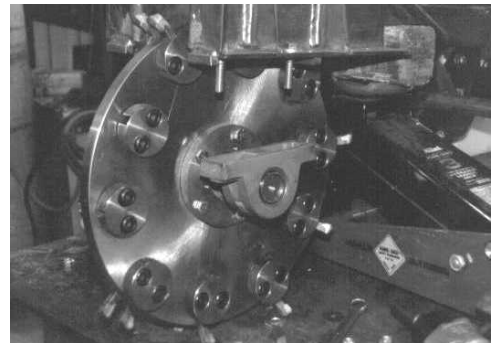

- Cut the cutter wheel shaft on one side of the cutter wheel so that you can get the cutter wheel off of the shaft.



- Remove Poly Chain® sprocket by removing the bolts inside the sprocket and tapered bushing. Then screw one bolt into third hole to push sprocket off tapered bushing to remove.



- Take out the three bolts that hold the bushing to the cutter wheel and place them in the empty threaded holes on the bushing and tighten slowly. This will push the bushing out of the cutter wheel. Remove bushing and cutter wheel.



- Place cutter wheel, bushing and bearings back on new shaft. Place back up under machine and lower boom box on to bearings.

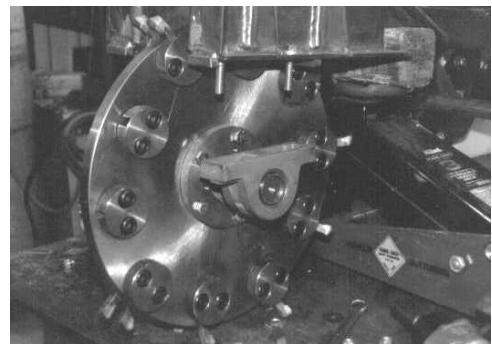

NOTE: To make shaft installation easier, place shaft in a freezer for approximately one hour or overnight if possible. This will shrink the shaft and make installation into the new bearings much easier.

- Bolt bearings and cutter wheel back to boom box and tighten bolts down.



- Place Poly Chain® sprocket and tapered bushing back onto cutter wheel shaft and tighten bolts. Replace Poly Chain® belt. **Alignment is very important, use a straight edge from the jackshaft sprocket down to the cutter wheel sprocket to line up sprockets.**



- There are two setscrews in each bearing. Tighten one of them down, remove one, and punch a start point in the shaft to drill a 5/16" diameter hole just deep enough for the screw to enter the shaft. Do this for all four setscrews. This will help prevent shaft from spinning and walking inside of bearing. When putting setscrew in bearing, use LocTite® 242 to prevent screw from loosening up.

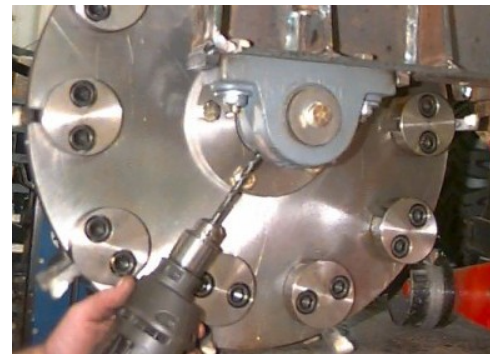

NOTE: Refer to **SERVICING BELTS** section for proper installation and tensioning of all belts.

- Replace the jackshaft bearing cover.



- Replace Poly Chain® guards.



DO NOT RUN MACHINE WITHOUT ALL GUARDS IN PLACE AND SECURED PROPERLY.



SAFETY

- **NEVER SERVICE A MACHINE WITH THE ENGINE RUNNING, SEVERE PERSONAL INJURY COULD OCCUR. TURN ENGINE OFF THEN REMOVE IGNITION KEY AND DISCONNECT POSITIVE BATTERY CABLE TO AVOID STARTING MACHINE ACCIDENTALLY.**
- **CUTTER WHEEL MUST BE DISENGAGED BEFORE TURNING ENGINE ON/OFF AND BEFORE SERVICING A MACHINE. OTHERWISE SEVERE PERSONAL INJURY COULD OCCUR AS WELL AS MACHINE DAMAGE.**
- **ALL MACHINE PARTS MUST COME TO A COMPLETE STOP AND HAVE TIME TO COOL COMPLETELY BEFORE SERVICING A MACHINE OR SEVERE INJURY COULD OCCUR, POSSIBLY SERIOUS BURNS AND/OR DISMEMBERMENT.**
- **DO NOT OPERATE A MACHINE WITHOUT A COMPLETE NUMBER OF TEETH IN THE CUTTER WHEEL PROPERLY INSTALLED. EXCESSIVE MACHINE VIBRATION WILL OCCUR CAUSING PREMATURE BEARING FAILURE AND EQUIPMENT DAMAGE.**
- **PLACE THE CUTTER WHEEL ON THE GROUND WHEN PERFORMING SERVICE ON A MACHINE.**

- Grease steering pivots at least every 2-3 months. Use Texaco® Starplex II grease. **DO NOT OVER GREASE.**

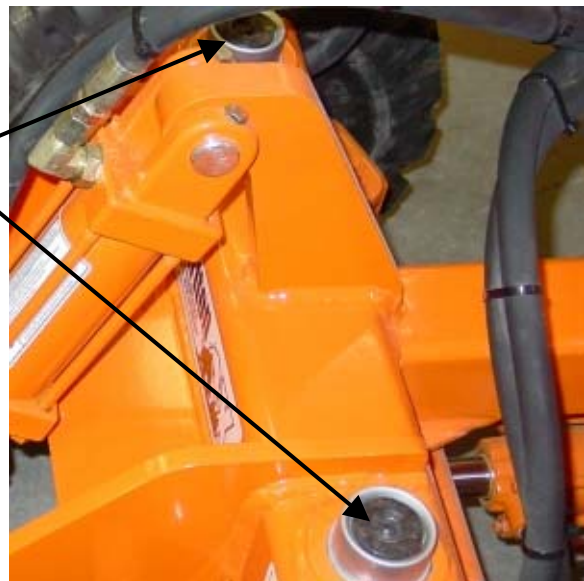

The steering axle is equipped with industrial hubs. To service, jack up the front end, remove cap. Loosen nut and slide wheel off. You are then able to inspect back seals, bearings and races. If necessary you may re-grease and install back on spindle. Tighten axle nut till bearing is tight and wheel will hardly turn. Then back off one notch. Do this at least every 6 months. (See Front Axle Assembly for breakdown)

SAFETY

- **NEVER SERVICE A MACHINE WITH THE ENGINE RUNNING, SEVERE PERSONAL INJURY COULD OCCUR. TURN ENGINE OFF THEN REMOVE IGNITION KEY AND DISCONNECT POSITIVE BATTERY CABLE TO AVOID STARTING MACHINE ACCIDENTALLY.**
- **CUTTER WHEEL MUST BE DISENGAGED BEFORE TURNING ENGINE ON/OFF AND BEFORE SERVICING A MACHINE. OTHERWISE SEVERE PERSONAL INJURY COULD OCCUR AS WELL AS MACHINE DAMAGE.**
- **ALL MACHINE PARTS MUST COME TO A COMPLETE STOP AND HAVE TIME TO COOL COMPLETELY BEFORE SERVICING A MACHINE OR SEVERE INJURY COULD OCCUR, POSSIBLY SERIOUS BURNS AND/OR DISMEMBERMENT.**
- **PLACE THE CUTTER WHEEL ON THE GROUND WHEN PERFORMING SERVICE ON A MACHINE.**

- Swing the cutter wheel to the right to access the boom pivot grease fitting. Grease boom pivot monthly. **Do not over grease.** There is a Pop-Out Valve above the grease fitting, if the pin pops out enough grease has been applied. Wipe off excess grease. **Excess grease will attract dirt.**

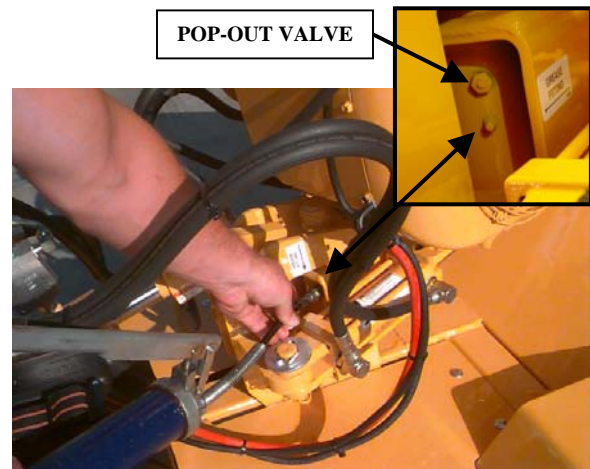

- The boom pivot is equipped with a hardened shaft and Timken® roller bearings. If the boom becomes loose, you will need to apply pressure to the bearings to tighten it. To apply more pressure to the bearings, hold the bottom nut where the cotter pin is. Remove the first nut and tighten the second nut, which will apply pressure to the roller bearings and the boom swing. You can place cutter wheel on ground and put slight pressure on cutter wheel to adjust pivot bearings.



If the main pivot bearings need replacing, you will have to remove the top pin and slide the main pivot out and install the new bearings. **See Upper Pivot Assembly for breakdown.**

- **Boom must be placed in a fixture to hold steady when you remove the pivot pin.**

SAFETY

- **NEVER SERVICE A MACHINE WITH THE ENGINE RUNNING, SEVERE PERSONAL INJURY COULD OCCUR. TURN ENGINE OFF THEN REMOVE IGNITION KEY AND DISCONNECT POSITIVE BATTERY CABLE TO AVOID STARTING MACHINE ACCIDENTALLY.**
- **CUTTER WHEEL MUST BE DISENGAGED BEFORE TURNING ENGINE ON/OFF AND BEFORE SERVICING A MACHINE. OTHERWISE SEVERE PERSONAL INJURY COULD OCCUR AS WELL AS MACHINE DAMAGE.**
- **ALL MACHINE PARTS MUST COME TO A COMPLETE STOP AND HAVE TIME TO COOL COMPLETELY BEFORE SERVICING A MACHINE OR SEVERE INJURY COULD OCCUR, POSSIBLY SERIOUS BURNS AND/OR DISMEMBERMENT.**
- **DO NOT OPERATE A MACHINE WITHOUT A COMPLETE NUMBER OF TEETH IN THE CUTTER WHEEL PROPERLY INSTALLED. EXCESSIVE MACHINE VIBRATION WILL OCCUR CAUSING PREMATURE BEARING FAILURE AND EQUIPMENT DAMAGE.**
- **PLACE THE CUTTER WHEEL ON THE GROUND WHEN PERFORMING SERVICE ON A MACHINE.**

- There are twenty (20) teeth to a complete set on the model SP4012. Two (2) straight teeth, nine (9) left 45° teeth and nine (9) right 45° teeth.



- A locking pin is provided to hold cutter wheel in position during tooth removal and re-installation. Locking pin will only lock on outer teeth.

NEVER PLACE HAND ON CUTTER WHEEL TO HOLD IN PLACE WHILE CHANGING TEETH. BE SURE TO REMOVE PIN BEFORE OPERATING.



- A Tooth Setting Gauge (P/N 0450111) is provided with each machine for proper tooth installation. Line all teeth up with the inside edge of the groove in the gauge. Set **ALL** teeth to this edge with gauge against pocket, not against cutter wheel. **See Cutter Wheel Assembly for breakdown.**



TOOTH ARRANGEMENT

- Inspect pockets, teeth and bolts for damage and replace as required.
- When replacing pockets, always replace new pockets across from each other in order to prevent vibration.
- Replacement teeth must be carbide tipped and have like design as provided with the machine.
- Use anti-seize on threads to prevent bolts from “freezing up” in cutter wheel.
- When replacing complete set of teeth, be sure to duplicate original factory tooth arrangement.
- Torque bolts to 150 ft/lbs.

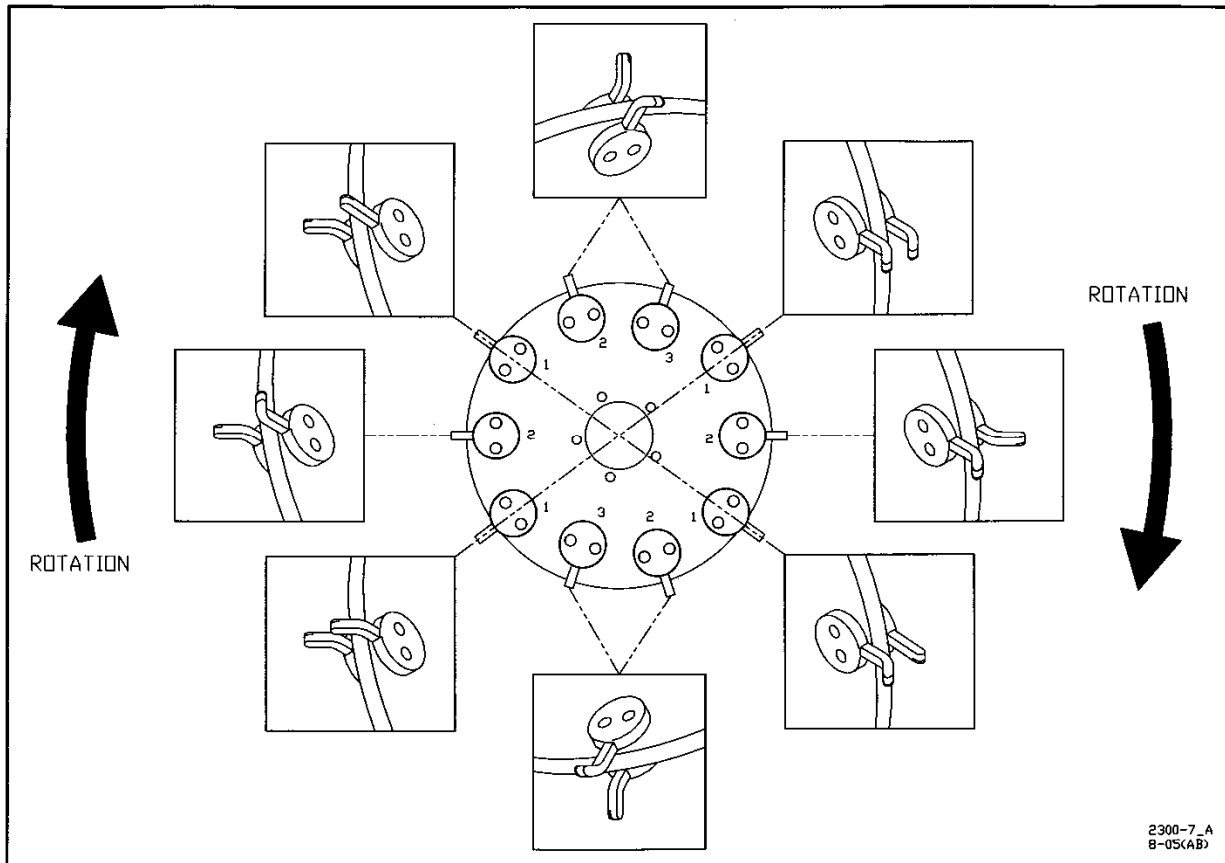

opposing outside pockets carry like arrangements of teeth to cancel vibration

- Straight teeth are mounted in **TWO OPPOSING OUTSIDE POCKETS.** A straight tooth must have a 45° tooth accompanying it in the same pocket set.
- The opposite pocket sets should have this same combination of straight and 45° teeth, except with positions reversed. Mounting these teeth opposite each other on the cutter wheel cancels damaging vibration.
- **Two Remaining Outside Pockets** must have 45° teeth overlapping centerline of wheel to make plunge cuts possible. Mount two left 45° teeth opposite two right 45° teeth.
- Inside pockets require 45° teeth mounted away from the wheel.

OPTIONAL:

Sandvik® Dura Disk II Cutter Wheel

- If the machine is supplied with the optional Dura Disk II cutter wheel, there are thirty-two (36) teeth to a complete set. There are eight (12) Short Plow Bolt Bits (Carlton part #0450131) and twenty-four (24) Plow Bolt Bits (Carlton part #0450130).
- **DO NOT OPERATE A MACHINE WITHOUT A COMPLETE NUMBER OF TEETH IN THE CUTTER WHEEL PROPERLY INSTALLED. EXCESSIVE MACHINE VIBRATION WILL OCCUR CAUSING PREMATURE BEARING FAILURE AND EQUIPMENT DAMAGE.**
- A locking pin is provided to hold cutter wheel in position during tooth removal and re-installation.
- The locking pin will only lock in the deep slots of the outer teeth. Line the slot up with the locking pin slot and insert the pin to lock position. The pin will need to be removed and reinserted as wheel is rotated to change remaining teeth. (Some early machines will only lock on an outside 20° tooth.)
- **NEVER PLACE YOUR HAND ON THE CUTTER WHEEL TO HOLD IT IN PLACE WHILE CHANGING TEETH.**
- **BE SURE TO REMOVE THE PIN BEFORE OPERATING THE STUMP CUTTER.**
- The teeth do not require a setting gauge. The only requirement is to be installed in the proper direction and tightened to the proper torque as discussed in the next section.
- **When replacing a cutter wheel tooth, replace the tooth and nut as a set and use anti-seize on the threads.**



TOOTH ARRANGEMENT

- Inspect pockets, teeth and bolts for damage and replace as required.
- When replacing a cutter wheel tooth, replace the tooth and nut as a set and use anti-seize on the threads.
- When replacing teeth and pockets, also replace the teeth and pockets across from each other diagonally in order to maintain wheel balance and prevent vibration.
- All teeth and pockets are of a specific design and must be replaced with original manufacturer’s replacement parts. Replacement teeth must be carbide tipped.
- When replacing complete set of teeth, be sure to duplicate original factory tooth arrangement. SEE DIAGRAM BELOW.
- The seating surfaces of the tooth and pocket are formed, but make sure the tooth is inserted with the carbide facing the direction of rotation.
- The pictured view is the engraved side of the wheel. The wheel is engraved with outside pocket numbers, outside pocket angle/direction (20 R or 20 L), and wheel rotation. (The engraved side of wheel is marked left side of wheel; this is for manufacturing purposes only. It does not refer to the left side of the machine as described in the General Information section.)
- Outside pocket teeth are Short Plow Bolt Bits. These pockets are angled and welded in place. You can switch teeth from one outside pocket to a pocket that is the opposite direction to prolong tooth life, such as switching a tooth from a 20 R with a tooth from a 20 L pocket. The cutting edge is the corner and this will turn the opposite corner out for use.
- These teeth are tightened with Stover Lock Nuts. Torque on Stover locking nuts is not to exceed 270 ft/lbs.
- All teeth on cutter wheel sides are Plow Bolt Bits. When changing these teeth you must remove both teeth in the same pocket, one on each side of the wheel. When the nuts are torqued, the pocket is jammed and the teeth can only be removed this way.
- These teeth are also tightened with Stover Lock Nuts. Torque on Stover locking nuts is not to exceed 270 ft/lbs.
- The pocket will receive wear when cutting and can be switched from one side of the cutter wheel to the other to prolong life. Remember the teeth must be replaced in the original position on each side of the wheel.

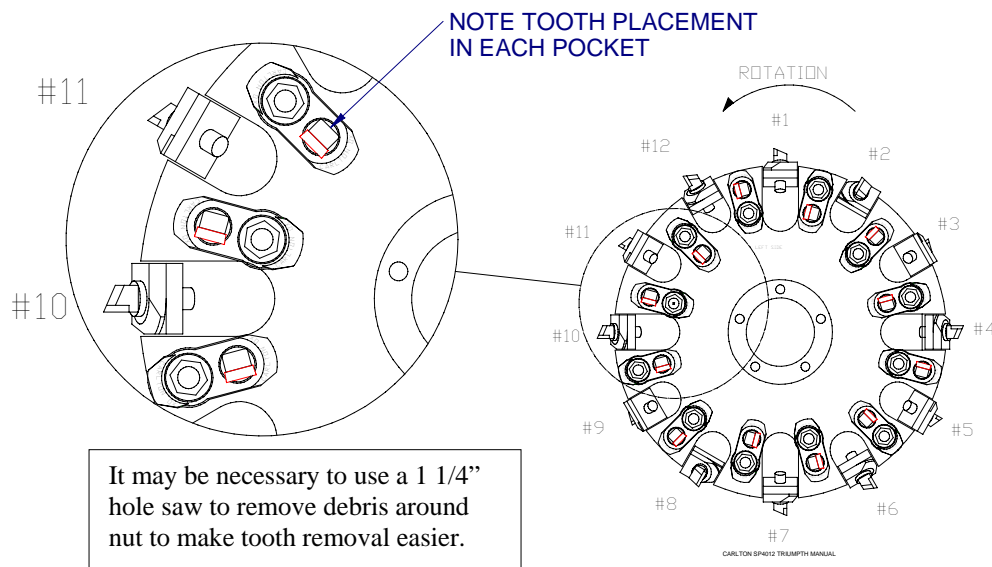

TOOTH SHARPENING

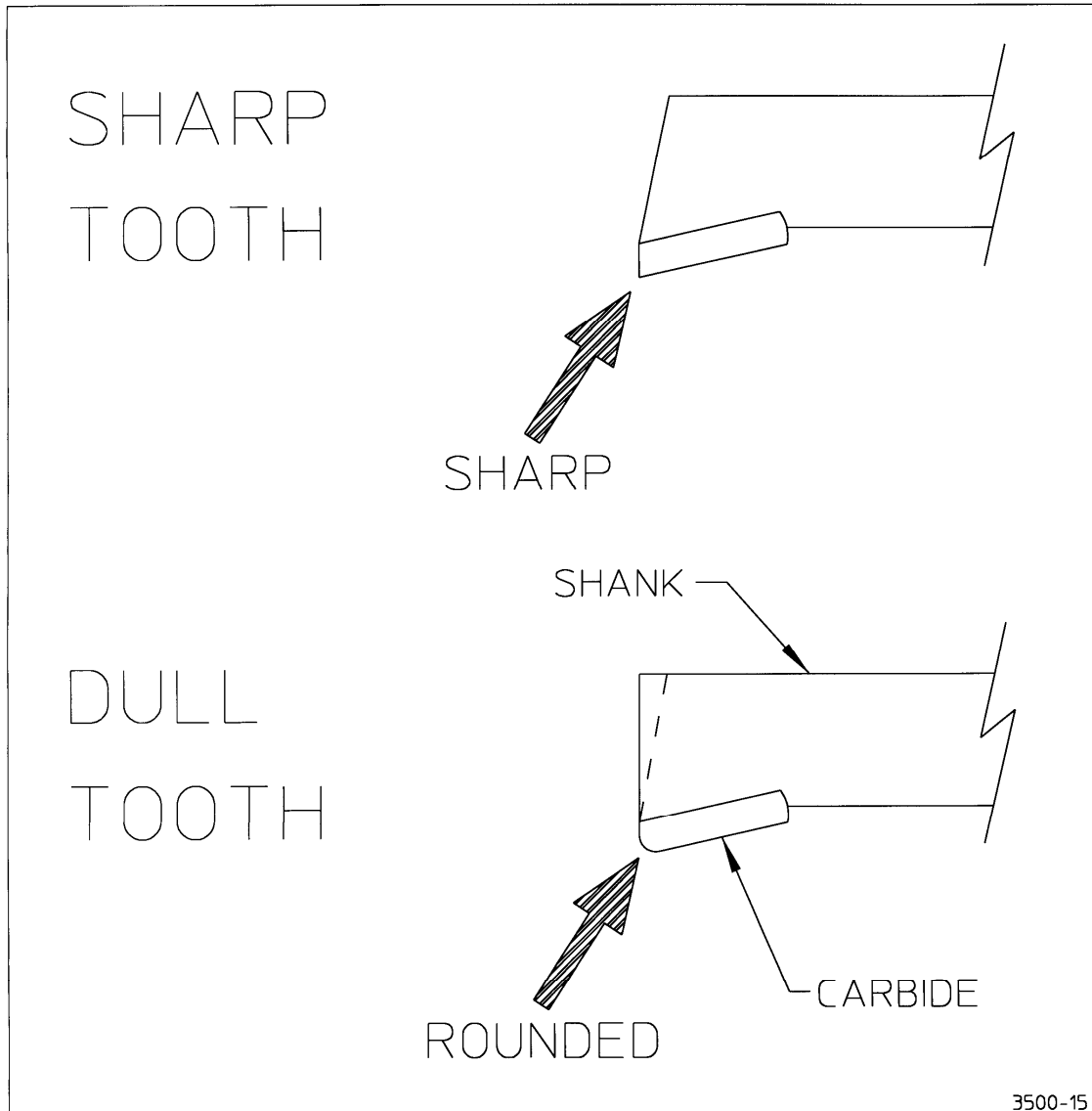

Begin by chamfering shank back past edge of carbide. You do this because if it is not back far enough the shank will hit the stump and not the carbide, thus causing a lot of vibration. Once the shank is angled far enough back, then begin sharpening carbide.

- **Cut shank with a standard rock and cut carbide with a silicone carbide or diamond rock.**
CAUTION: GRINDING CARBIDE CAN BE A HEALTH HAZARD. Use facemask to prevent breathing in harmful material while grinding.

SAFETY

- **NEVER SERVICE A MACHINE WITH THE ENGINE RUNNING, SEVERE PERSONAL INJURY COULD OCCUR. TURN ENGINE OFF THEN REMOVE IGNITION KEY AND DISCONNECT POSITIVE BATTERY CABLE TO AVOID STARTING MACHINE ACCIDENTALLY.**
- **CUTTER WHEEL MUST BE DISENGAGED BEFORE TURNING ENGINE ON/OFF AND BEFORE SERVICING A MACHINE. OTHERWISE SEVERE PERSONAL INJURY COULD OCCUR AS WELL AS MACHINE DAMAGE.**
- **ALL MACHINE PARTS MUST COME TO A COMPLETE STOP AND HAVE TIME TO COOL COMPLETELY BEFORE SERVICING A MACHINE OR SEVERE INJURY COULD OCCUR, POSSIBLY SERIOUS BURNS AND/OR DISMEMBERMENT.**
- **PLACE THE CUTTER WHEEL ON THE GROUND WHEN PERFORMING SERVICE ON A MACHINE.**

- The most service you should have to do for the **bearing supported stub shaft** is to grease it properly. The bearing grease fitting is easily accessible behind the V-belt guard. Another grease fitting is on the end of the stub shaft to grease the splines in the coupling. Follow the instructions in the Machine Maintenance section for frequency and application of grease. Also see the Lubrication Chart.



BEARING SUPPORTED STUB SHAFT GREASE FITTINGS



- If the bearing supported stub shaft should fail for any reason, these are the procedures for replacement. First remove the V-belt following the instructions in the Servicing Belt Section of this manual. Remove the engine belt keepers instead of just loosening the bolts and lay aside to put back on the stub shaft assembly.



REMOVE V-BELT GUARD COVER AND FOLLOW INSTRUCTIONS FOR REMOVING V-BELT.

- Next you will need to remove the jackshaft sheave. Remove the bolts in the jackshaft sheave and screw them back into the empty threaded holes to push the bushing out of the sheave and remove the bushing and sheave. Make sure to keep all machine parts and hardware together to make reassembly easier.



- Remove the bolts holding the belt guard onto the machine and remove the belt guard.

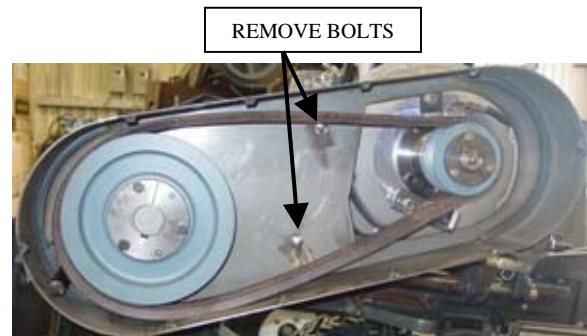

- Then remove the engine sheave. Remove the bolts in the engine sheave bushing and screw them into the extra threaded holes to push the bushing out of the sheave and remove the bushing and sheave.

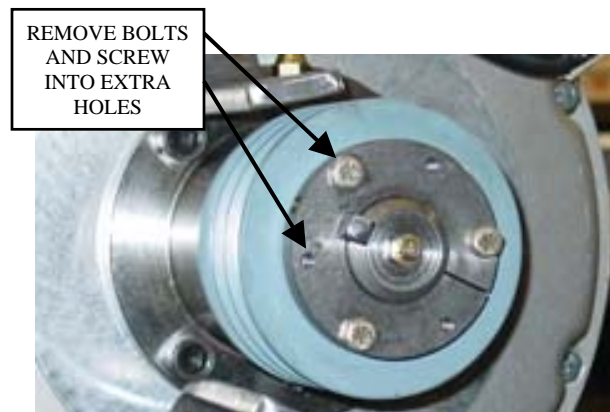

- Now remove the bearing supported stub shaft plate. Remove the bolts holding the shaft plate to the engine. There are two 10MM bolts (at the top) and six 8MM bolts to remove. Pull the plate straight off; the back of the shaft has a splined insert.



- Remove the coupling plate. The bolts are 12MM holding this plate to the flywheel. These bolts had LocTite® blue applied before installation.

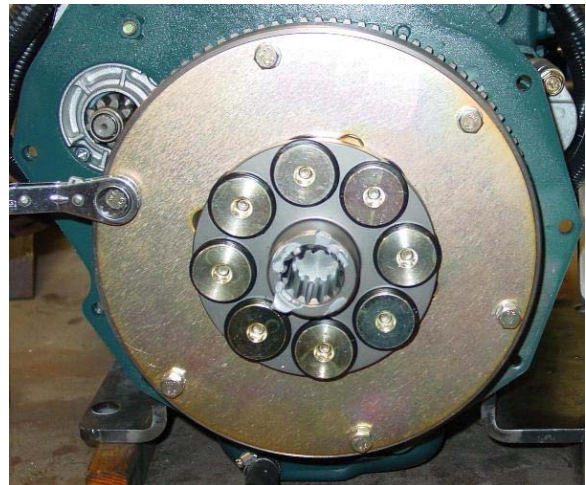

- When parts have been removed, clean the engine flywheel with a cleaning solvent and check for burrs around the holes and on the surface of the flywheel. Use a very fine sand paper to remove any burrs.



- Replace any parts that need replacing. Put stub shaft coupling plate onto the flywheel.
- The coupling plate is attached using 12MM bolts with lock washers. Put LocTite® 242 (blue) on the end of the bolt and lightly tighten all bolts. When all bolts have been inserted and lightly tightened, torque all bolts 10 ft. lbs.

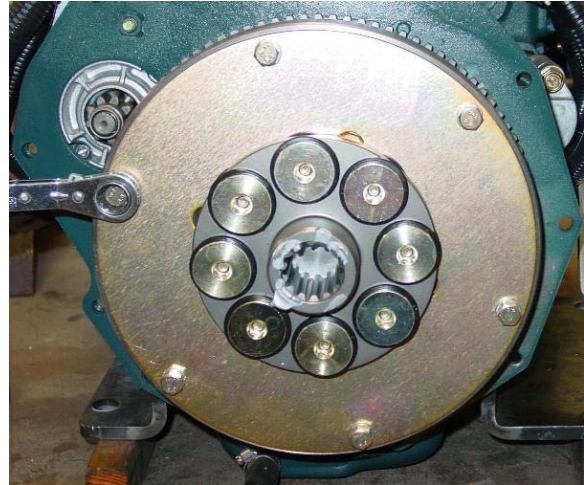

- Put anti-seize (coupling lubricant) on the inside of the coupling. **Lightly** grease internal area of spline using supplied coupling grease (over greasing could cause a hydraulic type lift on seals).



- **Lightly** grease external area of spline using supplied coupling grease (over greasing could cause a hydraulic type lift on seals). Line up external splines with the coupling ID and slide the stub shaft plate into place.



- Replace the stub shaft housing being sure to line up the splines and the two pins on the inside of the housing.



- Replace the 10MM & 8MM bolts with washers and torque. There are eight bolts holding the plate to the engine.
- Torque the 10MM bolts 29-33 ft. lbs. and the 8MM bolts 13-15 ft. lbs.



ROTATE THE STUB SHAFT TO PUT THE GREASE FITTING ON THE RIGHT SIDE

- Remove the stub shaft and rotate it till the grease fitting is on the right side when you are facing the assembly. (Shown here on the left side.)



- Grease the bearing housing fitting until the pin extends from the pressure relief valve (located 180° from the grease fitting). This may have been done at the factory before shipping the unit, check location of pin.



- Start replacing parts in the opposite order in which they were removed. It will be easier to bolt the belt keepers onto the stub shaft plate before you put the V-belt guard on. Replace the V-belt guard and then replace the engine and jackshaft sheaves. Torque the bolts in the jackshaft sheave to 30 ft. lbs and torque the bolts in the engine sheave to 10 ft. lbs. (120 in. lbs.).



- Replace the V-belt and align the sheaves as instructed in the Servicing Belt Section of the manual. Adjust sheaves as necessary to get the proper belt alignment. Check belt tension and set as described in Servicing Belt section. Belt alignment and tension are very important for long bearing life.
- **Never run the machine without all guards in place and secured properly.**



SAFETY

- **NEVER SERVICE A MACHINE WITH THE ENGINE RUNNING, SEVERE PERSONAL INJURY COULD OCCUR. TURN ENGINE OFF THEN REMOVE IGNITION KEY AND DISCONNECT POSITIVE BATTERY CABLE TO AVOID STARTING MACHINE ACCIDENTALLY.**
- **CUTTER WHEEL MUST BE DISENGAGED BEFORE TURNING ENGINE ON/OFF AND BEFORE SERVICING A MACHINE. OTHERWISE SEVERE PERSONAL INJURY COULD OCCUR AS WELL AS MACHINE DAMAGE.**
- **ALL MACHINE PARTS MUST COME TO A COMPLETE STOP AND HAVE TIME TO COOL COMPLETELY BEFORE SERVICING A MACHINE OR SEVERE INJURY COULD OCCUR, POSSIBLY SERIOUS BURNS AND/OR DISMEMBERMENT.**
- **PLACE THE CUTTER WHEEL ON THE GROUND WHEN PERFORMING SERVICE ON A MACHINE.**
- **RELEASE HYDRAULIC PRESSURE BEFORE PERFORMING ANY SERVICE TO HYDRAULIC LINES OR OTHER COMPONENTS.**
- **FLUID UNDER PRESSURE CAN PENETRATE THE SKIN AND CAUSE SEVERE INJURY. SEEK IMMEDIATE MEDICAL ATTENTION IF SKIN IS PENETRATED. CHECK HOSES AND FITTINGS USING A BOARD OR CARDBOARD; DO NOT USE HAND OR FINGER. ALWAYS WEAR EYE PROTECTION.**

HYDRAULIC OIL & FILTER

- Check hydraulic oil level daily. This Carlton stump grinder is equipped with a gauge that shows the level of oil and the temperature of the oil. When filling the tank with oil, the window of the gauge will also fill with oil, as the level gets higher in the tank. Never fill the oil tank above the **BLACK** line at the top of the gauge. Do not run the machine with the oil level below the **RED** line at the bottom of the gauge.
- The machine is equipped with Citgo AW32 hydraulic oil at the time of manufacture. Use the same or equivalent.



- For a new machine, change the hydraulic oil filter when the stump grinder has been operating for 10 hours. Replace with the same type of in-tank filter element supplied originally, available through Carlton or Carlton dealers. From this point on, change the filter every 200 hours of operation.
- Change hydraulic oil every 500 hours of operation or at least once a year depending on use. Flush the hydraulic tank when changing the hydraulic oil. Replace oil if it has a burnt odor or if it is contaminated. Replace oil if the stump grinder has been stored for a long period of time (all winter).
- Drain the hydraulic tank using the drain plug located on the bottom of the tank. Dispose of used oil according to state regulations.



HYDRAULIC OIL COOLER

(only on remote control machines)

- There is a hydraulic oil cooler on all remote control machines to keep the hydraulic oil from over heating. There is a temp sensor in the bottom of the oil cooler and if the oil temperature rises to 140° or higher the fan comes on to cool the oil. The fan may go on and off as the temperature of the oil changes depending on the environment and the operation of the grinder.
- Keep the fins clean. Use a garden hose and a mild detergent. Do not use a power washer as it may cause the fins to bend. Do not use an industrial strength detergent that may cause the metal to deteriorate.
- Inspect all connections and hoses for leaks and wear. Replace if necessary. Use extra care when inspecting hoses with fluid under pressure. DO NOT use your finger or hand to inspect for leaks, use a board or cardboard. Follow all safety procedures at the beginning of the Servicing Hydraulics section.



REPLACING HYDRAULIC PUMP

- Engine must be off and key removed.
- Relieve pressure on hydraulic lines before proceeding.
- Disconnect hydraulic lines from pump and cap.
- Remove the two bolts holding the pump to the engine and remove pump.
- Replace pump lining up rectangular shaft with slot in engine. Tighten bolts.



REMOVE 2 PUMP BOLTS

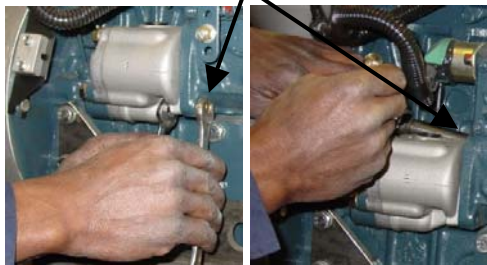

REMOVE THE PUMP



LINE UP THE RECTANGULAR SHAFT WITH THE SLOT IN THE ENGINE

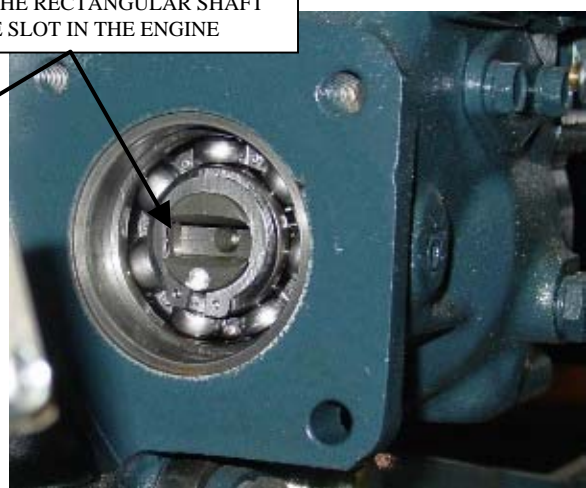
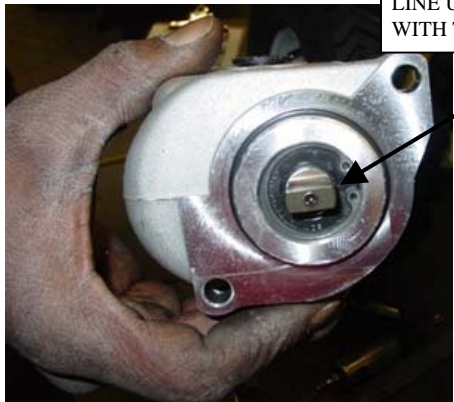

REPLACING HARDENED BUSHINGS

(Two-Wheel Drive Model shown)

- Hardened bushings have been incorporated into the machine to protect the frame from wear and damage.
- Should a bushing need replacing, disconnect the rod end from the frame and swing cylinder out of the way.
- Position the new bushing directly above the old bushing and gently tap new bushing down into position thus removing the old bushing.
- Swing cylinder back into position. Use new pin assemblies to re-install rod end to frame.



REMOTE BOX WIRING DIAGRAM

SP4012 REMOTE CONTROL WIRING DIAGRAM
W/16-PIN CONNECTOR

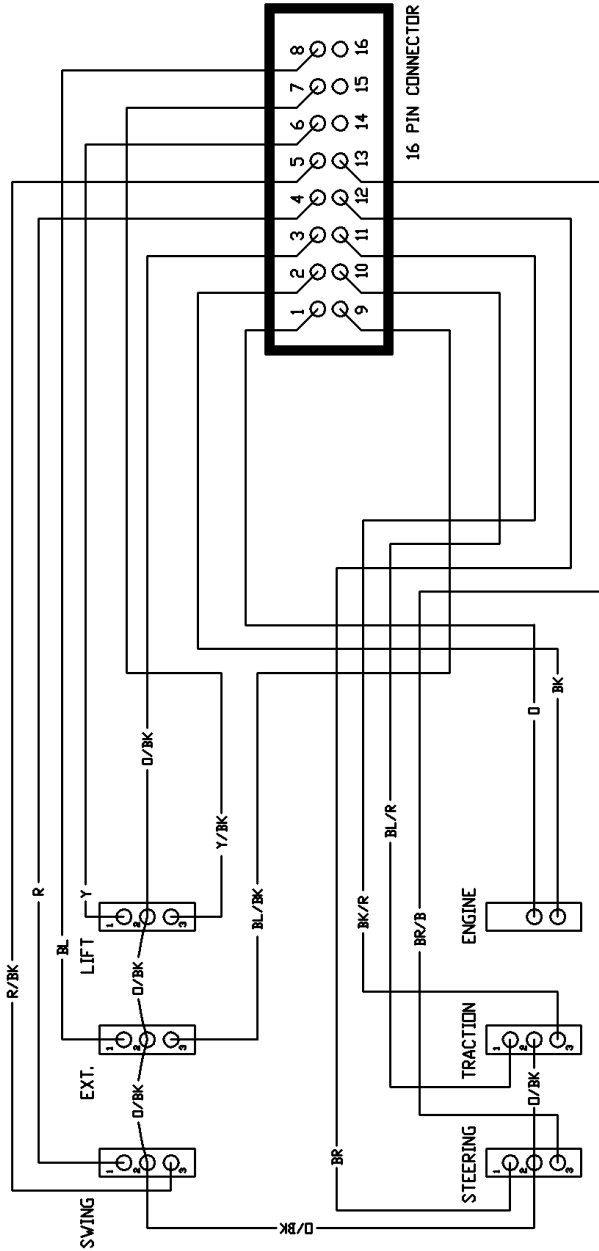

COLOR CODES

R	= RED
Y	= YELLOW
O	= ORANGE
PR	= PURPLE
GY	= GRAY
GR	= GREEN
BL	= BLUE
BK	= BLACK
BR	= BROWN
W	= WHITE
R/BK	= RED/BLACK
O/BK	= ORANGE/BLACK
Y/BK	= YELLOW/BLACK
Y/R	= YELLOW/RED
O/R	= ORANGE/RED
BL/BK	= BLUE/BLACK
BL/R	= BLUE/RED
BR/BK	= BROWN/BLACK
BK/Y	= BLACK/YELLOW
BK/BL	= BLACK/BLUE
BK/R	= BLACK/RED

16-PIN CONNECTOR FUNCTIONS

FUNCTION	COLOR	PIN #
POWER IN	ORANGE	1
POWER OUT	BLACK	2
GROUND	ORANGE/BLACK	3
SWING (R)	RED	4
SWING (L)	RED/BLACK	5
LIFT (UP)	YELLOW	6
LIFT (DOWN)	YELLOW/BLACK	7
EXTENSION (OUT)	BLUE	8
EXTENSION (IN)	BLUE/BLACK	9
TRACTION (FORWARD)	BLACK/RED	10
TRACTION (REVERSED)	BLACK/RED	11
STEERING (RIGHT)	BROWN	12
STEERING (LEFT)	BROWN/BLACK	13

EC # 040402 - WAS 2500-12B (MACHINE WAS RENAMED)
Carlton PROFESSIONAL TREE EQUIPMENT
J.P. CARLTON CO. DIVISION DWP, INC.
CHECKED BY:
SP4012-12 CURRENT (AB/4/2/04)

RADIO WIRING DIAGRAM

SP4012 MACHINE REMOTE WIRING DIAGRAM (KUBOTA)
W/16-PIN CONNECTOR, R-160 CONNECTOR,
DUAL DRIVE MOTORS, & OIL COOLER

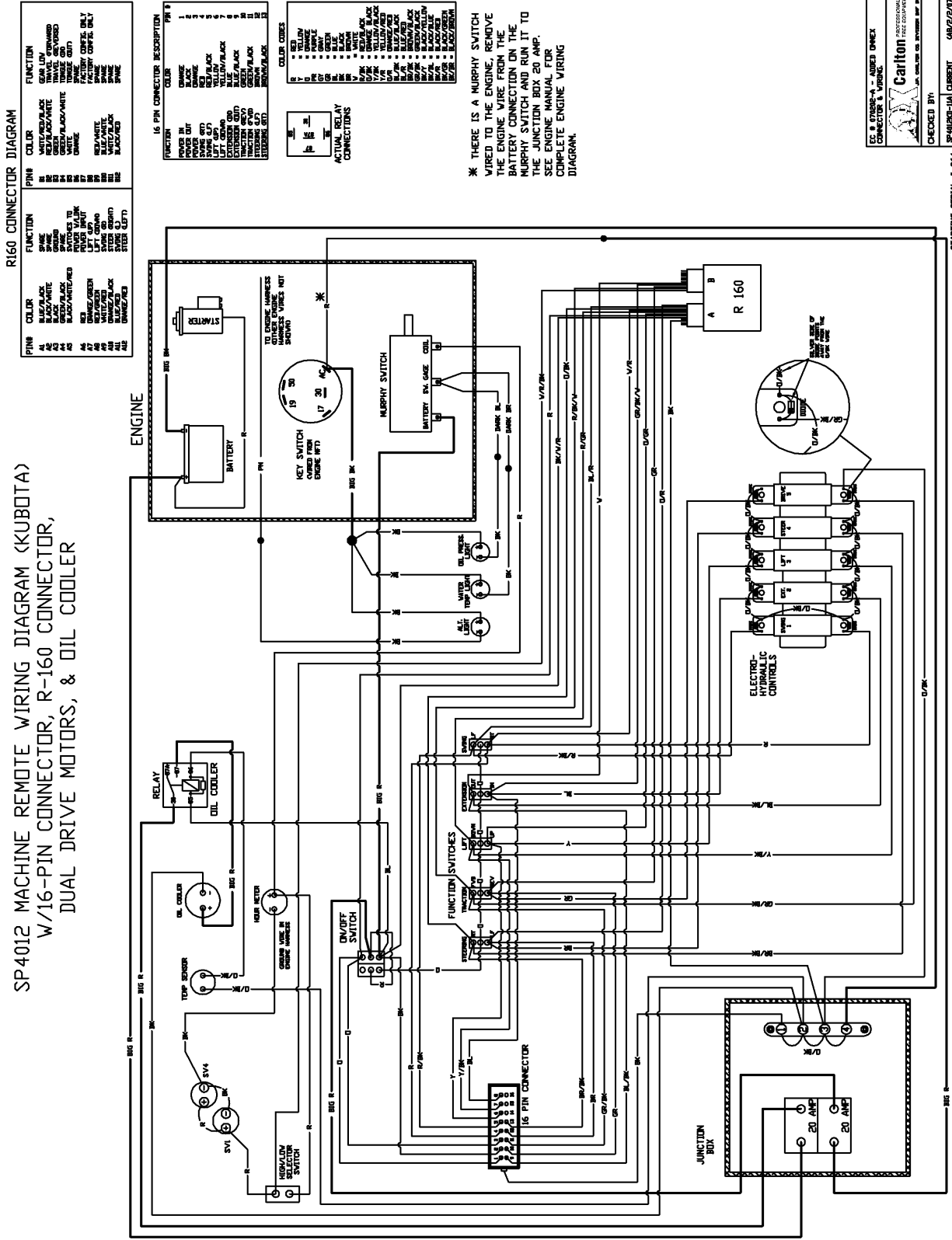

IC & OTHERS - AWED DMEK
CONNECTOR & WIRING
Carlton
PROFESSIONAL
TREE EQUIPMENT
CHECKED BY: [Signature]
SP4012-141 CURRENT 04/2/01/7

STARTING SERIAL # 264

SEE RADIO CONTROL MANUAL, INCLUDED IN THIS MANUAL, FOR MORE INFORMATION.

HYDRAULIC INLET ASSEMBLY

ITEM NO	PART NO	DESCRIPTION	QTY
1	0300199	Work Section	1
2	0300142H	Hyd Pump 4012 – Kubota	1
3	0300354J1	3/4 Hose - 3/4 FJ45T- Dayco	1
4	0300212	3/4 JIC - 5/8 ORB - 6400-12-10	1
5	0300219	1/2 JIC - 1/2 ORB 90 - 6801-8	1
6	0300236	1/2 JIC-1/2 ORB- 6400-8	1
7	H250401	Hose Assembly	1
8	H250402	Hose Assembly	1

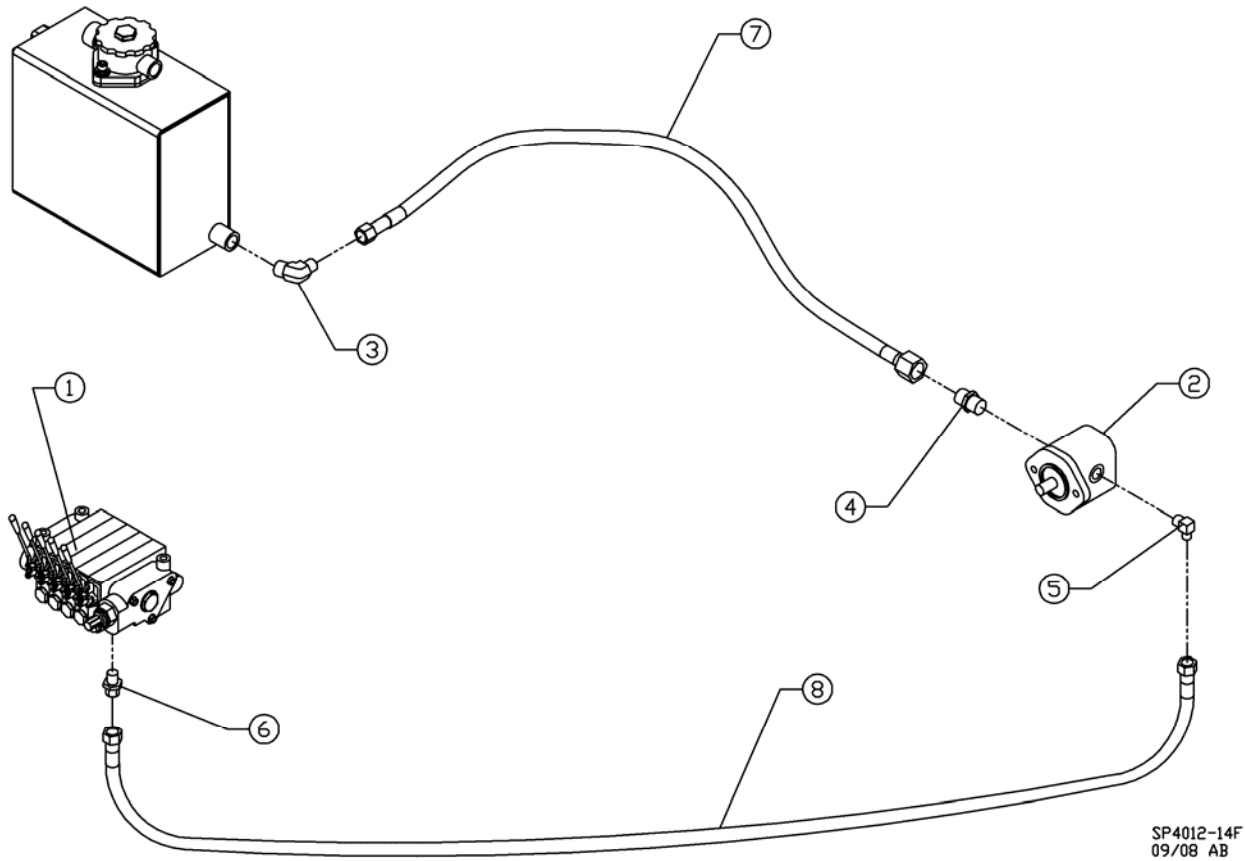

STEERING HYDRAULIC ASSEMBLY
 (ALL WHEEL DRIVE)

ITEM NO	PART NO	DESCRIPTION	QTY
1	0300199	Work Section	1
2	0300105W	Hydraulic Cylinder – 2 x 6	1
3	0300257	3/8 JIC- 1/2 ORB - 6400-6-8	2
4		1/2" O-Ring - 3/8" JIC 90°	2
5	H250426	Hose Assembly	1
6	H250425	Hose Assembly	2

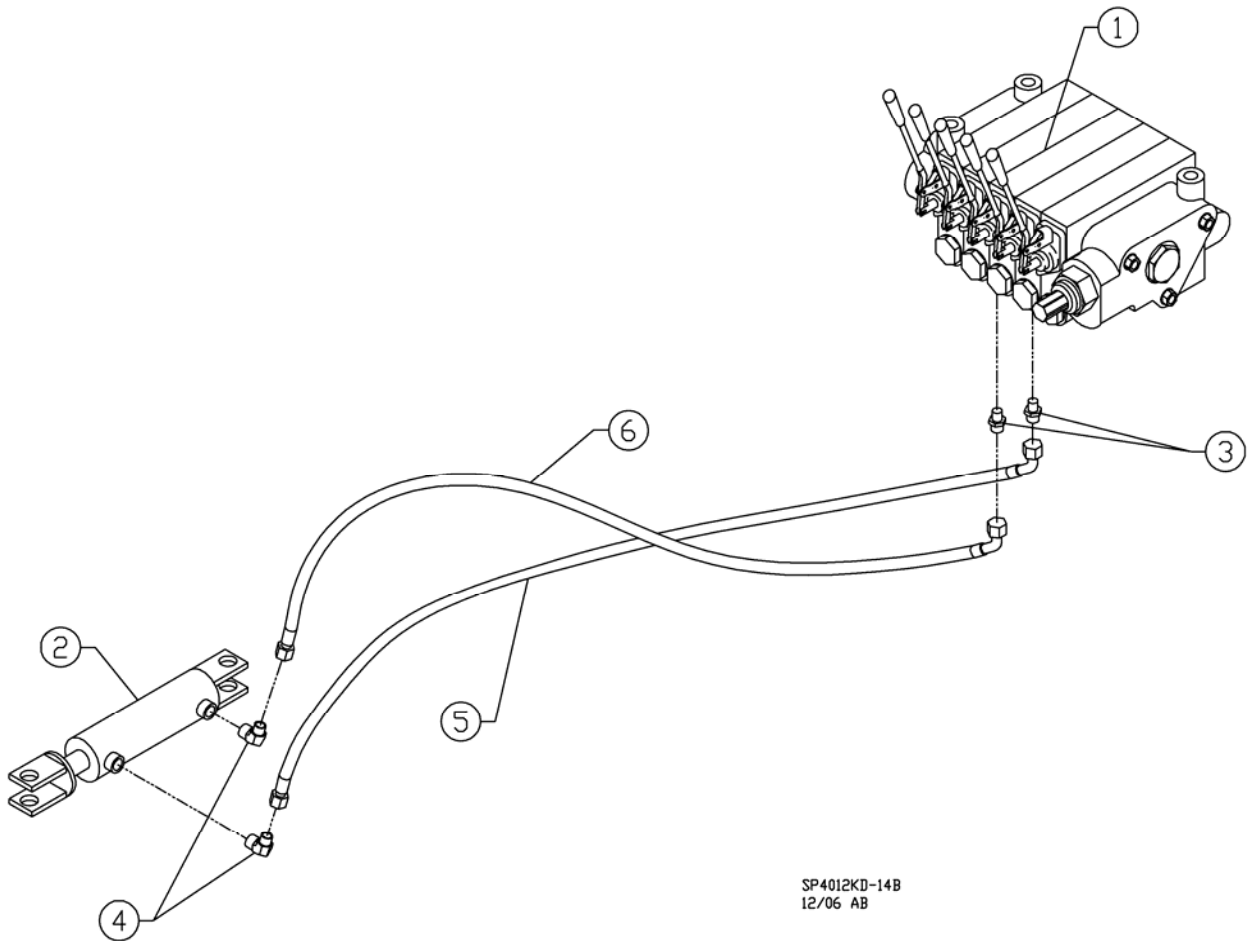

SP4012KD-14B
 12/06 AB

TRACTION HYDRAULIC ASSEMBLY
 (ALL WHEEL DRIVE)

ITEM NO	PART NO	DESCRIPTION	QTY
1	0300199	Work Section	1
2	0300138	Vickers Needle Cartridge	1
3	0300127C	Deltroll Freewheel Valve Ctg	1
4	0300128	2500 Series-Parallel Module	1
5	0300120A	C/B Cartridge Valve – CBCG-LKN	2
6	0300118A1	Hyd Mtr - 2500-4 Drv-2 Mts-RH	2
7	0300118A11	Hyd Mtr - 2500-4 Drv 2 Mtrs-LH	2
8	0300128A	2500 Flow Divider Cartridge	1
9	0300128B	2500 4W 2P Cartridge	1
10	0300128C	2500 3W 2P Cartridge	1
11	0300128D	2500 Solenoid	2
12	0300257	3/8 JIC- 1/2 ORB - 6400-6-8	2
13	0300211	3/8 JIC-5/8 ORB - 6400-6-10	8
14	0300237	3/8 JIC-3/8 ORB - 6400-6-6	6
15	0300128E	SPC2	1
16		Hose Assembly	1
17		Hose Assembly	1
18		Hose Assembly	1
19		Hose Assembly	1
20		Hose Assembly	1
21		Hose Assembly	1
22		Hose Assembly	1
23		Hose Assembly	1

TRACTION HYDRAULIC ASSEMBLY
(ALL WHEEL DRIVE)

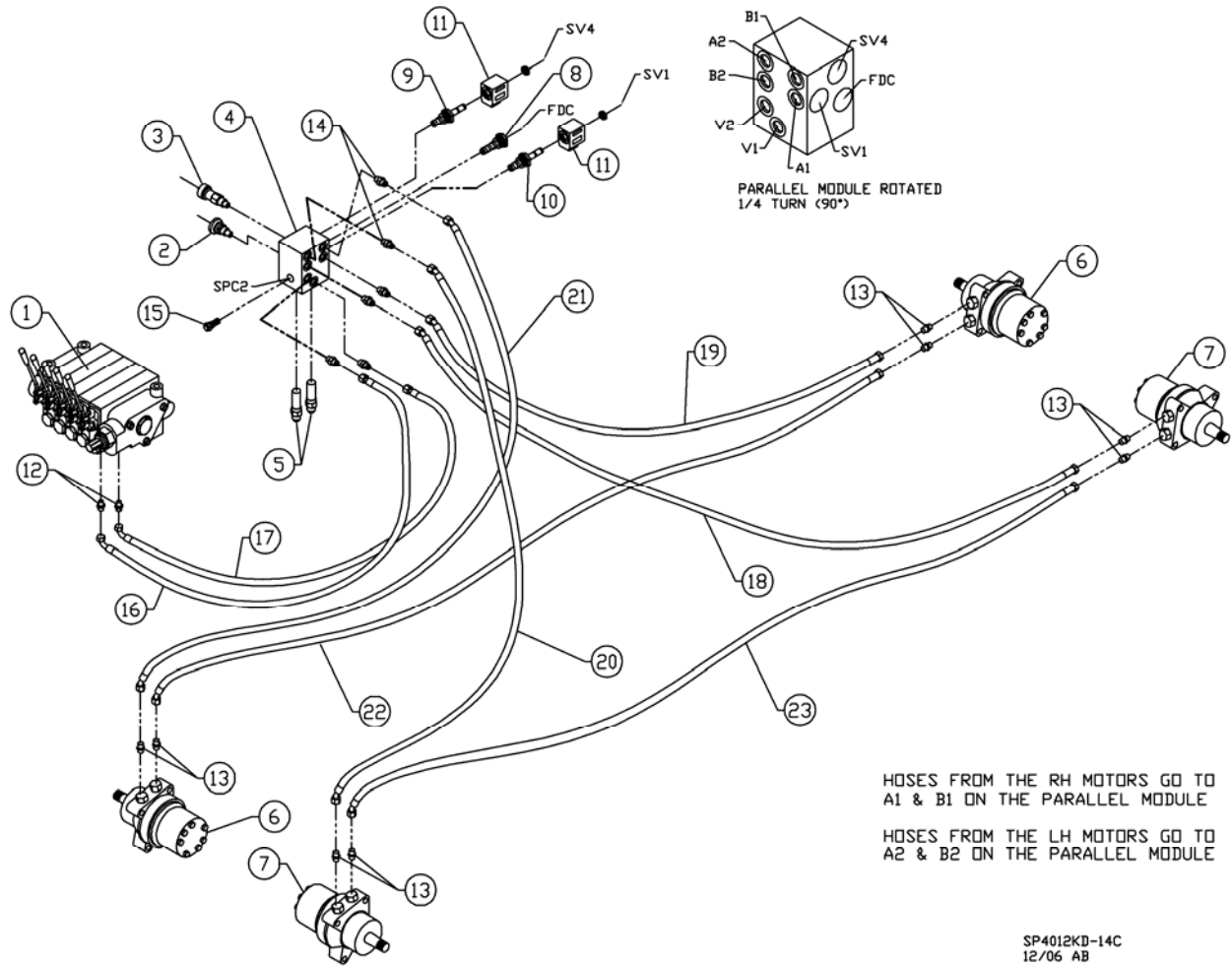

LIFT HYDRAULIC ASSEMBLY

ITEM NO	PART NO	DESCRIPTION	QTY
1	0300199	Work Section	1
2	0300122	Lift Valve Body - ECB	1
3	0300120	C/B Cartridge Valve – CBCA-LHN	1
4	0300105F	Hydraulic Cylinder - 3x12	1
5	0300257	3/8 JIC- 1/2 ORB - 6400-6-8	2
6	0300224	1/2FP-1/2FP-1/2MPTee5602-8	1
7	0300231	1/2MP-3/8MP Nipple - 5404-8-6	1
8	0300210	3/8 MP - 3/8 JIC - 2404-6-6	1
9	0300213	3/8 JIC - 1/4 MP 90 - 2501-6-4	1
10	H250414	Hose Assembly	1
11	H250413	Hose Assembly	1
12	H250412	Hose Assembly	1

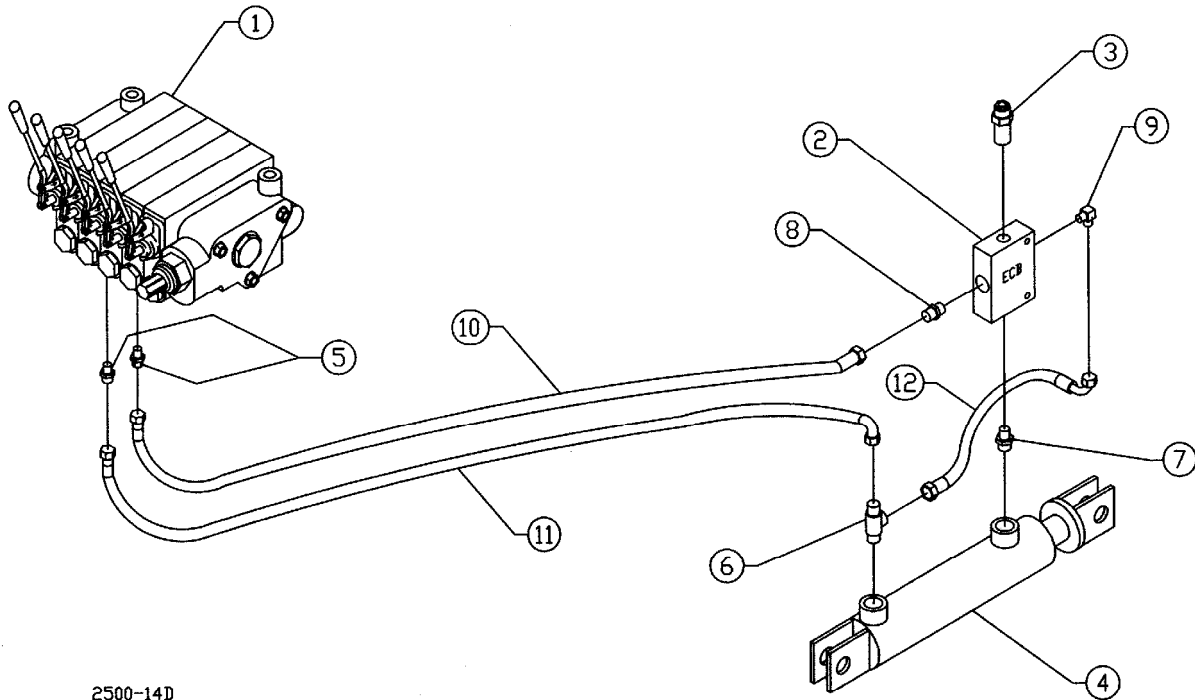

2500-14D

BLADE HYDRAULIC ASSEMBLY
 OPTION

ITEM NO	PART NO	DESCRIPTION	QTY
1	0300199	Work Section	1
2	0300105A	Hydraulic Cylinder – 2 x 4	1
3	0300257	3/8 JIC- 1/2 ORB - 6400-6-8	2
4		1/2" O-Ring - 3/8" JIC 90°	2
5		Hose Assembly	1
6		Hose Assembly	1

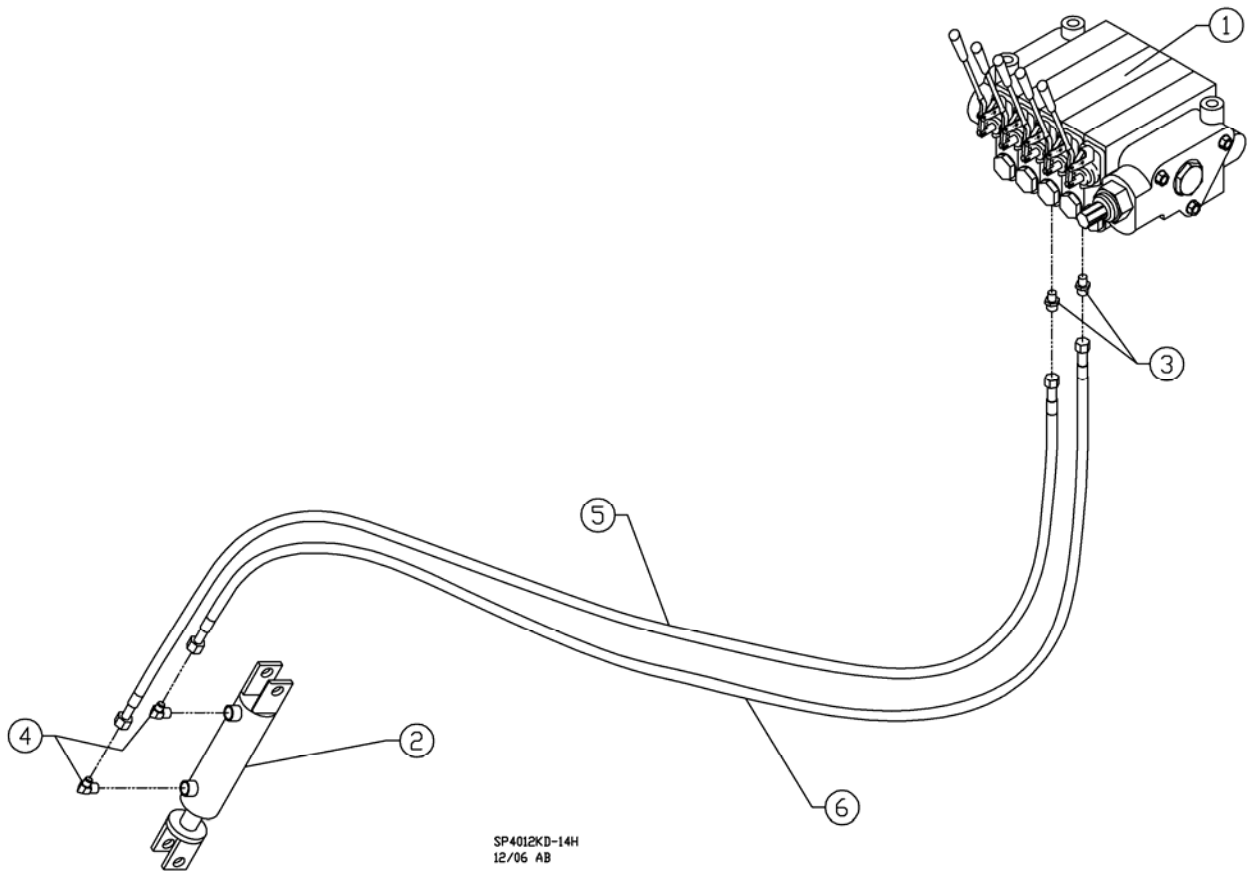

SWING HYDRAULIC ASSEMBLY

ITEM NO	PART NO	DESCRIPTION	QTY
1	0300199	Work Section	1
2	0300138	Vickers Needle Cartridge	1
3	0300127A	25-4 Swg Mnfld with Ndle Cvty	1
4	0300120A	C/B Cartridge Valve – CBCG-LKN	2
5	0300105	Hydraulic Cylinder - 2x4	2
6	0300257	3/8 JIC- 1/2 ORB - 6400-6-8	8
7	0300219	1/2 JIC - 1/2 ORB 90 - 6801-8	4
8	H250416	Hose Assembly	1
9	H250410	Hose Assembly	1
10	H250407	Hose Assembly	1
11	H250409	Hose Assembly	1
12	H250408	Hose Assembly	1
13	H250406	Hose Assembly	1

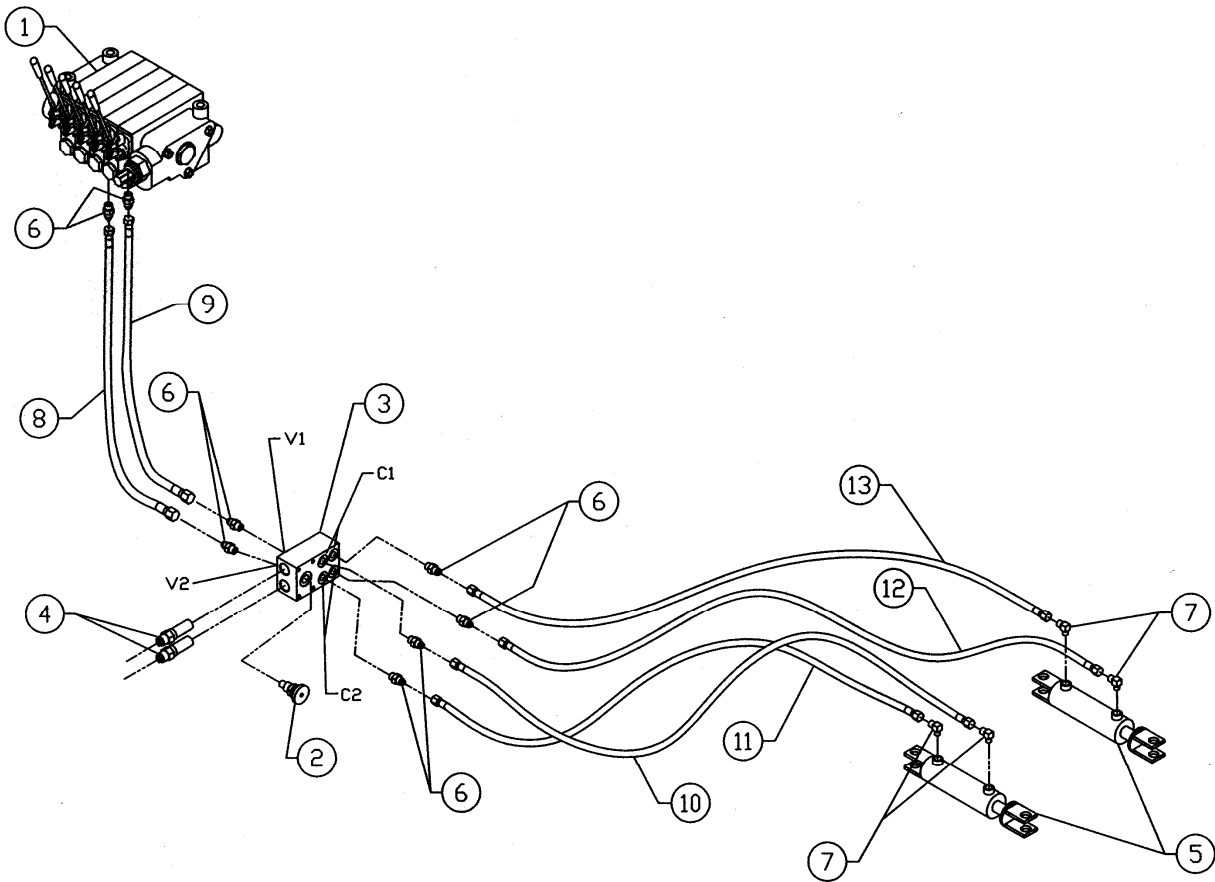

2500-14A_B
 03/04 AB

HYDRAULIC RETURN ASSEMBLY

ITEM NO	PART NO	DESCRIPTION	QTY
1	0300199	Work Section	1
2	0300135E	Hydraulic In Tank Filter STF	1
3	0300135F	Hydraulic In Tank Filter Element	1
4	0300266A	Hydraulic Site Gauge w/Temp	1
5	0300236	1/2 JIC-1/2 ORB- 6400-8	1
6	0300245A	1/2 JIC- 3/4 ORB - 6400-8-12	1
7	0150712H	SHCS 7/16 x 1-1/2 NC GR 8	2
8	0150412	7/16 Lock Washer	2
9	0150303B	7/16 Flat Washer	2
10	H250403	Hose Assembly	1

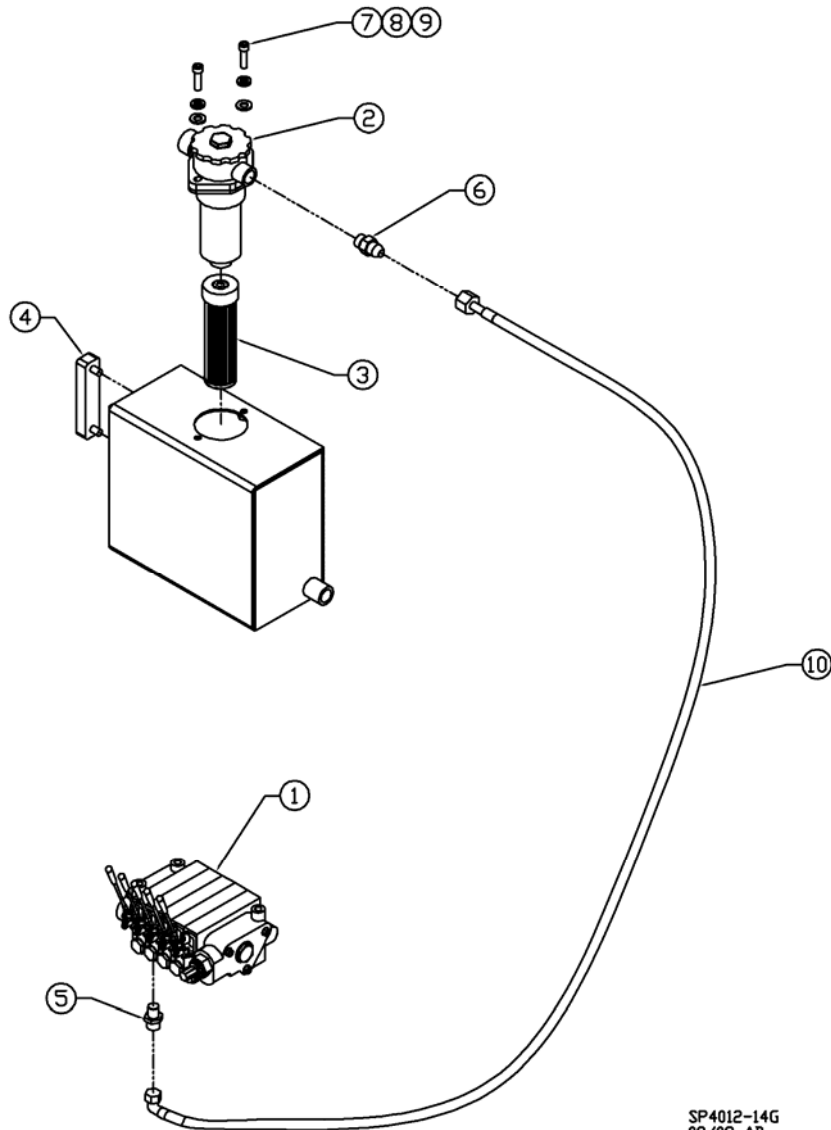

SP4012-14G
 09/08 AB

CONTROL VALVE ASSEMBLY

ITEM NO	PART NO	DESCRIPTION	QTY
1	0300199F	Work Section - SVS1GA1AA	4
2	0300199G	Valve Section - SVH1BA1AA	1
3	0300199H	Prince Inlet Section - SVI	1
4	0300199I	Outlet Section – SVE	1
5	0300064	Relief Valve	1
6	0300261	Steel Plug, 1/2 SAE	2
7	0300072	O-Ring	1
8	0300069	Back-Up Washer	1
9	0300073	O-Ring	1
10	0300074	O-Ring	1
11	0300075	O-Ring	14
12	0300065	Relief Plug	10
13	0300199L	Valve Spool End Cap	5
14	0300060	Handle Flange	5
15	0300199M	Prince Handle Linkage	5
16	0300199N	Prince Valve Spool Extension	5
17	0300199K1	Valve Handle Kit	5
18	0300076	O-Ring	4
19	0300070	Spool Back-Up Washer	10
20	0300077	O-Ring	10
21	0300078	O-Ring	16
22	0300066	Load Check Poppet	5
23	0300067	Spring	5
24	0300068	Load Check Plug	5
25	0300071	Back-Up Washer	10
26	0300079	O-Ring	10

NOTES:

1. SVS work section seal kit - P/N 0300199ZA - Includes items 11,18,20,21,25.
2. SVH work section seal kit - P/N 0300199ZB - Includes items 10,11,20,21,25.
3. SVI inlet section seal kit - P/N 0300199ZC - Includes items 10,11.

CONTROL VALVE ASSEMBLY

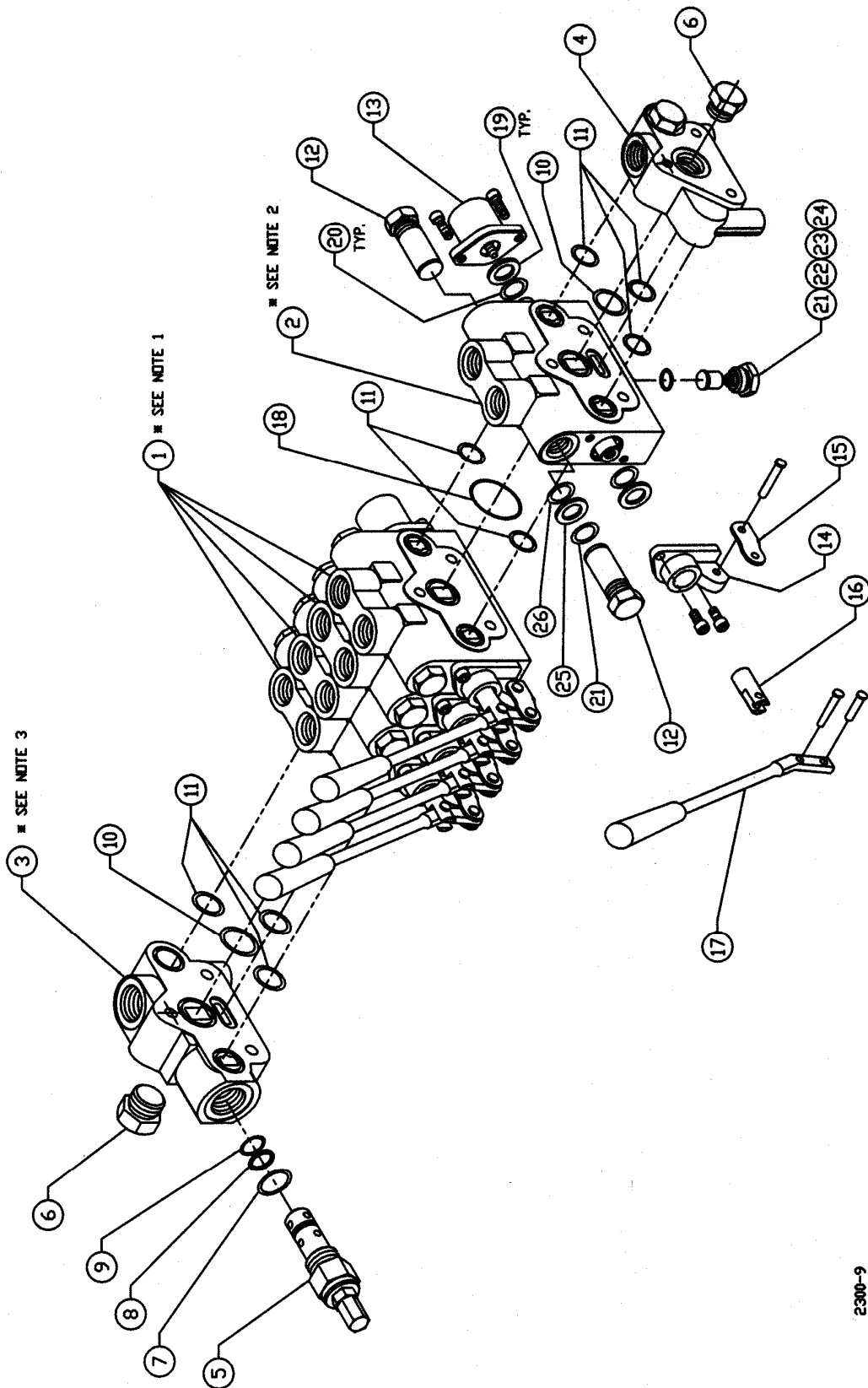

2300-9

STEERING HYDRAULIC ASSEMBLY
 WITH 2-WHEEL DRIVE OPTION

ITEM NO	PART NO	DESCRIPTION	QTY
1	0300199	Work Section	1
2	0300105A	Hydraulic Cylinder – 2x4	1
3	0300257	3/8 JIC- 1/2 ORB - 6400-6-8	2
4	0300279	3/8JIC-1/2ORB45 - 6802-6-8	2
5	H250426	Hose Assembly	1
6	H250425	Hose Assembly	2

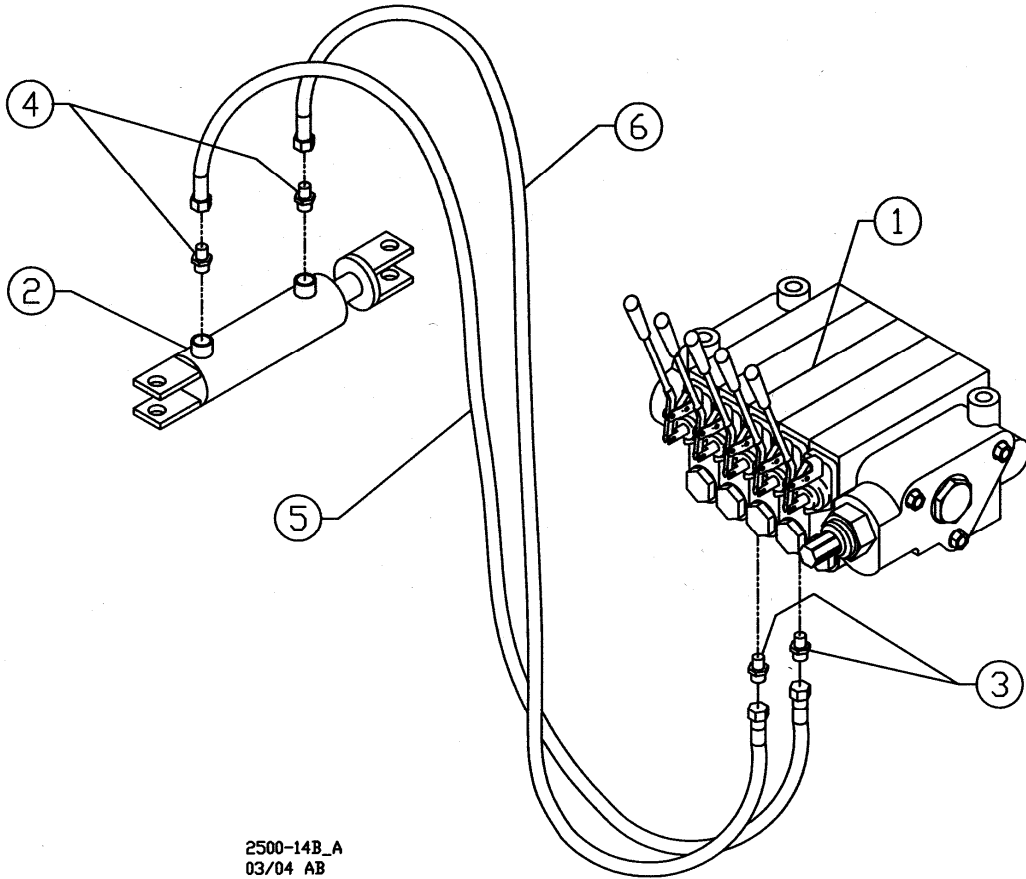

2500-14B_A
 03/04 AB

TRACTION HYDRAULIC ASSEMBLY
WITH 2-WHEEL DRIVE OPTION

ITEM NO	PART NO	DESCRIPTION	QTY
1	0300199	Work Section	1
2	0300138	Vickers Needle Cartridge	1
3	0300127C	Deltroll Freewheel Valve Ctg	1
4	0300128	2500 Series- Parallel Module	1
5	0300120A	C/B Cartridge Valve – CBCG-LKN	2
6	0300118A1	Hyd Mtr - 2500-4 Drv 2 Mts-RH	1
7	0300118A11	Hyd Mtr - 2500-4 Drv 2 Mtrs-LH	1
8	0300128A	2500 Flow Divider Cartridge	1
9	0300128B	2500 4W 2P Cartridge	1
10	0300128C	2500 3W 2P Cartridge	1
11	0300128D	2500 Solenoid	1
12	0300257	3/8 JIC- 1/2 ORB - 6400-6-8	2
13	0300211	3/8 JIC-5/8 ORB - 6400-6-10	4
14	0300237	3/8 JIC-3/8 ORB - 6400-6-6	6
15	H250421	Hose Assembly	1
16	H250404	Hose Assembly	1
17	H250417	Hose Assembly	2
18	H250418	Hose Assembly	2

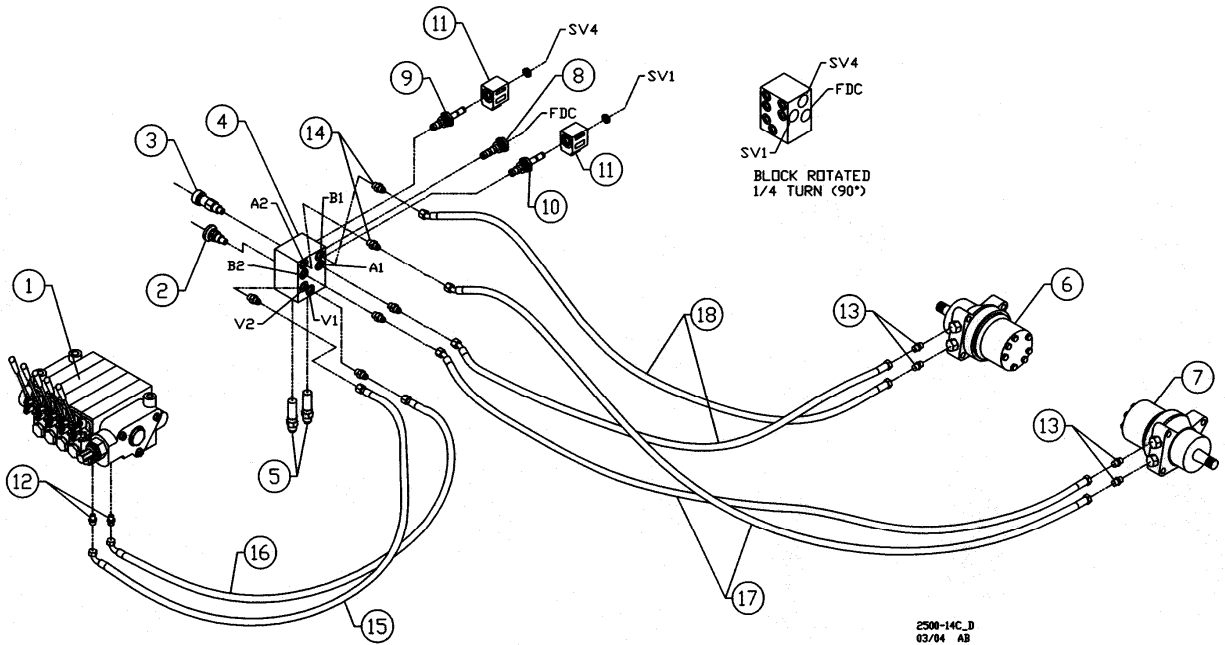

TONGUE EXTENSION HYDRAULIC ASSEMBLY

WITH TONGUE EXTENSION OPTION (ONLY AVAILABLE WITH 2-WHEEL DRIVE OPTION)

ITEM NO	PART NO	DESCRIPTION	QTY
1	0300199	Work Section	1
2	0300105B	Hydraulic Cylinder - 2 1/2 x 30	1
3	0300257	3/8 JIC- 1/2 ORB - 6400-6-8	2
4	0300215	3/8JIC-1/2MP90 - 2501-6-8	2
5	H250423	Hose Assembly	1
6	H250424	Hose Assembly	1

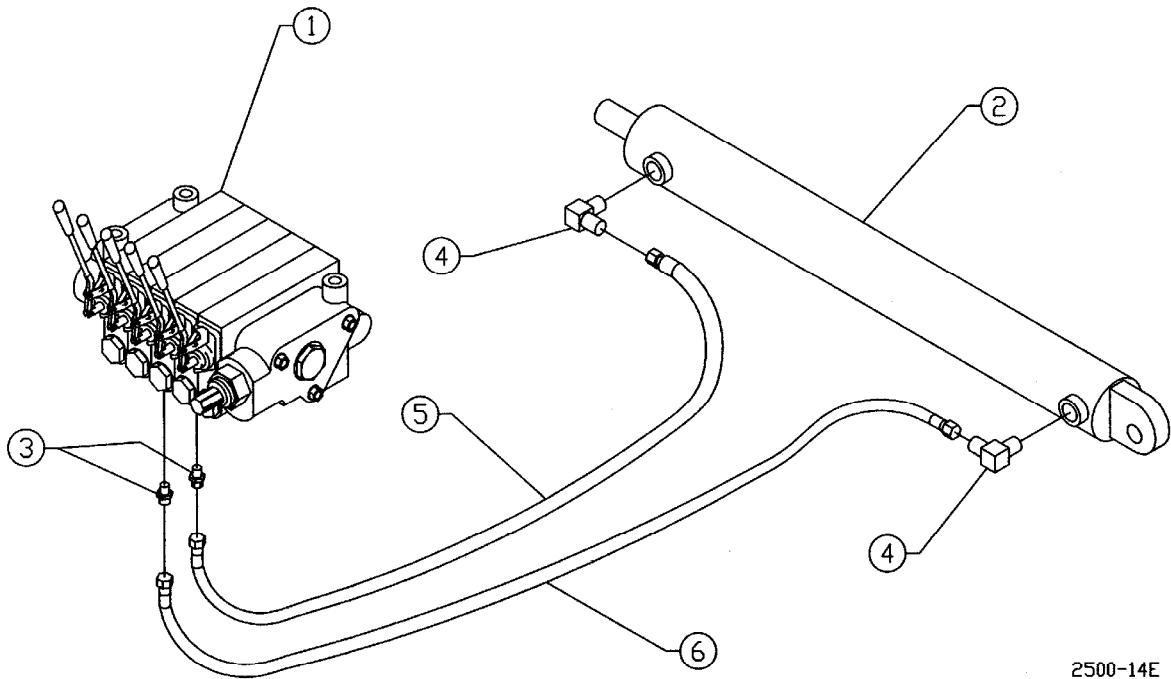

2500-14E

ALL WHEEL DRIVE

ITEM NO	PART NO	DESCRIPTION	QTY
1	05500091	Tire Assembly 25-4 5 Lug	2
2	0550102	Lug Nut – 1/2-20	10
3	14060030	Weldment, Mount, AWD Motor, RH	1
4	14060031	Weldment, Mount, AWD Motor, LH	1
5	0550208	E/Z Lube Grease Seal	2
6	0550209	Inner Bearing - 3500#	2
7	0550210	Inner Bearing Race - 3500#	2
8	0550009H	Rear Tapered Hub 25-4	2
9	0550213	Outer Bearing Race - 3500#	2
10	0550214	Outer Bearing - 3500#	2
11	0550215	Spindle Washer	2
12	0550216	Spindle Jam Nut – 1”-14	2
13	0550217	Tang Washer	2
14	0550218	Grease Cap – E/Z Lube - 3500#	2
15	0550219	Rubber Plug for EZ Lube Cap	2
16	14060033	Assy, Steering Linkage, AWD	1
17	12G-1010	Shoulder Bolt, 5/8” x 1 1/4” (1/2”-13)	2
18	0150305	5/8 Flat Washer	2
19	0150304	1/2 Flat Washer	10
20	0150206	1/2 Lock Nut	2
21	0300118A11	Hyd Mtr - 2500-4 Drv 2 Mtrs-LH	1
22	0300118A1	Hyd Mtr - 2500-4 Drv 2 Mtrs-RH	1
23	0300105W	Hydraulic Cylinder 2 x 6	1
24	0300105O	Prince Cyl. Pin - Long	2
25		Hitch Pin Clip (with 0300105O)	4
26	0150801	Hardened Spring Bushing – 1”	2
27	0150805	Hardened Spring Bushing – 5/8”	2
28	0150106G	1/2”-13 x 2 3/4” HHCS	8
29		Woodruff Key – 1/4” x 1” (with motor)	2
30	0150304	1/2 Flat Washer	8
31		Axle Nut – 1” Slotted Hex (with motor)	2
32	0150501	Cotter Pin – 3/16 x 2	2
33		Weld-on Seal Ring	2

ALL WHEEL DRIVE

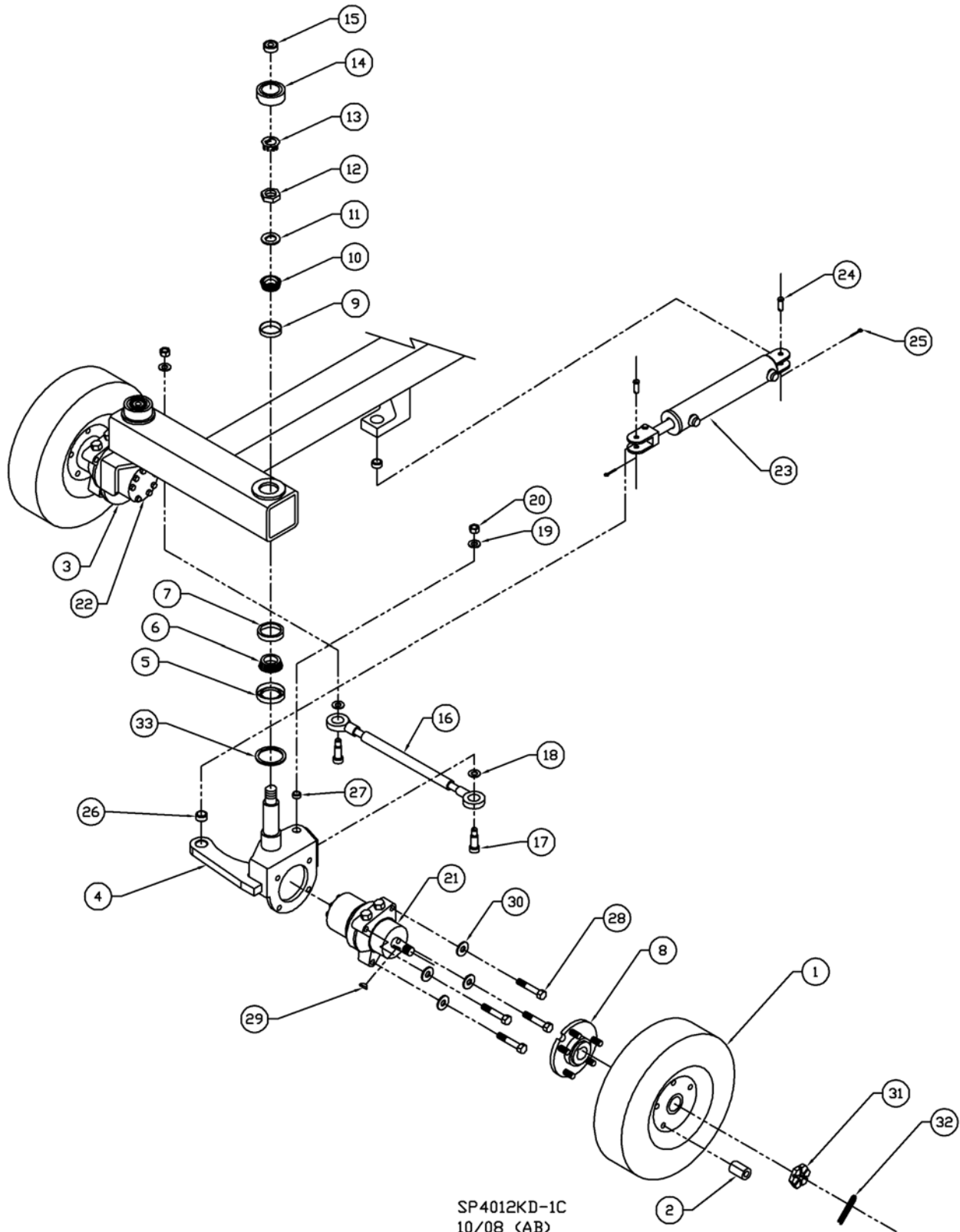

(OPTIONAL 2-WHEEL DRIVE W/TONGUE EXTENSION)

ITEM NO	PART NO	DESCRIPTION	QTY
1	05500091	Tire Assembly 25-4 5 Lug	2
2	0550102	Lug Nut - 1/2-20	10
3	2300289	R/H Steering Frame	1
4	2300290	L/H Steering Frame	1
5	0550208	E/Z Lube Grease Seal	2
6	0550209	Inner Bearing - 3500#	2
7	0550210	Inner Bearing Race - 3500#	2
8	0550212	Hub w/Cups & Studs	2
9	0550213	Outer Bearing Race – 3500#	6
10	0550214	Outer Bearing – 3500#	6
11	0550215	Spindle Washer	4
12	0550216	Spindle Jam Nut - 1”-14	4
13	0550217	Tang Washer	4
14	0550218	Grease Cap - E/Z Lube – 3500#	2
15	0550219	Rubber Plug for EZ Lube Cap	2
16	3504133	Steering Linkage	1
17	2300280	Weld-on Seal Ring	2
18	12G-1010	Shoulder Bolt, 5/8” x 1 1/4" (1/2-13)	2
19	0150305	5/8 Flat Washer	2
20	0300105	Hydraulic Cylinder - 2x4	1
21	0150801	Hardened Spring Bushing - 1”	2
22	0300105N	Prince Cyl. Pin – Short	2
23		1/4”-28 x 2” HHCS	4
24	2300158	Ground Stake Rod - 2500	1
25	0150604	Lock Pin - 3/8 x 2 3/4	1
26	0150805	Hardened Spring Bushing - 5/8"	2
27	0150304	1/2" Flat Washer	2
28	0550104	Grease Seal – 10-9	2
29	0550109	End Cap – 3500#	2
30	0150206	1/2-13 Lock Nut	2

(OPTIONAL 2-WHEEL DRIVE W/TONGUE EXTENSION)

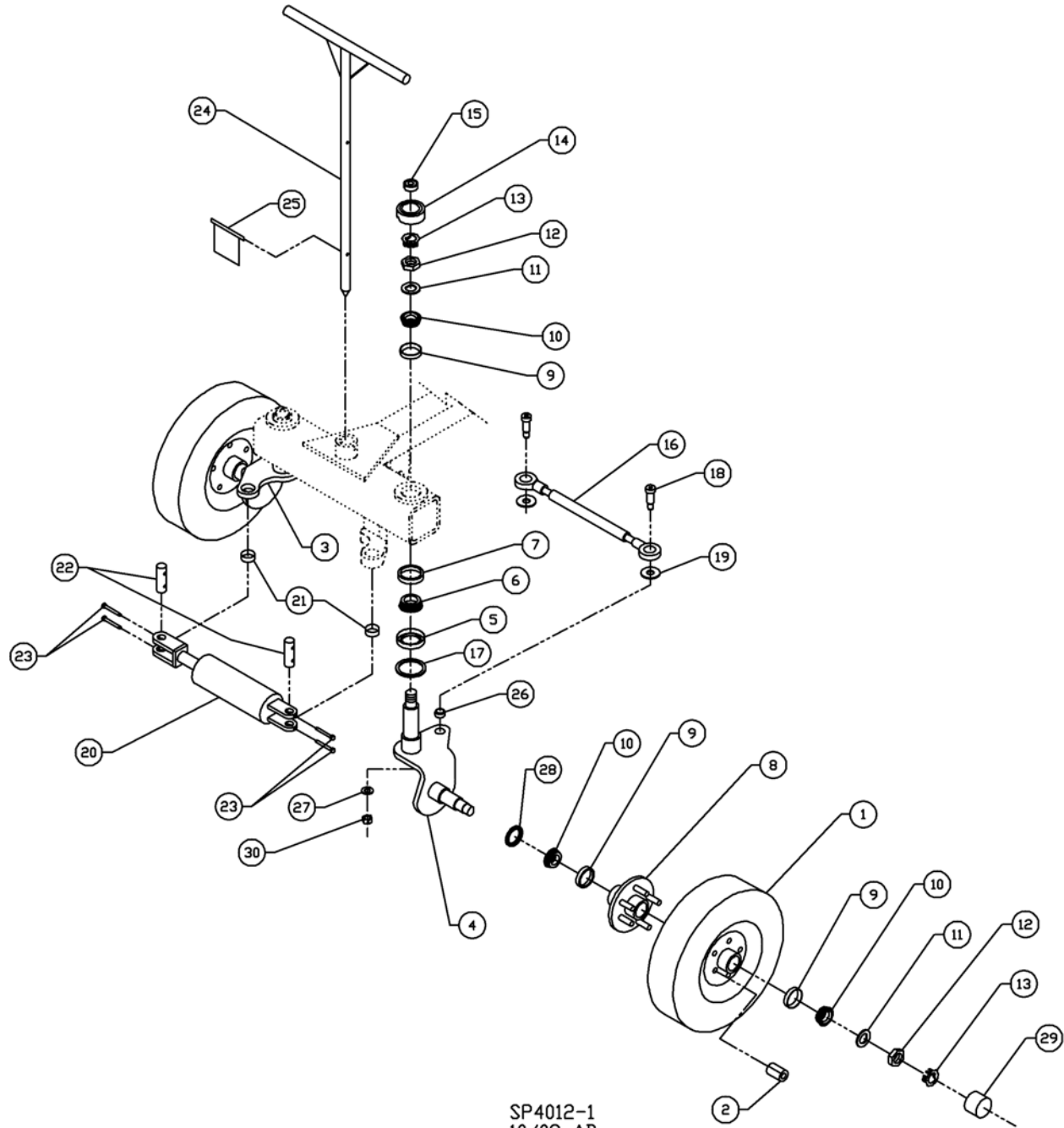

SP4012-1
 10/08 AB

ITEM NO	PART NO	DESCRIPTION	QTY
1	0300118A1	Hyd Mtr - 2500-4 Drv 2 Mtrs-RH	1
2	0300118A11	Hyd Mtr - 2500-4 Drv 2 Mtrs-LH	1
3	0150304	1/2 Flat Washer	8
4	0150106G	1/2-13 x 2 3/4" HHCS	8
5	0150206	1/2-13 Lock Nut	8
6	0550009H	Rear Tapered Hub 25-4	2
7	0550009I	Tire Assembly 25-4 5 Lug	2
8	0550102	Lug Nut - 1/2-20	10
9	0550009E	Slotted Hex Nut - 1"-14	2
10	0150501	Cotter Pin - 3/16" x 2"	2

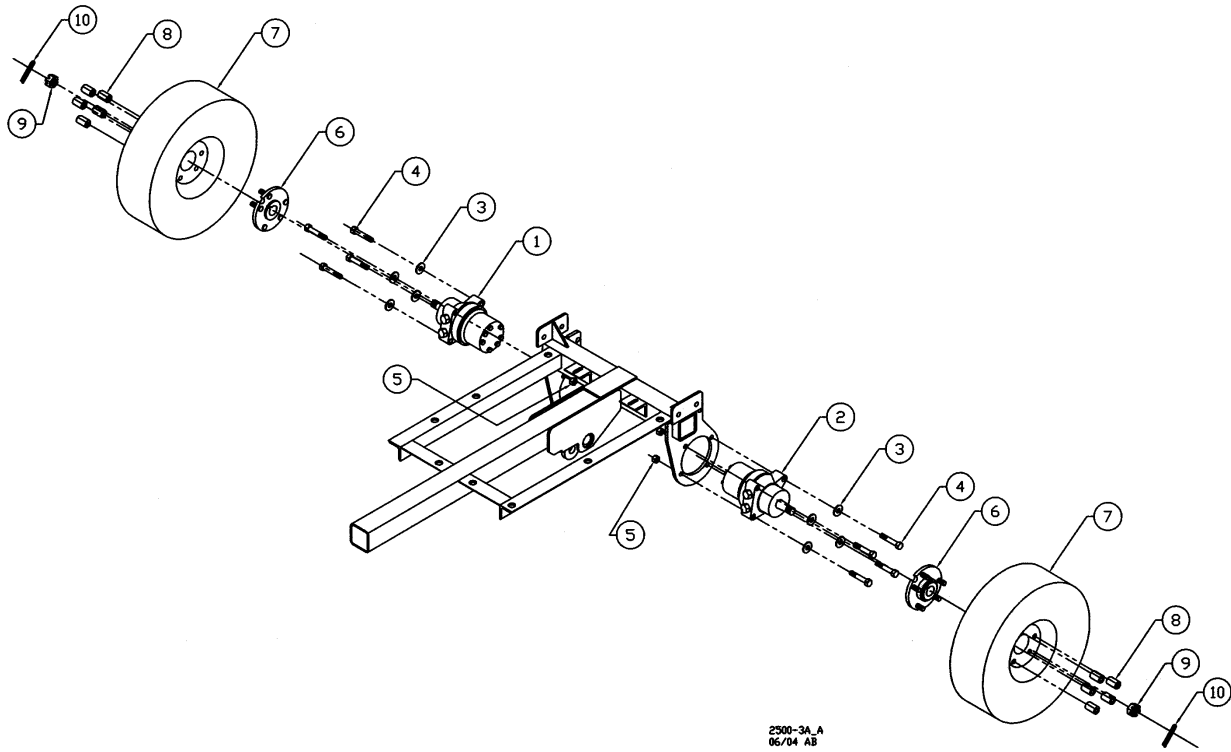

DUAL WHEEL ASSEMBLY

(Parts List For Two Assemblies, Only One Shown.)

ITEM NO	PART NO	DESCRIPTION	QTY
1	2500357A	Dual Wheel Hub – 5 Bolt	2
2	2500358A	Dual Wheel Spacer – 5 Bolt	2
3	05500091	Tire Assembly 25-4 5 Lug	2
4	0550102	Lug Nut – 1/2-20	10
5	0150308	1” SAE Flat Washer	2
6	0150409	1” Lock Washer	2
7	0150150A	1-8 x 7” HHCS	2

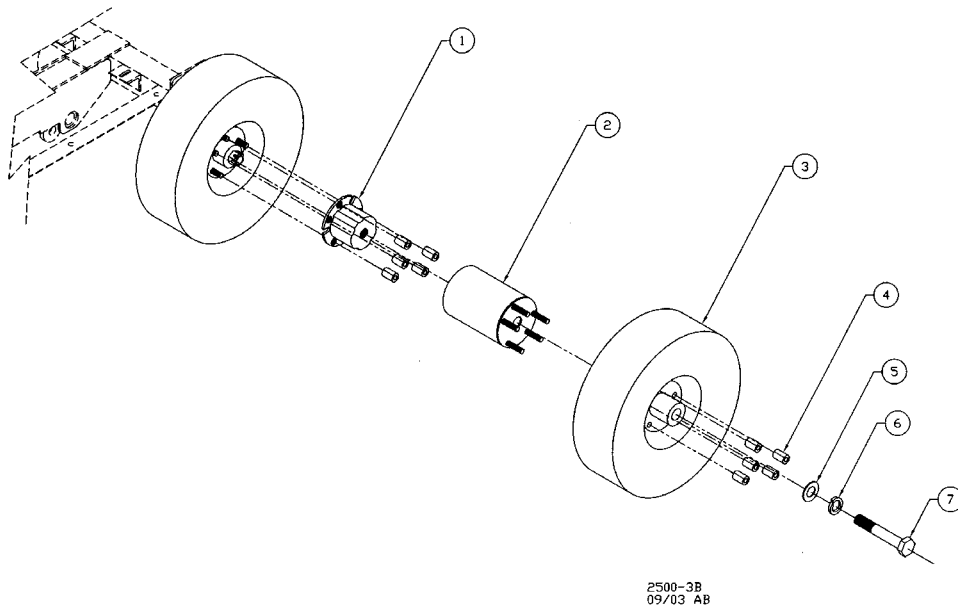

ASSEMBLY INSTRUCTIONS

1. Remove lug nuts and install inner hub.
2. Replace lug nuts and tighten.
3. Bolt wheel spacer to dual wheel and tighten with new lug nuts.
4. Place dual wheel up to rear wheel and bolt through center of wheel to inner hub.
5. Tighten.
6. Repeat for other side.

**LOWER PIVOT ASSEMBLY
ALL WHEEL DRIVE**

ITEM NO	PART NO	DESCRIPTION	QTY
1	2300189	Lift Pivot Shaft -2500	1
2	0150801	Hardened Spring Bushing - 1"	8
3	0150308	1" SAE Flat Washer	2
4	0150209	1-14 Hex Castle Nut	2
5	0150501	Cotter Pin - 3/16" x 2"	2
6	0300105F	Hydraulic Cylinder - 3x12	1
7	0300105O	Prince Cyl. Pin - Long	2
8		Hitch Pin Clip (with 0300105O)	2
◆ 9	2500162	Side Pivot Tube 2500	2
◆ 10	2500280	Side Pivot Gusset 2500	2
◆ 11	2300125	Pivot Shaft Tube 2500	1
12	0150600	Grease Fitting -1/4 NPT	3
13	H250429	Grease Hose Assembly - 42"	1
14	H250428	Grease Hose Assembly - 41"	1
15	H250427	Grease Hose Assembly - 40"	1
16	0300346	1/4 MJIC - 1/8 NPT- 2405-4-2	3

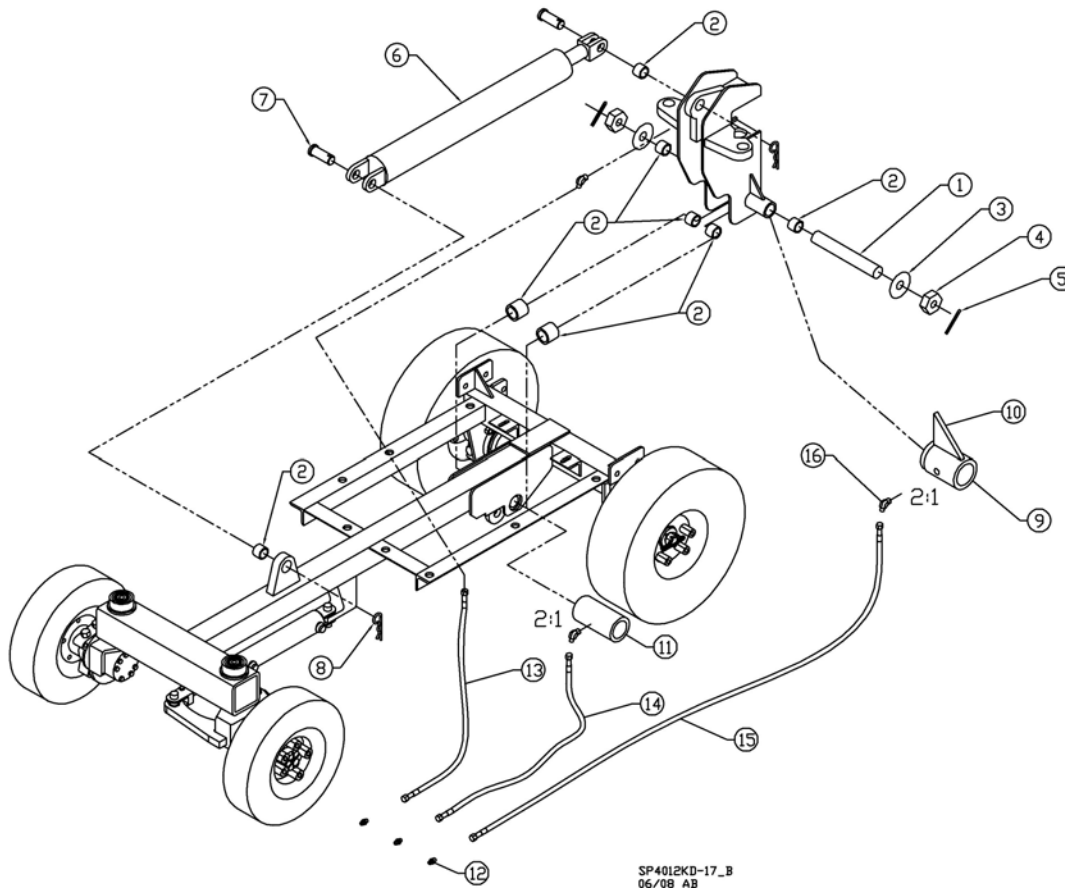

SP4012KD-17_B
06/08 AB

◆ PARTS # 9 & 10 ARE WELDED TO THE PIVOT ASSEMBLY AFTER THE BOOM IS LEVEL
#11 IS WELDED IN THE FRAME ASSEMBLY

UPPER PIVOT ASSEMBLY

ITEM NO	PART NO	DESCRIPTION	QTY
1	2300159	Swing Pivot Shaft - 1" - 23/25	1
2	0150801	Hardened Spring Bushing - 1"	4
3	0500201	Race - 23/25 # 15250	2
4	0500121	Bearing - 1" - 23/25 # 15100	2
5	0500407	Seal - 23/25	2
6	2300255	Top Pivot Inner Bushing - 2500	1
7	2300256	Bottom Pivot Bushing - 2500	1
8	0150208	1-14 Hex Jam Nut	2
9	0150209	1-14 Hex Castle Nut	1
10	0150501	Cotter Pin - 3/16" x 2"	1
11	0150123	5/16-18 x 3/4" SHCP	6
12	0150124	5/16-18 x 3/4" FHSCP	6
13	2300257	Top Pivot Bushing - 2500	1
14	0300105N	Prince Cyl. Pin - Short	4
15		1/4"-28 x 2" HHCS	8
16	0500500	Snap Ring for 2500 Pivot 2.5"	2
17	0150308	1" SAE Flat Washer	1
18	0150600	Grease Fitting - 1/4 NPT	1
19		Pop-Out Valve	1
◆ 20	2300107	Boom Pivot Tube	1

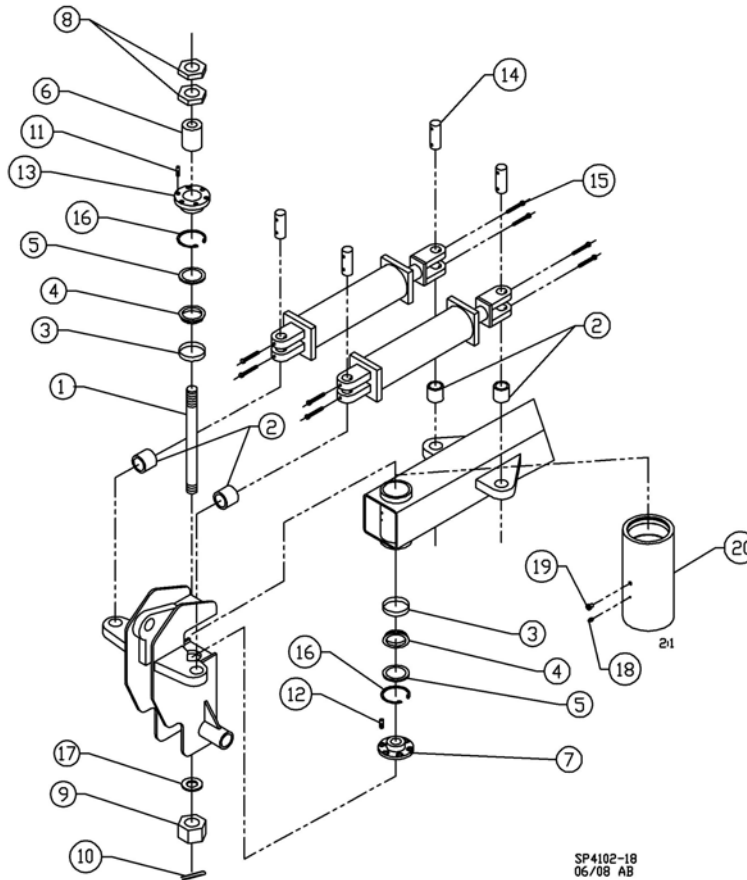

SP4102-18
 06/08 AB

◆ PART #20 IS WELDED IN THE PIVOT ASSEMBLY

LOWER PIVOT ASSEMBLY
TWO WHEEL DRIVE WITH TONGUE EXTENSION

ITEM NO	PART NO	DESCRIPTION	QTY
1	2300189	Lift Pivot Shaft - 2500	1
2	0150801	Hardened Spring Bushing - 1"	8
3	0150308	1" SAE Flat Washer	2
4	0150209	1-14 Hex Castle Nut	2
5	0150501	Cotter Pin - 3/16" x 2"	2
6	0300105F	Hydraulic Cylinder - 3x12	1
7	0300105O	Prince Cyl. Pin - Long	2
8		Hitch Pin Clip (with 0300105O)	2
◆ 9	2500162	Side Pivot Tube 2500	2
◆ 10	2500280	Side Pivot Gusset 2500	2
◆ 11	2300125	Pivot Shaft Tube 2500	1
12	0150600	Grease Fitting -1/4 NPT	3
13	H250429	Grease Hose Assembly - 42"	1
14	H250428	Grease Hose Assembly - 41"	1
15	H250427	Grease Hose Assembly - 40"	1
16	0300346	1/4 MJIC - 1/8 NPT- 2405-4-2	3

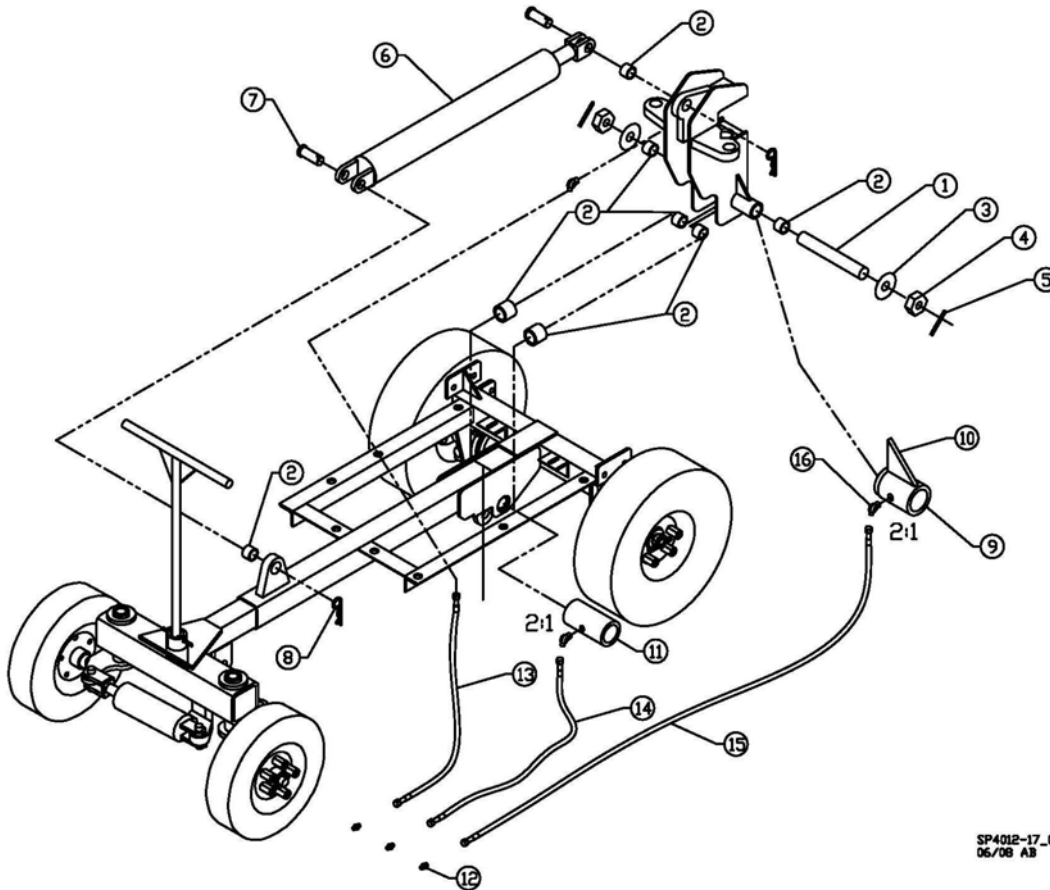

SP4012-17_C
06/08 AB

◆ PARTS # 9 & 10 ARE WELDED TO THE PIVOT ASSEMBLY AFTER THE BOOM IS LEVEL
#11 IS WELDED IN THE FRAME ASSEMBLY

ENGINE SLIDE ASSEMBLY

ITEM NO	PART NO	DESCRIPTION	QTY
1	0200133B	Kubota Engine - 33HP	1
2	14020042	Mount,Kubota,Cutter Wheel Side	1
3	14020029	Weldment,Mount,Kubota,Tank Side	1
4		10MM - 1.25 x 35MM	15
5		10MM Flat Washer	15
6	14040079	Wedlment,Engine Slide,Briggs	1
7	0150125A	5/8-11 x 2 HHCS	4
8	0150408	5/8 Lock Washer	4
9	0150305	5/8 Flat Washer	4
10	14040045	Rod,Engine Slie	2
11	0150104A	3/8-16 x 2 1/4" Hex Cap Screw	4
12	0150207	3/8-16 Lock Nut	4
13	A160T018	Key - 3/16 sq. 1 1/16	2
14	14040100	Weldment,Engagement Handle,Kubota	1
15	14040105	Weldment,Engine Rod Adjust.Mount,Kubota	1
16	0250216	Bushing JA x 7/8	2
17	0150101	# 10-24 x 3/4" SHCS	6
18	0150401	# 10 Lock Washer	6
19	14040090	Rod,Engagement	1
20	0150703A	Split Lock Collar - 7/8	2
21	14040087	Weldment,Latch Handle	1
22	0150801	Hardened Spring Bushing - 1"	4
23		HOI-125 Snap Ring	4
24	14040106	Assy,Engagement Linkage,7" Adjust	1
25	14040051	Plate,Latch,Engine Slide	1
26	0150102	1/4-20 x 1 Hex Cap Screw	1
27	0150218	1/4-20 Lock Nut	1
28	0150601	Grease Fitting - 1/4"-28 Straight	8

ENGINE SLIDE ASSEMBLY

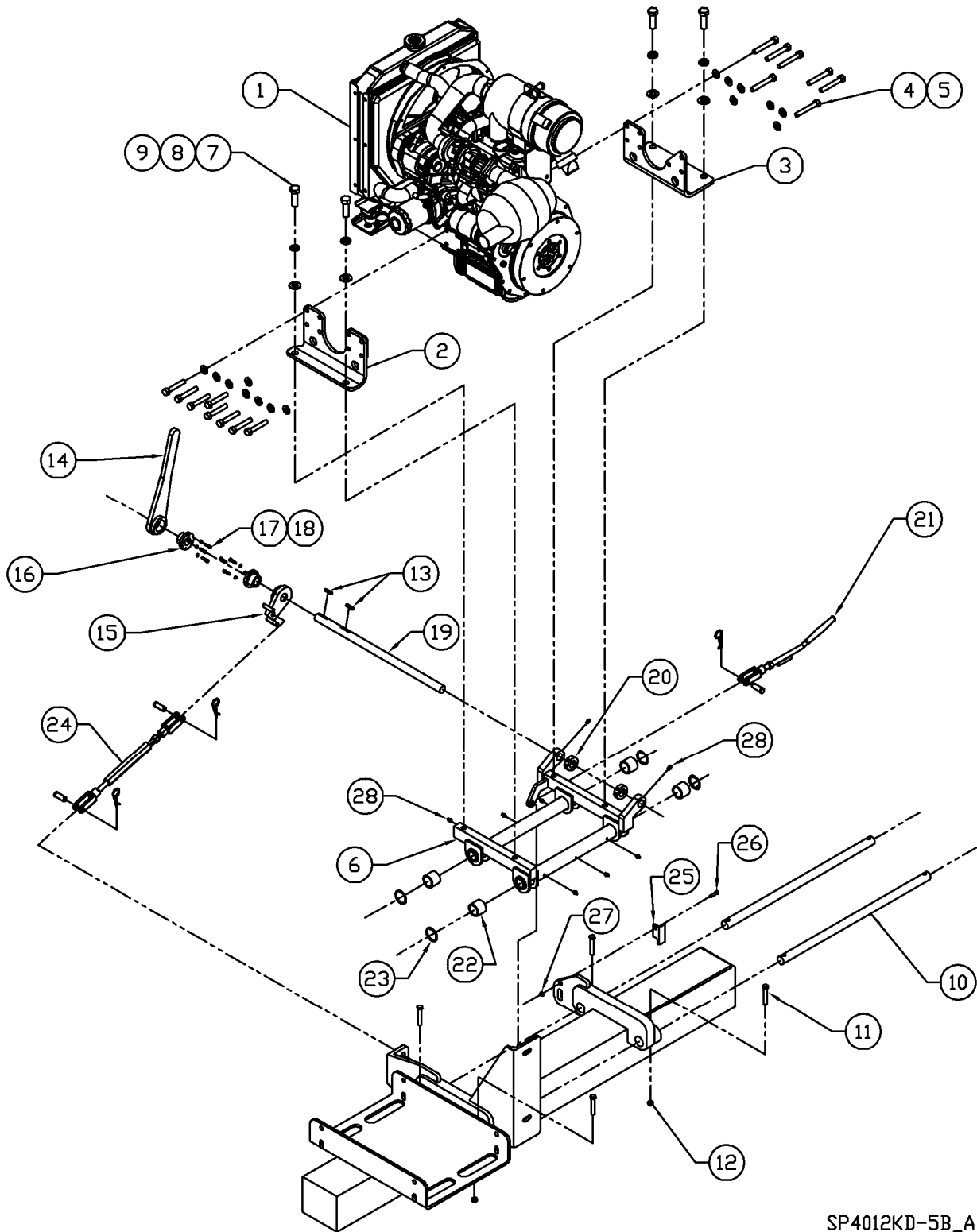

SP4012KD-5B_A
11/08 (AB)

ENGINE BELT ASSEMBLY

ITEM NO	PART NO	DESCRIPTION	QTY
1		Fly Wheel Coupling Assembly	1
2		Stub Shaft Assembly	1
3		8MM Bolt	6
4		8MM Flat Washer	6
5		10MM Bolt	2
6		10MM Flat Washer	8
7		1/4"-28 Grease Fitting	2
8	14020028	Belt Keeper Bracket	2
9		1/2"-13 x 1 1/4" SHCS	4
10		Key – 3/8" Sq. x 2 11/16"	1
11	14040108	Engine Belt Guard Base Weldment	1
12		3/8"-16 x 1" Carriage Bolt	2
13		3/8" Flat Washer	13
14		3/8"-16 Lock Nut	3
15	2500208	Belt Keeper	2
16		Belt Keeper, Long	1
17		3/8"-16 x 1" HH Bolt	10
18		3/8" Lock Washer	10
19		3/8"-16 x 1 1/4" Carriage Bolt	1
20	0400144	V-Belt – 6/3V600	1
21	0250318	Engine Sheave – 6/3V600	1
22	0250120B	Bushing – SK x 1 1/2"	1
23		1/4"-20 x 1" HH Bolt	3
24	14040109	Engine Belt Guard Cover Weldment	1
25		3/8"-16 Hex Nut (Welded inside #14040108)	8

ENGINE BELT ASSEMBLY

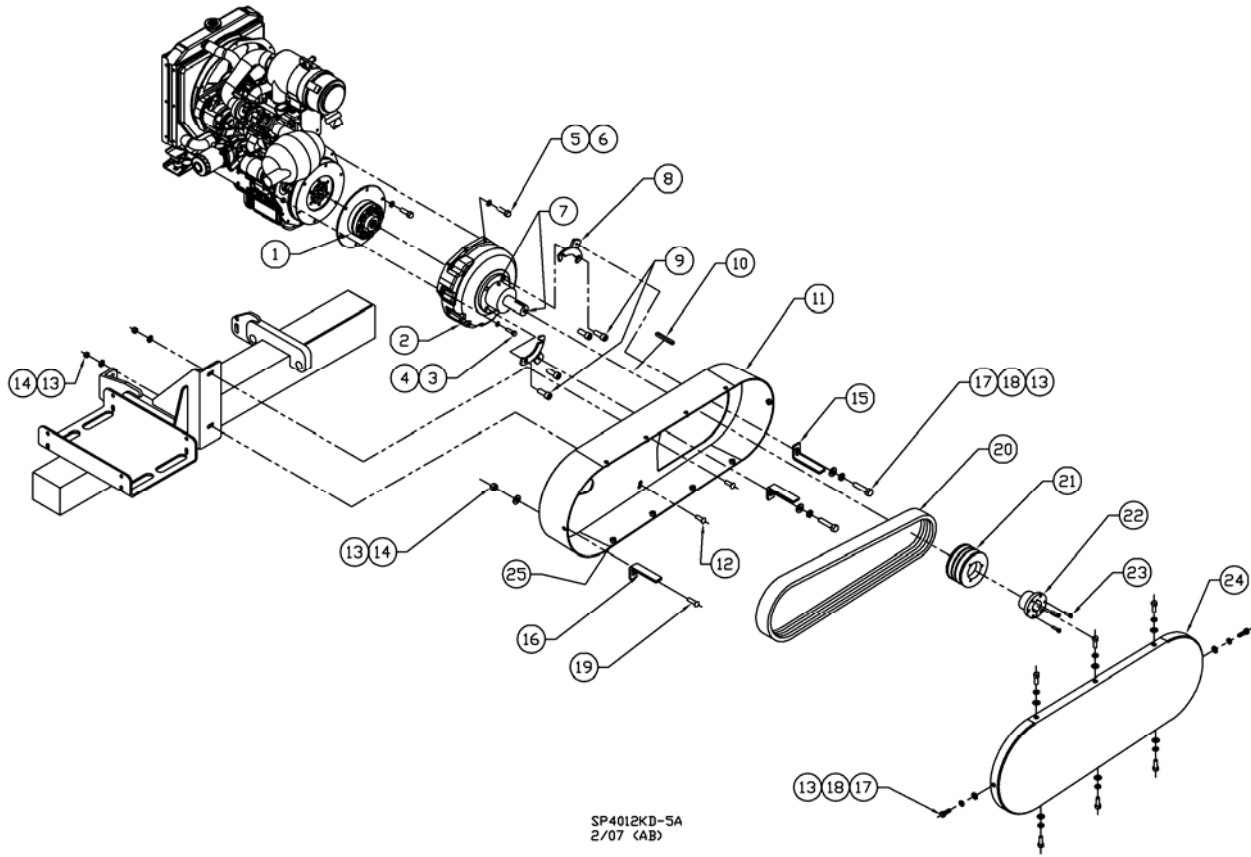

JACK SHAFT ASSEMBLY

ITEM NO	PART NO	DESCRIPTION	QTY
1	2700D185	Jackshaft – 1 11/16"	1
2	A160T011	Key - 3/8" x 1 3/4"	1
3	A160T012	Key – 3/8" x 2 1/4"	1
4	0500113	Bearing – 1 11/16"	2
5	0150125	5/8"-11 x 2 1/2" HHCS	4
6	0150305	5/8" Flat Washer	8
7	0150216	5/8"-11 Lock Nut	4
8	0250319	Pulley – 6/3V10.6	1
9	0250212	Bushing – SF x 1 11/16"	1
10	0250115F1	Tapered Bushing – 2012 x 1 11/16"	1
11	0250115A	Poly Chain® Sprocket	1
12		7/16"-14 x 1 1/2" SHC	2
13		1/2"-13 x 3 1/2" SQHD Bolt	2
14	0150206	1/2"-13 Lock Nut	8
15		1/2" Lock Washer	4
16	0150115	1/2"-13 x 4" SQHD Bolt	2

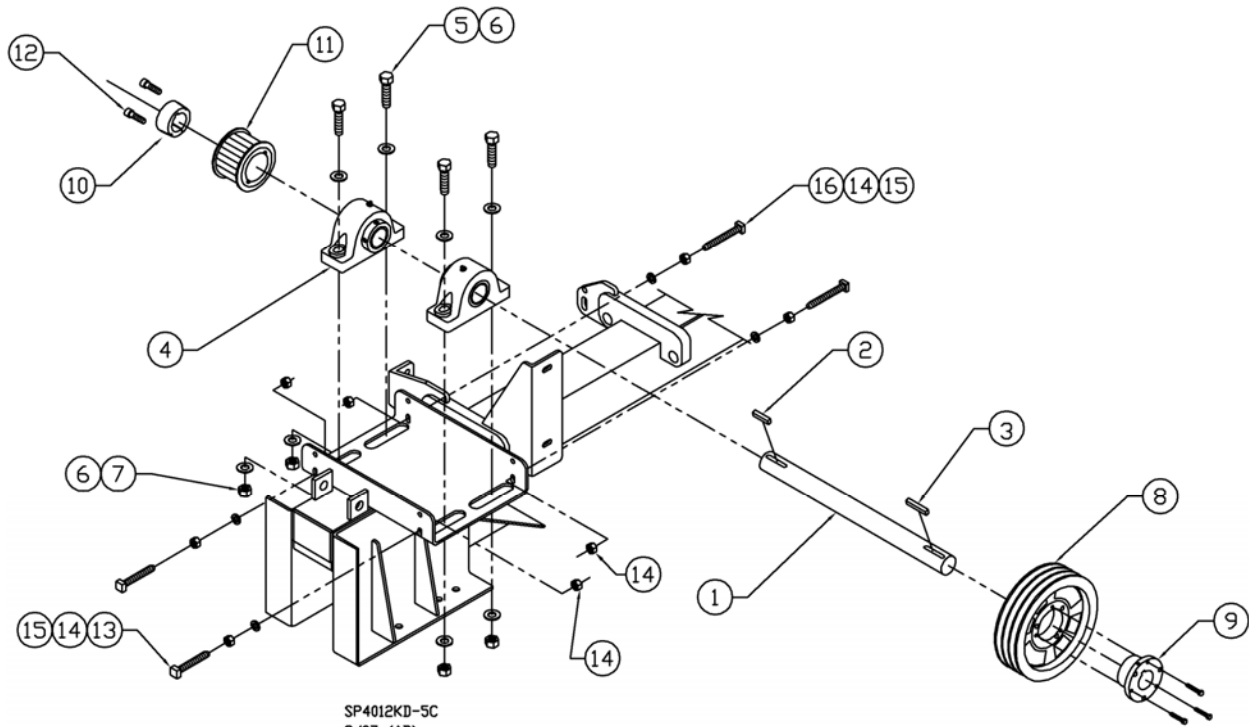

SP4012KD-5C
3/07 (AB)

POLY CHAIN® BELT ASSEMBLY

ITEM NO	PART NO	DESCRIPTION	QTY
1	2300249	Poly Chain® Belt Guard	1
2	0150117	3/8"-16 x 1" Carriage Bolt	4
3	0150303	3/8" Flat Washer	4
4	0150207	3/8"-16 Lock Nut	4
5	0250115A	Poly Chain® Sprocket	2
6	0250115F1	2012 Taper Lock Bushing – 1 11/16"	2
7		7/16"-14 x 1 1/2" SHCS	4
8	0400112	Poly Chain® Belt	1
9	2300225	Poly Chain® Bottom Guard	1
10	0150116	5/16"-18 x 1" HHCS	4
11	0150212	5/16"-18 Lock Nut	4
12	2300248	Poly Chain® Guard Cover	1
13	0150118	3/8"-16 x 1" HHCS	8
14	0150404	3/8" Lock Washer	8

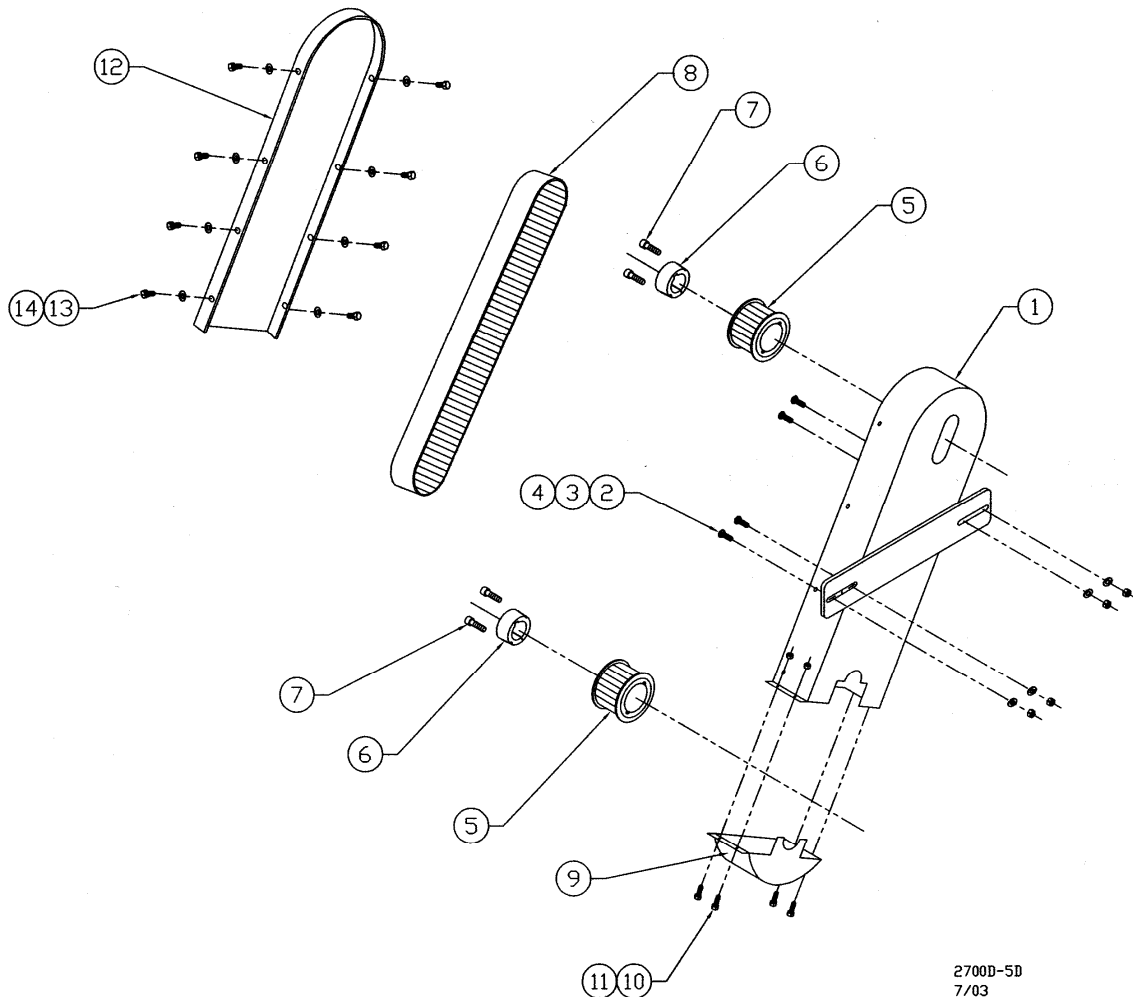

2700D-5D
 7/03

CUTTER WHEEL ASSEMBLY

ITEM NO	PART NO	DESCRIPTION	QTY
1	2700D184	Cutter Wheel Shaft – 1 11/16”	1
2	0500113	Bearing – 1 11/16”	2
3	0150125B	5/8”-11 x 2 3/4” HHCS	4
4	0150305	5/8” Flat Washer	8
5	0150216	5/8”-11 Lock Nut	4
6	A160T013	Key - 3/8” x 1 7/8”	1
7	A160T014	Key - 3/8” x 3”	1
8	0250122	Bushing – SKX – 1 11/16”	1
9	2300186	Cutter Wheel - 1”	1
10	2300188	Cutter Wheel Hub	1
11	2300183A	Spacer – 3 7/8” OD x 1 11/16” ID x 7/8”	1
12	2300183B	Spacer – 2 7/16” OD x 1 11/16” ID x 7/8”	1
13	0250115A	Poly Chain® Sprocket	1
14	0250115F1	2012 Taper Lock Bushing – 1 11/16”	1
15		7/16”-14 x 1 1/2” SHCS	2
16	2300197	Shaft Washer	1
17		1/2”-13 x 1 1/4” HHCS	1
18	0450106	Round Pocket - C/S	10
19	0450107	Round Pocket - Thd.	10
20	0450101	Tooth - Straight	2
21	0450102	Tooth - Right 45	9
22	0450103	Tooth - Left 45	9
23	0450109	5/8”-18 x 2 1/8” Tooth Bolt	20

CUTTER WHEEL ASSEMBLY

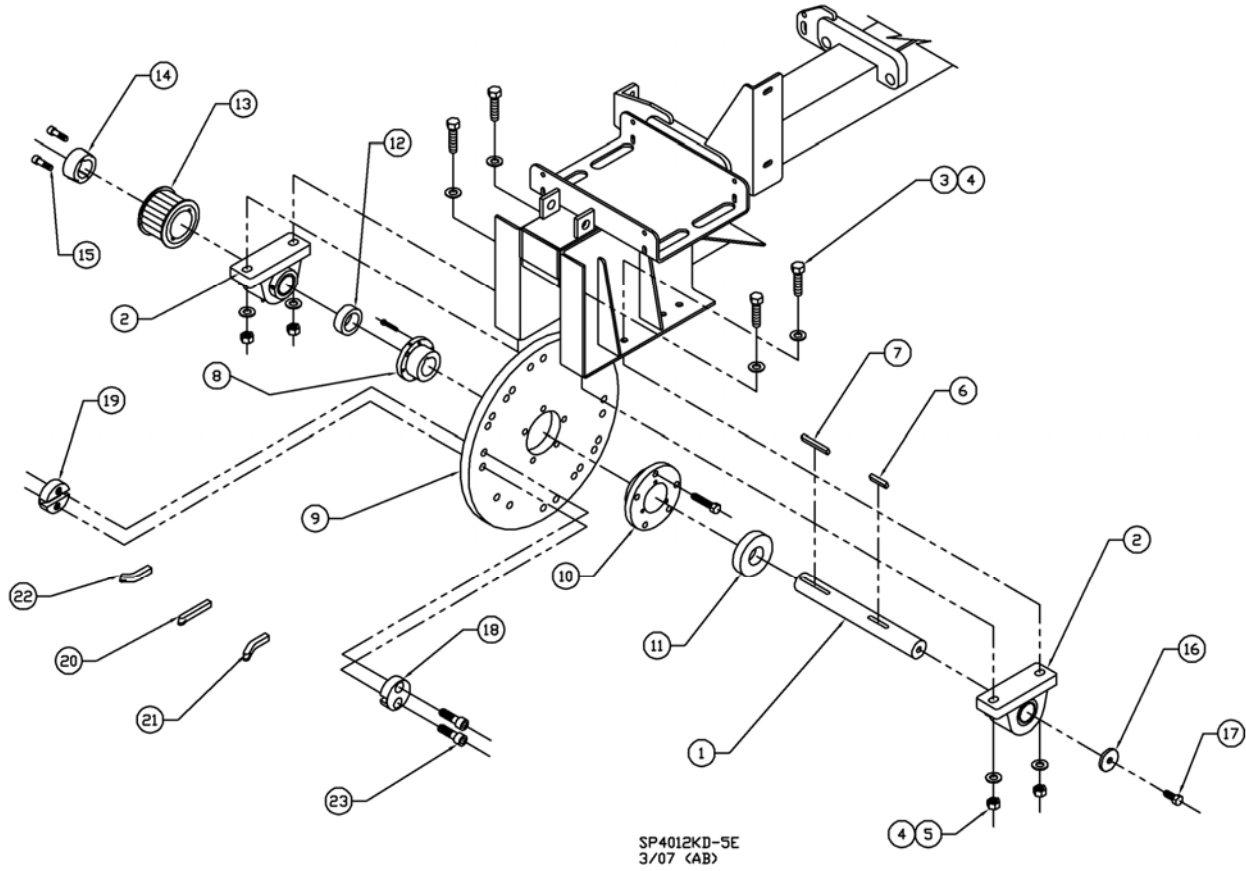

**CUTTER WHEEL ASSEMBLY
 (SANDVIK WHEEL OPTION)**

ITEM NO	PART NO	DESCRIPTION	QTY
1	2300184A	Cutter Wheel Shaft - 23/25 TL	1
2	0500112	Bearing - 1 7/16" - Link Belt	2
3	0150125B	5/8"-11 x 2 3/4" HHCS	4
4	0150305	5/8" Flat Washer	8
5	0150216	5/8"-11 Lock Nut	4
6	A160T013	Key - 3/8" x 1 7/8"	1
7	A160T014	Key - 3/8" x 3"	1
8	0250119	Bushing - 25 Engine -SH 1 7/16	1
9	14030053	Sandvik Cutter Wheel Weldment	1
10	2300188	Cutter Wheel Hub	1
11	2300183A	Spacer – 3 7/8" OD x 1 11/16" ID x 7/8"	1
12	2300183B	Spacer – 2 7/16" OD x 1 11/16" ID x 7/8"	1
13	0250115A	Poly Chain® Sprocket -	1
14	0250115F	2012 1 7/16" Taper Lock Bshn	1
15		7/16"-14 x 1 1/2" SHCS	2
16	2300197	Shaft Washer	1
17	30A-08	1/2" Lock Washer	1
18		1/2"-13 x 1 1/4" HHCS	1
19		Rect. Washer – 2 x 1 1/2 x 1/4 w/ 5/8" Hole	4
20	0450130	JP – Sandvik Plow Bolt Tooth	24
21	0450131	JP – Sandvik Short Plow Bolt Tooth	12
22	0450132	JP – Sandvik Plow Bolt Holder	24
23	0450125	Stover Lock Nut	36

**CUTTER WHEEL ASSEMBLY
(SANDVIK WHEEL OPTION)**

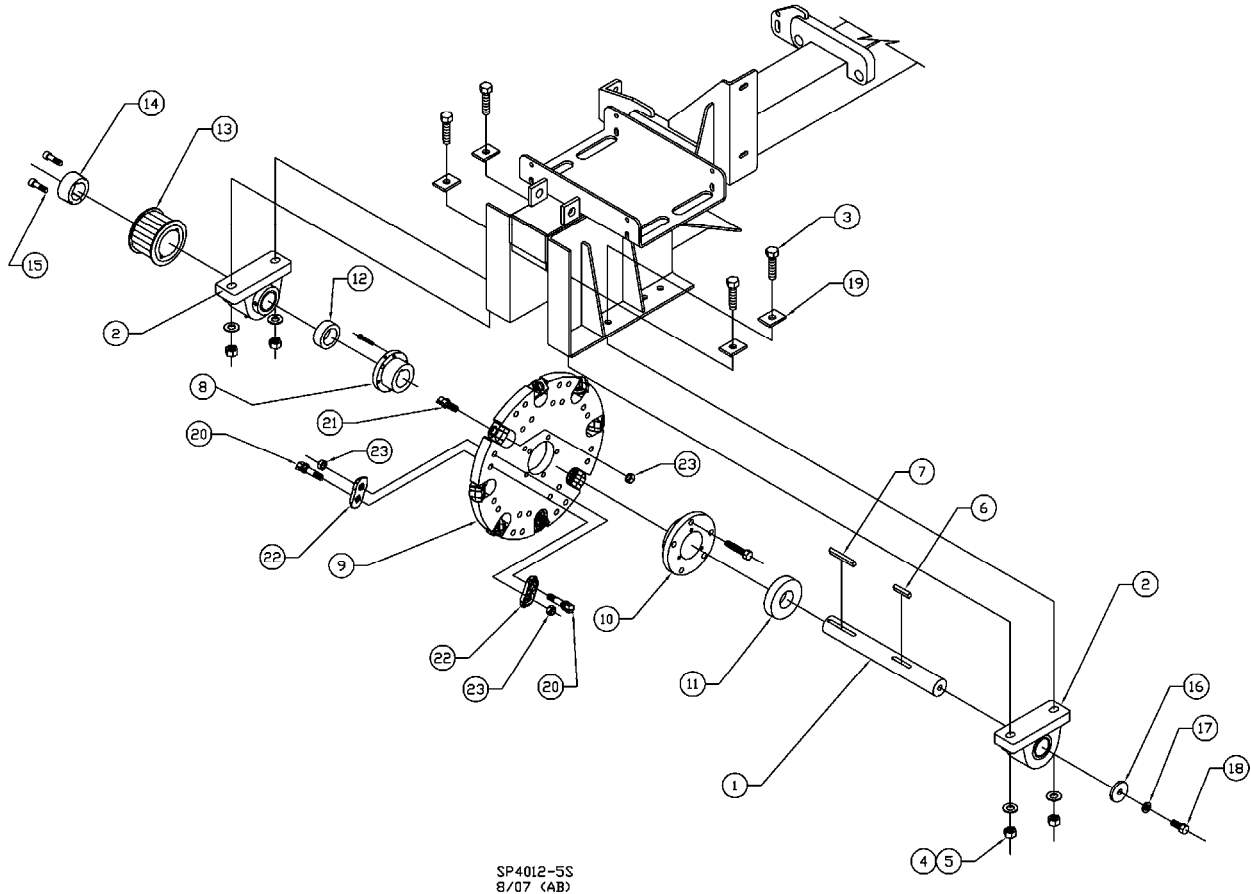

ITEM NO	PART NO	DESCRIPTION	QTY
1	2300134	2500 Deck Plate - R/H	1
2	2300135	2500 Deck Plate - L/H	1
3	0150119	3/8-16 x 3/4 Carriage Bolt	30
4	0150303	3/8 Flat Washer	34
5	0150207	3/8-16 Lock Nut	34
6	2300310	Front Rubber Chip Guard	1
7	2300311	Side Rubber Chip Guard	2
8	0150133H	3/4-10 X 6" Hex Head Bolt	1
9	2300218	Chip Guard Front Bracket	2
10	2300217	Chip Guard Side Bracket	2
11	2300193	Pan Guard - 2500	1
12	0150106B	1/2-13 x 1 1/4" Hex Cap Screw	2
13	0150206	1/2-13 Lock Nut	2
14	2300221	Boom Chip Guard Deck	1
15	0150117	3/8-16 x 1" Carriage Bolt	4
16	2300313	Front Boom Rubber Chip Guard	1
17	2300312	Side Boom Rubber Chip Guard	2
18	2300234	Chip Guard Bracket	4
19	2300261	Cutter Wheel Flap - 2500	1
20	0150211	3/4-10 Lock Nut	1
21	0150116	5/16-18 x 1" Hex Cap Screw	1
22	0150212	5/16-18 Lock Nut	1

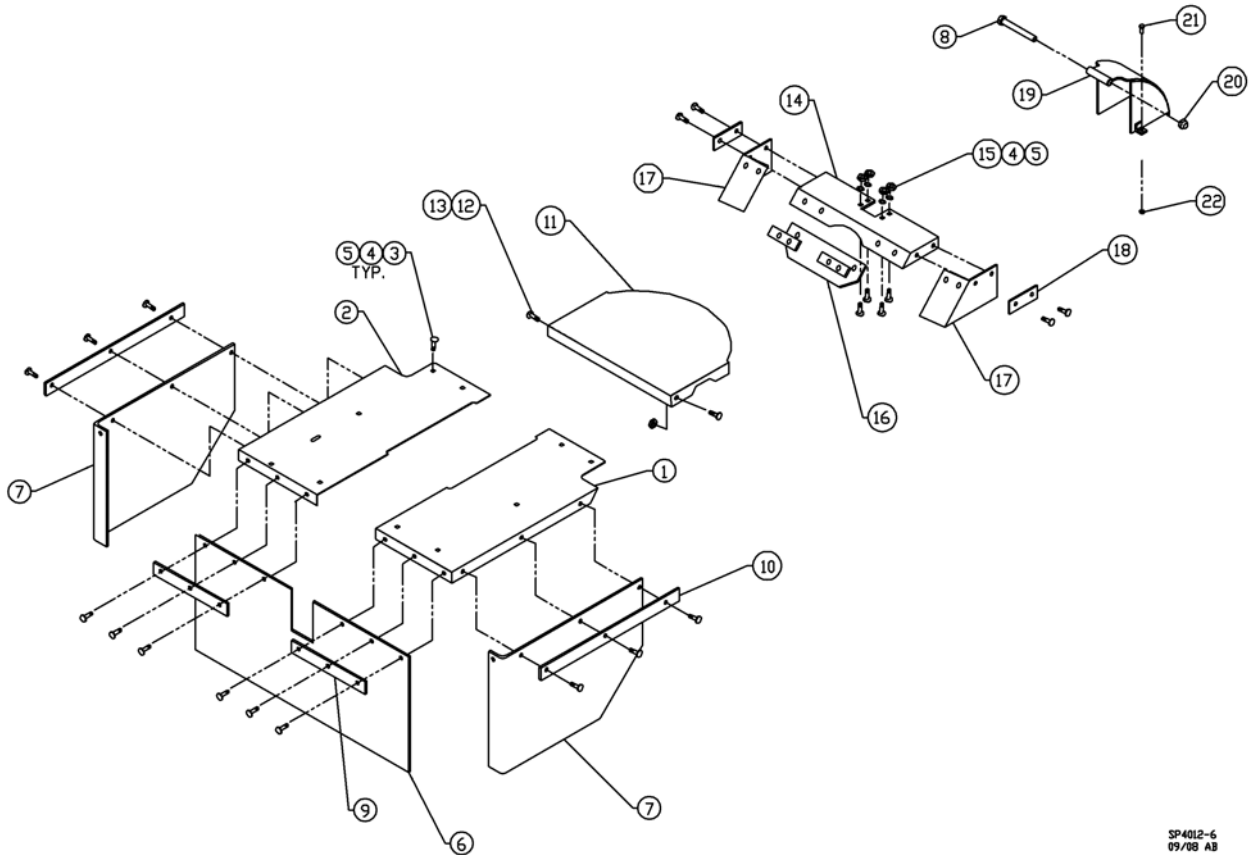

SP4012-6
09/08 AB

MODEL	TYPE	ENGINE	HP	FUEL	CUTTING DEPTH	CUTTING HEIGHT	CUT SWING	NO. TEETH	WHEEL DIA.	WHEEL THICKNESS	TONGUE EXTENSION	WEIGHT (lbs.)
900H	Walk-Behind	Honda	13	Gas	9"	21"	N/A	12	12.25"	.5"	N/A	220
SP2000	Walk-Behind	Kohler	27	Gas	24"	27"	N/A	16	19"	.5"	N/A	695
SP4012	Self-Propelled	Kohler	27	Gas	13"	34"	40" arc	20	21"	1"	30"	1,550
	Self-Propelled	Briggs-Vanguard	35	Gas	13"	34"	40" arc	20	21"	1"	30"	1,650
	Self-Propelled	Kubota	33	Diesel	13"	34"	40" arc	20	21"	1"	30"	1,650
SP7015	Self-Propelled	Deutz Turbo	60	Diesel	15"	43"	70" arc	32	26.5"	1"	N/A	3,500
SP7015TRX	Track-Mounted	Deutz Turbo	60	Diesel	15"	43"	70" arc	32	26.5"	1"	N/A	4,300
SP8018 TRX	Track-Mounted	Deutz Turbo	78	Diesel	18"	43"	80" arc	32	26.5"	1"	N/A	5,420
HURRICANE RS	Track-Mounted	John Deere Turbo	140	Diesel	25"	53"	360°	48	31"	1.5"	N/A	8,500
HURRICANE TRX	Track-Mounted	John Deere Turbo	140	Diesel	25"	72"	360°	64	36"	1.5"	N/A	12,000
	Track-Mounted	John Deere Turbo	175	Diesel	25"	72"	360°	64	36"	1.5"	N/A	12,000
	Track-Mounted	John Deere Turbo	250	Diesel	25"	72"	360°	64	36"	1.5"	N/A	12,000
3500D	Tow-Behind	Deutz Turbo	60	Diesel	15"	40"	80" arc	32	26.5"	1"	48"	2,900
7500	Tow-Behind	Deutz Turbo	78	Diesel	24"	46"	92" arc	48	31"	1.5"	60"	4,400

Call and ask about Carlton's line of Chippers or visit our website: www.stumpcutters.com

CARLTON—QUALITY PRODUCTS AND EXCEPTIONAL SERVICE



J.P. Carlton Company Div. DAF, Inc.
121 John Dodd Road
Spartanburg, South Carolina 29303
864-578-9335 • 800-243-9335 • FAX 864-578-0210

Carlton Owner's Manual
SP4012
Revised: 09/2008



OMNEX
TRUSTED WIRELESS

JP Carlton SP4012

Installation / Configuration Manual

**T151 Transmitter
R160 Receiver**

December 21, 2005

DM-R160-0190A

Revision 2

This page is intentionally left blank.

Table of Contents

System Overview	4
Features	4
T151 Dimensions and Controls	4
Installing the Receiver	5
Special Functions	6
Installation Considerations	6
Power the Transmitter	7
Test the Transmitter / Receiver Link	7
Download ID Code	8
Diagnostics—T151 Transmitter	10
Diagnostics—R160 Receiver	11
Trouble Shooting Guide	12
Parts & Accessories	16
Specifications	16
Warranty Information	16

NOTE: These instructions are intended only for installing and operating the remote control equipment described here. This is not a complete Operator's Manual. For complete operating instructions, please read the Operator's Manual appropriate for your particular machine.

Safety Precautions

READ ALL INSTRUCTIONS

CAUTION: Changes or modifications not expressly approved by the party responsible for compliance could void the user's authority to operate the equipment.

Failure to follow the SAFETY PRECAUTIONS may result in radio equipment failure and serious personal injury

Installation

PROVIDE A SAFETY CUTOFF SWITCH. If maintenance is required, the radio must be disconnected from power
USE PROPER WIRING. Loose or frayed wires can cause system failure, intermittent operation, machine damage, etc.
DO NOT INSTALL IN HOT AREAS. This apparatus can be damaged by heat in excess of 158° F (70° C)

Personal Safety

MAKE SURE MACHINERY AND SURROUNDING AREA IS CLEAR BEFORE OPERATING. Do not activate the remote system unless it is safe to do so.

TURN OFF THE RECEIVER POWER BEFORE WORKING ON MACHINERY. Always disconnect the remote system before doing any maintenance to prevent accidental operation of the machine

Care

KEEP DRY. Do not clean the transmitter / receiver under high pressure. If water or other liquids get inside the transmitter battery or receiver compartment, immediately dry the unit. Remove the case and let the unit air dry

CLEAN THE UNIT AFTER OPERATION. Remove any mud, dirt, concrete, etc. from the unit to prevent clogging of buttons, switches, etc. by using a damp cloth.

Maintenance / Welding

DISCONNECT THE RADIO RECEIVER BEFORE WELDING on this machine. Failure to disconnect will result in the destruction of the radio receiver.

System Overview

The **ORIGA T151 / R160** is a portable, long range, programmable radio remote control system. Designed as a compact and easy-to-use product, this member of the **ORIGA** family puts complete control of your crane where it's needed most, with the operator. It's robust, easy to install and has complete self-diagnostics. This system can be a simple cable replacement or add intelligence to make it a total crane control package. It's a radio, a PLC and a valve driver all in one.

The **ORIGA T151 / R160** system uses Frequency Hopping Spread Spectrum (FHSS) technology. FHSS devices concentrate their full power into a very narrow signal that randomly hops from frequency to frequency within a designated band. This transmission pattern, along with CRC-16 error-checking techniques, enables signals to overcome interference that commonly affects licensed radios.

The **R160 receiver** is designed to be powered from a 12VDC or 24VDC system. It features 19 solid state, high-side driver input / output controls and a reliable E-Stop control.

The **T151 transmitter** comes with 4 to 7 switches. It uses standard, long lasting AA batteries. Each T151 transmitter uses a unique ID code to ensure that no two systems will conflict at a job site.

Features

- FCC, ISC, CE approved
- License free
- 1200 foot range @ 900 MHz (900 ft. @ 2.4 GHz)
- Hand held / weatherproof / ergonomic
- Simple "wire-and-use" installation
- Resilient to impact and shock
- Available in both 900 MHz and 2.4 GHz
- Available with E-Stop for ensured operator safety
- Factory configurable for all custom applications.



R160 Receiver

T151 Transmitter

T151 Dimensions and Controls

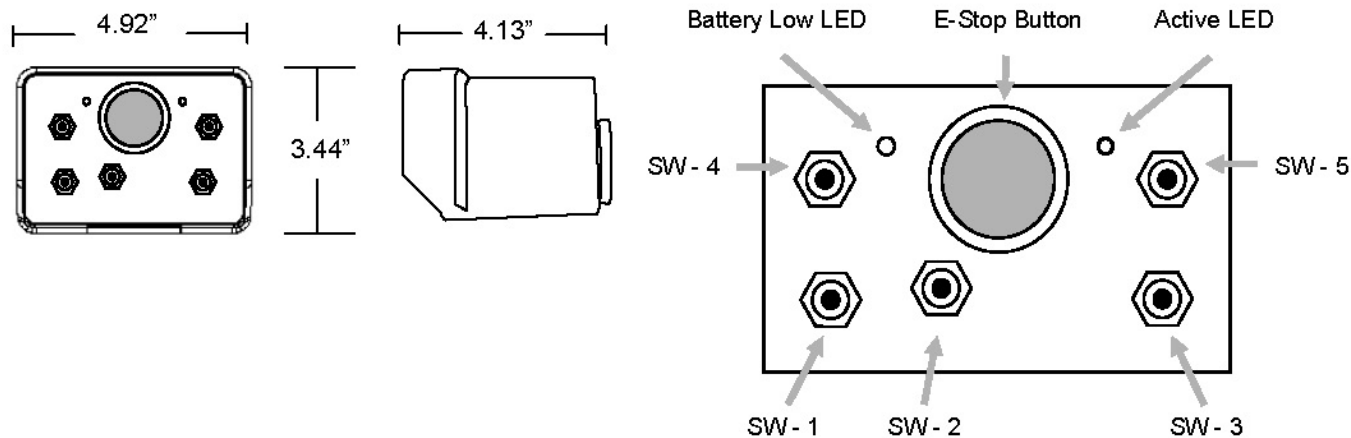

Installing the Receiver

Use the **Wiring Diagram** and the **Connector Diagram** below to connect the receiver pins directly to the appropriate contacts of the machine electronics. R160 Output Cables can be provided with every system to simplify the wiring process. The Wire Color column below only applies to the OMNEX Output Cable configuration. Tips on mounting, power connections and filtering are also provided under **Installation Considerations**.

Wiring Diagram

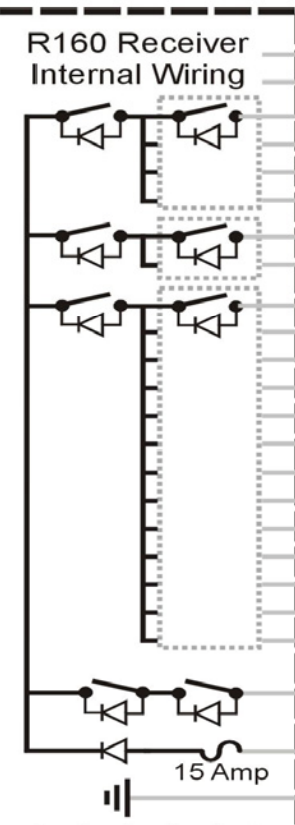

Pin-Output	Wire Colors	Functions	Notes
B7		Factory Configurable Only	
B8		Factory Configurable Only	
B12 - 19	Black/Red	Input / Output	
B11 - 18	White/Black	Input / Output	
B10 - 17	Blue/White	Input / Output	
A1 - 16	Blue/Black	Input / Output	
A2 - 15	Black/White	Input / Output	
A4 - 14	Green/Black	Input / Output	
B9 - 13	Red/White	Input / Output	
B6 - 12	Orange	Input / Output	
B5 - 11	White	Tongue Out	
B4 - 10	Green/Black/White	Tongue In	
B3 - 9	Green	Travel Reverse	
B2 - 8	Red/Black/White	Travel Forward	
B1 - 7	White/Red/Black	Gear Low	
A12 - 6	Orange/Red	Steer Left	
A10 - 5	Orange/Black	Steer Right	
A11 - 4	Blue/Red	Cutter Head Left	
A9 - 3	White/Red	Cutter Head Right	
A8 - 2	Red/Green	Cutter Head Down	
A7 - 1	Orange/Green	Cutter Head Up	
A5	Black/White/Red	Switches to Power with Link	
A6	Red	Power Input (+9V to 30VDC)	
A3	Black	Ground	

Outputs: 19 solid state, high-side driver outputs, 5A max. each, total combined current 15A
Inputs: All output pins can be factory configured as inputs.

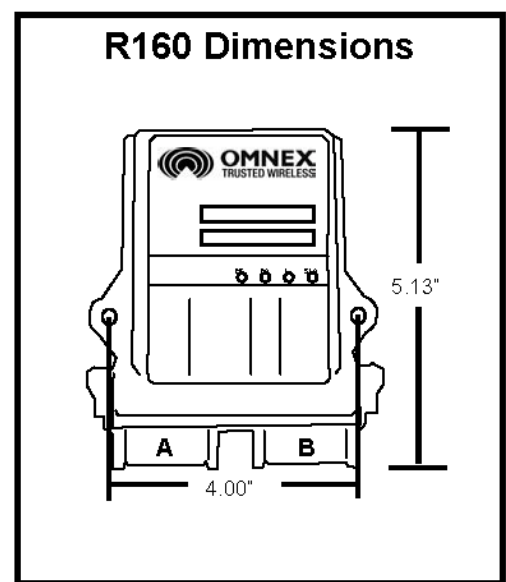
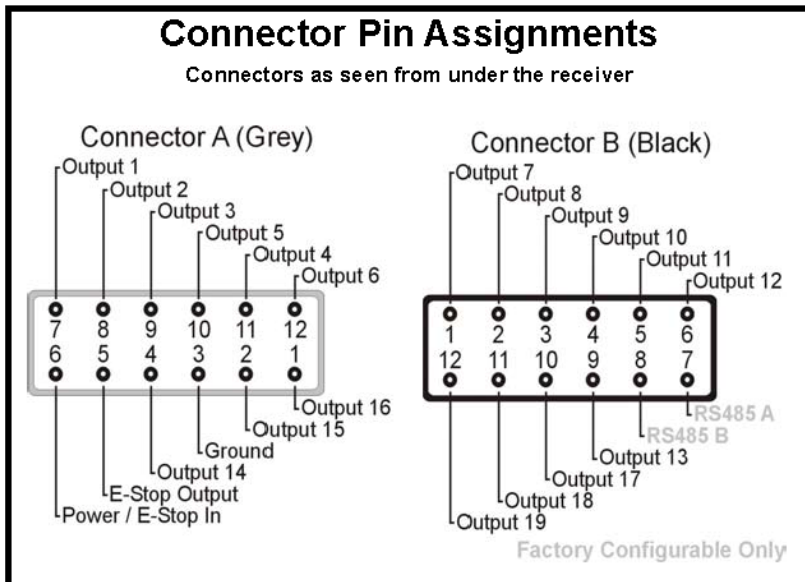

Special Functions

Note: The following functions are operational while the receiver has link with the transmitter. If link is not established, all receiver outputs will be unlatched (turned OFF).

Receiver outputs controlling CUTTER (Up, Down, Right, Left), STEER (Right, Left), TRAVEL (Forward, Reverse), and TONGUE functions (In, Out) turn ON momentarily while the corresponding transmitter switches are toggled.

The receiver output controlling the GEAR (Low) function is a latching output. Once ON, it will remain ON until GEAR (High) is pressed or loss of link occurs.

Pressing E-Stop will turn off the transmitter and immediately turn OFF (unlatch) all outputs.

Installation Considerations

Mounting and Installation

The receiver can be mounted by fastening two ¼" bolts through the two mounting holes in the unit's enclosure. When mounting, ensure that the receiver is oriented so that the text is reading right.

When selecting a mounting point for the receiver, it is recommended that the location require only a minimal length of wiring to connect it to the control panel, that it will be in a visible area where it has good exposure to the operator and that it is mounted on a surface that is protected from the weather and sustains minimal vibration. It is also recommended that the receiver have the best possible line of sight with the transmitter

Power Connections and Wiring

Whenever a power connection is made to an electronic device, it is a good practice to make both the Power (+) and Ground (-) connections directly to the Battery and avoid connecting the power from the charging side of existing wiring or making use of existing "ACC" or other peripheral connection points.

Make sure that wire of sufficient gauge and insulator type is used when connecting the outputs of the receiver to the control panel. Observe any component manufacturer's instructions and recommendations for proper integration of their product. This includes the power ratings and requirements of such components as relays, valves, solenoids, etc.

Be sure to test each of the outputs with a multi-meter prior to connecting the outputs to your end devices. This will ensure that each output has been programmed to operate in the manner required by each end device.

Filtering and Noise Suppression

Whenever a solenoid or electromagnetic switch is controlled by the receiver, it is a good practice to install a Diode across its terminals to ensure that surges and spikes do not continue back into the circuit. Appropriate 36V Bi-directional Diodes kits can be ordered under the OMNEX part number "AKIT-2492-01".

When the receiver has been installed, install batteries into the transmitter and turn it on as explained below.

1. Install Batteries

Remove the battery cover on the back of the transmitter using a slotted screwdriver and insert 4 "AA" alkaline batteries. Orientation of the batteries is embossed inside the battery housing.

NOTE: For operation at temperatures below -10°C to -40°C , lithium batteries are recommended. Low temperatures reduce battery performance for both alkaline and lithium types. Refer to the battery manufacturer's specifications for detailed information on low temperature performance.



T151 Battery Housing

2. Turn on the Transmitter

Refer to the **Light Legend** below for diagram details.

1. Press [E-Stop]

If the transmitter's (Active) light does not flash, check the battery orientation.

To turn off the transmitter, press the [E-Stop] button.

Follow these steps to ensure that there is a radio link between the transmitter and receiver.
Refer to the **Light Legend** below for diagram details



If the receiver's (Link) light does not flash GREEN, follow the steps under **Download ID Code** below.

The ORIGA system is now ready for use.

Download ID Code (Use in case of Link Test failure)

Follow these steps to download the transmitter's unique ID Code into the receiver. This will allow the receiver to establish a radio link with a specific transmitter or up to four transmitters (used individually). When downloading the first transmitters ID use step 4.1. and not 4.2.; for the remaining three transmitters use step 4.2. and not 4.1.

NOTE: It is necessary to download the ID Code when replacing either the transmitter or the receiver.

1. Opening the Receiver Case

The cap is held on by two plastic tabs at opposing sides, which can be unlatched as shown using a screwdriver. Once the cap is free, the R160 can slide open.

Use a small slotted screwdriver to press the Side Tabs inward.

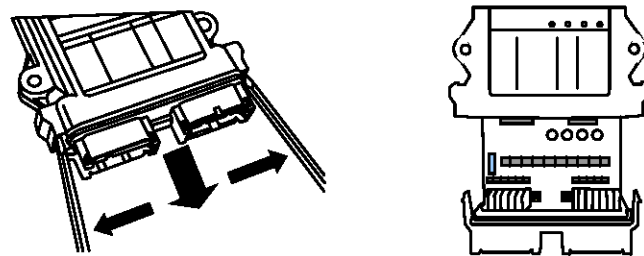

2. Prepare T151, Power R160

A. Press [E-Stop]

B. Twist clockwise & release [E-Stop]

C. Supply power to the receiver

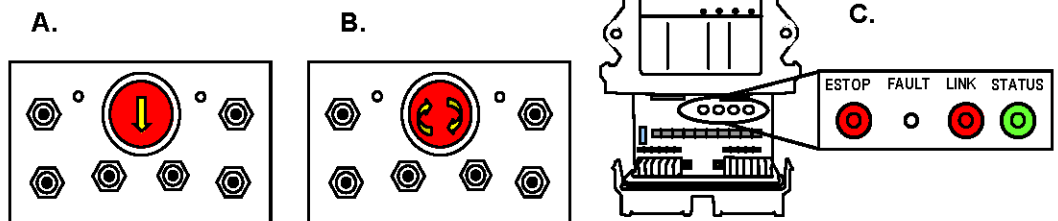

3. Power T151 into Configuration Mode

A. Hold [SW-5] switch UP

B. Press [E-Stop]

C. Twist clockwise & release [E-Stop]

D. Release [SW-5] Switch

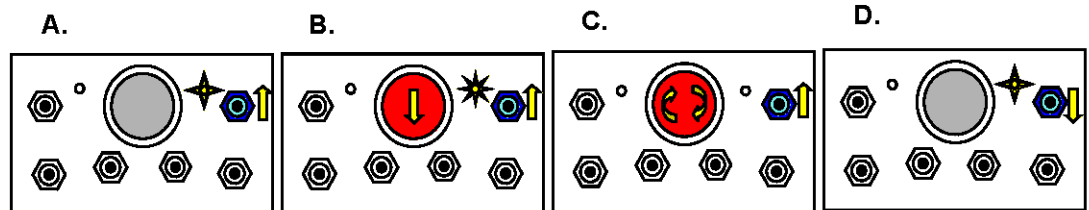

Download ID Code (Con't)

4.1. Put Receiver into Setup Mode for Primary ID

- A. Press & hold [Setup] button until (Status) light goes from slow flash to fast flash
- B. Release [Setup] button. (Status) light goes to solid GREEN, (Link) light turns off

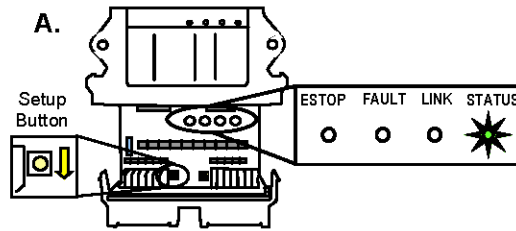

NOTE 1: Programming the Primary ID will clear all other ID's already programmed into the receiver.

NOTE 2: If left idle in Setup Mode for over 30 seconds, the receiver will time out. The (Link) light and (Status) light will flash RED rapidly. To return to Setup Mode, repeat step 4.

OR

4.2. Put Receiver into Setup Mode for Secondary ID's

- A. Press & hold [Setup] button until (Status) light goes from slow flash to fast flash to medium flash (approx. 10 Sec.)
- B. Release [Setup] button. (Status) light goes to solid GREEN, (Link) light turns off

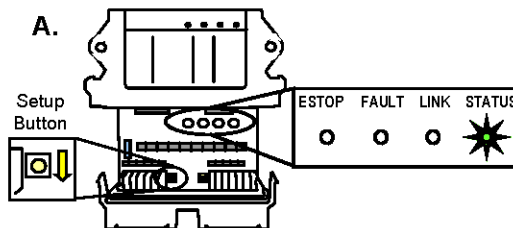

NOTE 1: The Receiver will hold up to 4 Transmitter ID's. When the 5th Transmitter ID is downloaded, it's ID will replace the ID of the least recently used transmitter (i.e. The receiver will retain the ID's of the three transmitters that have been most recently linked).

NOTE 2: If left idle in Setup Mode for over 30 seconds, the receiver will time out. The (Link) light and (Status) light will flash RED rapidly. To return to Setup Mode, repeat step 4.

5. Download ID Code

- A. Press [SW-5] switch UP
- B. (Link) light goes to GREEN. Once complete, (Link) light goes to RED as the transmitter turns off

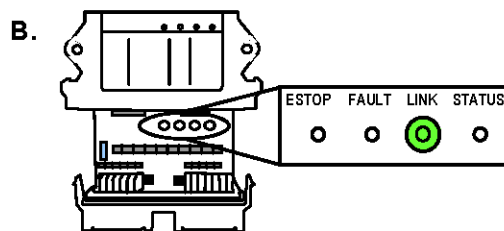
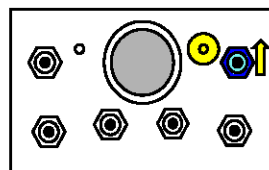

NOTE: When replacing the receiver cover, ensure the cover snaps completely into place to create a weather proof seal around the base of the receiver.

6. For multiple ID Downloading

- A. Repeat steps 3-5, **using step 4.2. instead of 4.1.** for all remaining Transmitters. Then check the link of all Transmitters one at a time by following the instructions on page 7, Test the Transmitter/Receiver Link.

Diagnosics—T151 Transmitter

	<p>Low battery. Unit will run approximately 10 hours after Battery light starts flashing.</p>
	<p>Flashing rapidly for 10 seconds indicates a transmitter failure.</p>
	<p>Normal Operation The Active light will flash several times per second, indicating that the transmitter is sending signals to the receiver. The Active light will remain on momentarily whenever a function changes</p>
	<p>On Power Up Release the E-Stop button within 10 seconds to power up the transmitter, or the unit will power down.</p>
	<p>Normal Operation The transmitter is in Download Mode.</p>
	<p>On Power Up Press and release the E-Stop button within 10 seconds to power up the transmitter, or the unit will power down.</p>
	<p>Stuck switch detected. Ensure that all switches are in a centered position. The transmitter will not power up when a function is ON.</p>
	<p>On Power Down Unit is still powered. Check for stuck switches, as the transmitter will not power down when a function is ON. Alternating flash means that the transmitter is in Calibration Mode.</p>

<p>Light Legend</p>	<p>Solid </p>	<p>Slow Flash </p>	<p>Fast Flash </p>	<p>Red Light </p>	<p>Green Light </p>	<p>Yellow Light </p>	<p>Alternating Red & Green Light </p>
----------------------------	---------------	--------------------	--------------------	-------------------	---------------------	----------------------	---



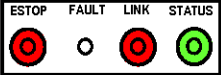
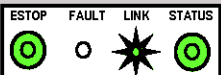
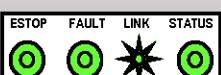
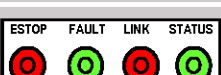

Diagnostics - R160 Receiver

Normal Operation

	Transmitter is OFF If the transmitter is off, the receiver is operating properly.
	Transmitter is ON When the transmitter is turned on, the Link light (fast flashing) and E-Stop (GREEN) indicates the receiver is operating properly
	Transmitter is in Operation When a function is activated on the transmitter, the Fault light will turn on GREEN. This indicates the receiver is operating properly
	Transmitter is OFF When a latched function is activated then the transmitter is turned off, the Fault light will stay on GREEN. If the system was intentionally designed this way, the receiver is operating properly, if not call for service.

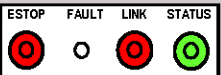
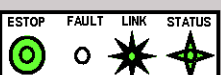
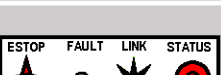
Trouble Indicators

Note: In some cases, the indicator lights will be different depending on whether the transmitter is on or off. Please note the transmitter status in the "Description" column for each case.

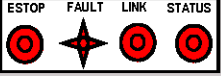
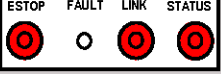
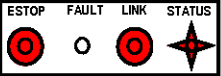
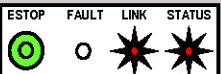
Indicator Lights	Description	Solution
	Transmitter is ON The reason is the transmitter is not communicating with the receiver.	Refer to Trouble Shooting Chart #3 for solutions
	Transmitter is ON A low battery condition has been detected.	To detect intermittent conditions caused by poor or corroded ground or power circuits, the GREEN light will continue to flash for 30 seconds after the condition has been removed.
	Transmitter is ON An internal fault with the E-Stop has been detected.	Inspect E-Stop wiring for short circuit. Disconnect E-Stop wire as close to the receiver output as possible. If the Status light changes to: <ul style="list-style-type: none"> • GREEN, a short occurs after disconnection point. • Stays flashing RED, send it in for service .
	Transmitter is ON A short to ground or excessive current draw on an output. It is most likely caused by a wiring fault.	Ensure transmitter is functioning properly, check status of each output connection: Press each function button and observe Fault Light. <ul style="list-style-type: none"> • If GREEN, everything is OK. • If RED, there is a short in that connection.
	Transmitter is ON The E-Stop output has been connected with one of the other outputs	Follow the wire and check for connections with other wires, disconnect to see if condition clears. If not, call for service.
	Transmitter is OFF A wiring short to the battery has been detected.	Refer to Trouble Shooting Chart #1 for solutions
	Transmitter is OFF The receiver has detected an internal fault.	Refer to Trouble Shooting Chart #1 for solutions
	Transmitter is OFF Blown fuse detected.	Refer to Page 8 for instructions on how to open the receiver case to access fuse. Check wiring for shorts or bare spots. If fuses continue to blow, call for service.
	Transmitter is ON A setup failure has occurred.	Either hold the Setup button for 5 seconds to return to Setup mode or cycle power to return to the normal operating mode.
	Transmitter is OFF The receiver is powered incorrectly.	Most likely cause of this condition is that an output wire or the E-Stop wire has been connected to the power supply while the power wire is disconnected from the power supply.

Light Legend	Solid	Slow Flash	Fast Flash	Red Light	Green Light	Yellow Light	Alternating Red & Green Light
							

Test the Receiver—R160

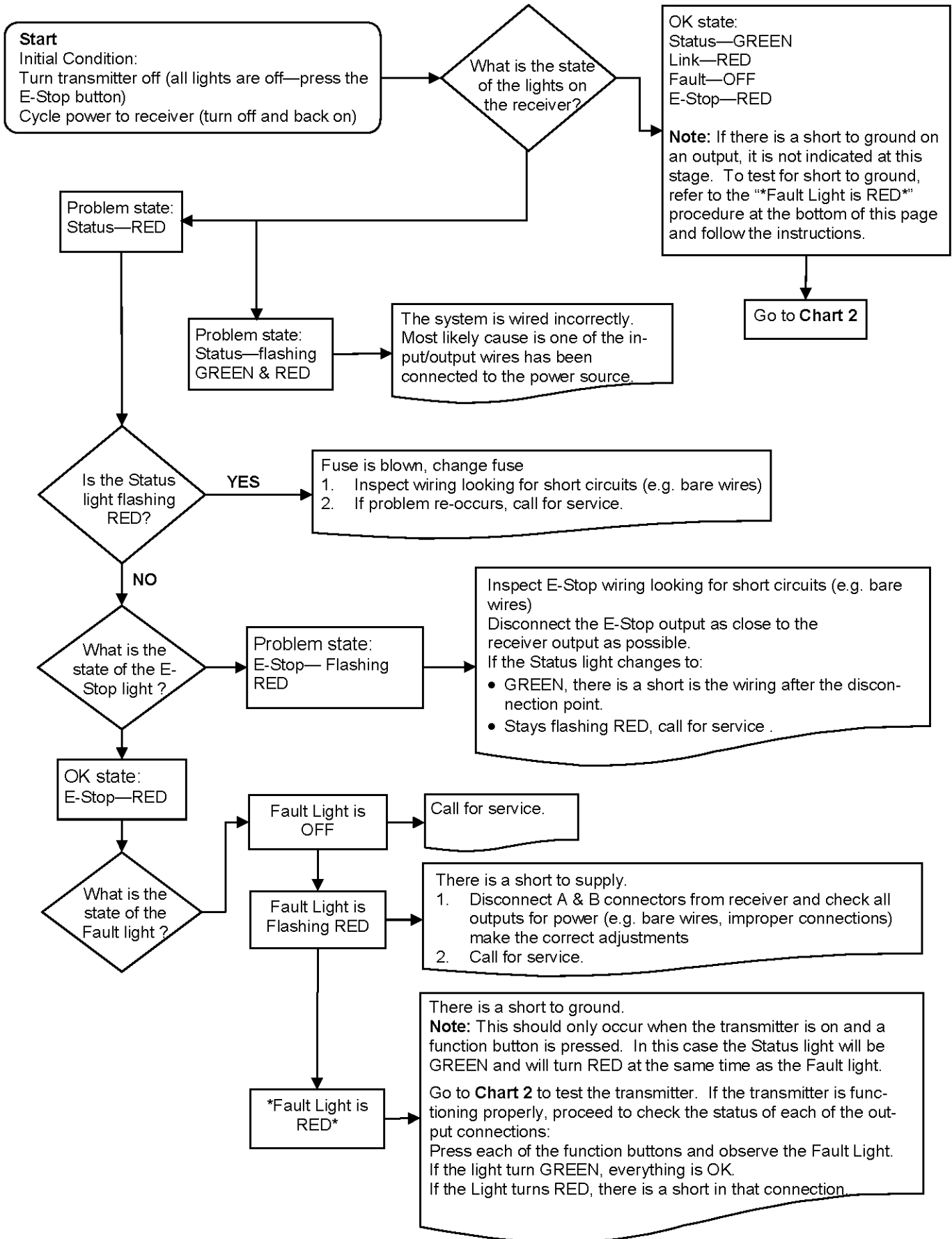

Test the Transmitter—T151

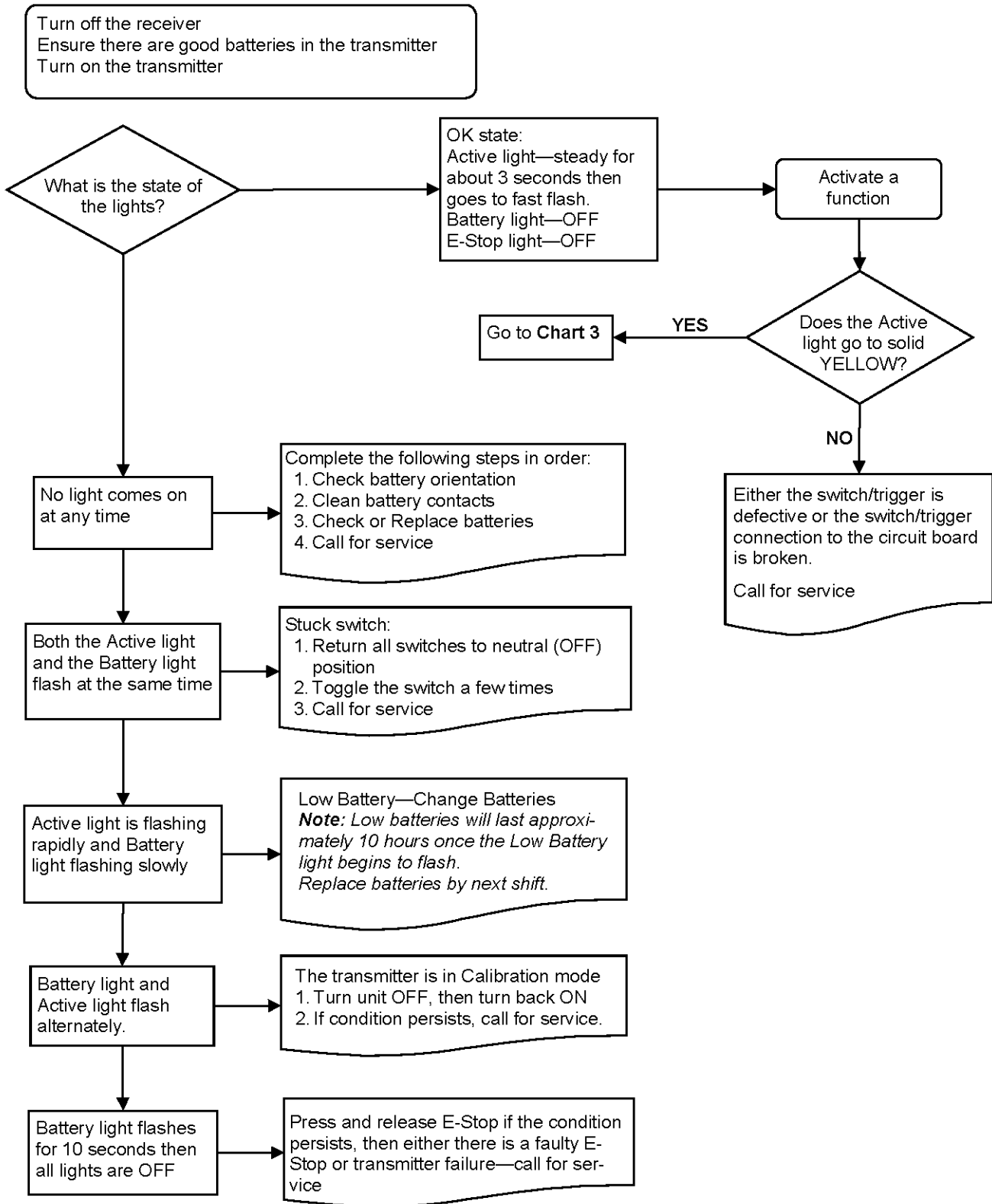

Testing the Transmitter / Receiver Communication

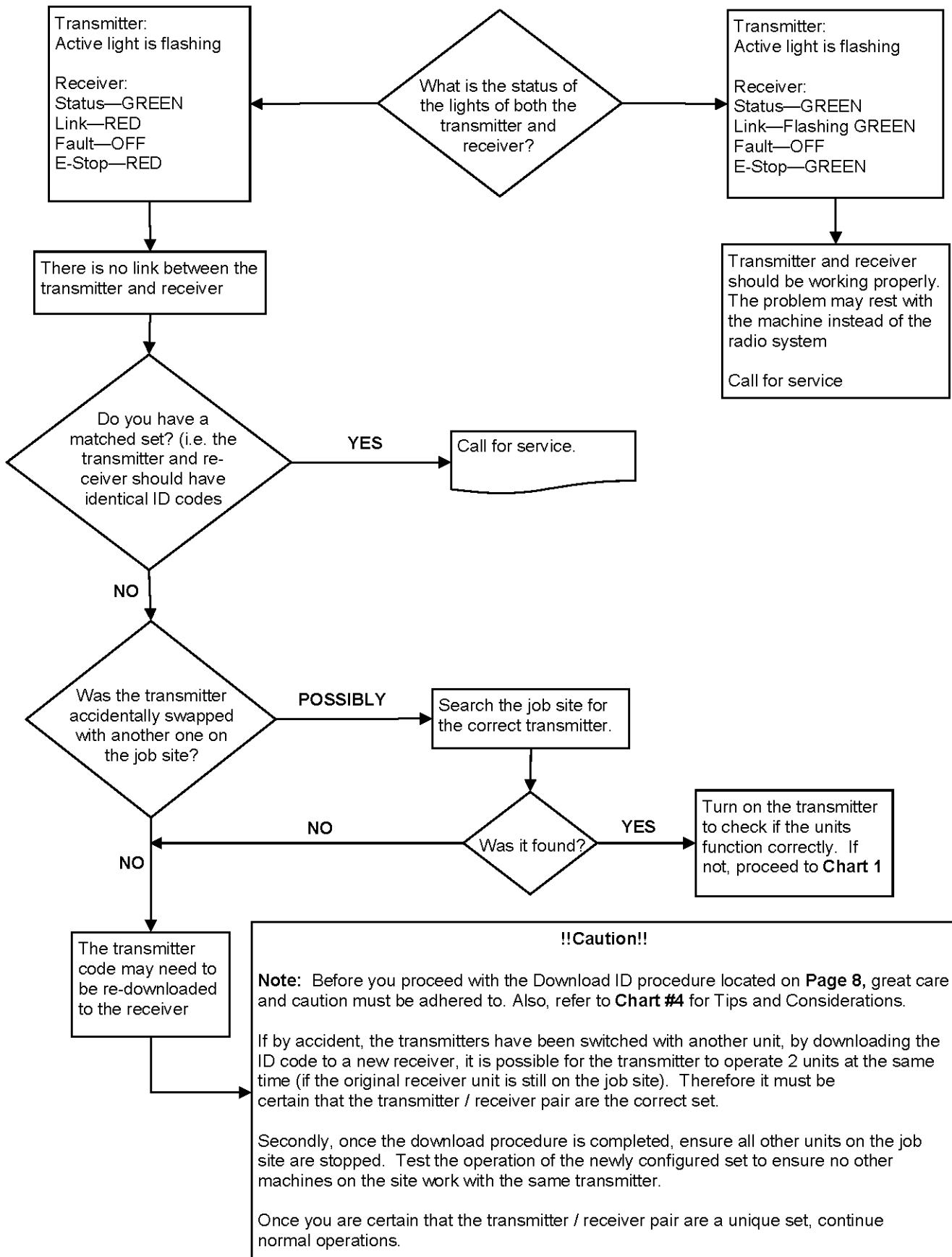

Considerations when Downloading the ID

Potential downloading issues

If testing of the receiver and transmitter both show the system as working (Chart 1 & 2), then the transmitter and receiver will both go into Download/Configuration mode.

Possible issues could arise during Step 4, the download phase of reprogramming. In this case there are 2 symptoms to look for:

1. The Link light on the receiver will not turn GREEN when the power switch is toggled on the transmitter to download
2. The receiver will “time out” indicating that it didn’t receive a signal from the transmitter within the 30 seconds from the time the receiver was put into Setup Mode.

If all indications appear normal during the download phase, test the link by turning on the transmitter (note: the transmitter shuts off after transmitting the ID code in Step 4)

1. If the Link light on the receiver doesn’t turn GREEN, the receiver didn’t receive all of the information that was sent from the transmitter.

Possible Solutions

1. Try the Downloading steps again
2. If this doesn’t correct the problem, send both the transmitter and receiver in for service.

Note: you could try to determine whether the fault lies with the transmitter or receiver by completing the downloading procedure with a different transmitter. If this step works, then the fault lies with the original transmitter. If not, the fault may lie with the receiver.

!!Caution!!

Note: Before attempting downloading with another transmitter, understand that reprogramming the receiver with another transmitter, could result in two receivers on the job site responding to the one transmitter. If the original transmitter was sent in for repair, Disconnect the receiver (disconnect connector A) to continue using the machine without remote capability and without fear of inadvertently operating the machine with the other transmitter.

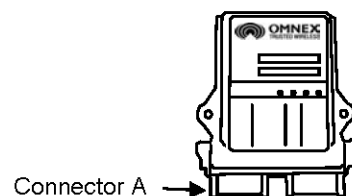

Reprogramming Tips:

1. Use a pointy instrument to depress the Setup button on the receiver (i.e. a pen) as the button is relatively small
2. Follow each step as laid out in the procedure
3. Never lay the receiver circuit board down on anything metallic (there are contact points on the back which could contact the metal and damage the receiver)

Parts & Accessories

Part	Part Number	Description
Batteries	B0010	4 x AA alkaline
R160 Output Cables	ACAB-2493-01	Generic Output Cable- see illustration
Toggle Switch	AKIT-1504-04	Honeywell 1TL1-7
E-Stop Button	AKIT-1821-02	RAFIX16, 25mm, C&K 1.30074.2810300 See illustration
Magnet Back	AKIT-2498-02	see illustration
Bipolar Diode Kit	AKIT-2492-01	36V, Bi-directional, Motorols P6KE36CA
Fuse	F0039	Bussman ATC-15
Socket Connectors	J0418	Grey, 12-pin, Deutsch DTM06-12SA
Socket Connectors	J0419	Black, 12-pin, Deutsch DTM06-12SB
	J0420	12 pos., Deutsch WM12S
Pin	J0417	Female, Size 20, Deutsch 0462-201-20141
Sealing Plug	J0421	Size 20, Deutsch 0413-204-2005
R160 Connector Kit	AKIT-2337-01	Includes Deutsch socket connectors, wedges, pins and sealing plugs.



R160 Output Cable



E-Stop



Magnet Back

Specifications

	R160 Receiver	T151 Transmitter
Size	5.1" x 4.7" x 1.4" (130mm x 119mm x 36mm)	3.44" x 4.9" x 4.13" (87mm x 124mm x 105mm)
Weight	0.65lbs (0.295kg)	1.8lbs (0.817kg)
Construction	High impact plastic, weatherproof	High impact, low temperature plastic, weatherproof
Input Power	+9V to 30VDC	4AA alkaline batteries
Battery Life	N/A	>120 hours (continuous use)
Operating Temperature Range	-40F to 158F (-40C to 70C)	-40F to 158F (-40C to 70C)
Outputs	3A (max) each (sourcing), 10A (max) each (combined)	N/A
Antenna	Internal	Internal
Approvals	USA- FCC part 15.247 Canada- ISC RSS 2210 Europe- EN 440 Australia- C-Tick	

FCC Rules and Compliance

This device complies with Part 15 of the FCC Rules. Operation is subject to the following two conditions: (1) This device may not cause harmful interference, and (2) this device must accept any interference received, including interference that may cause undesired operation.

FCC Part 15.247
ISC RSS 210

Warranty

OMNEX Control Systems Inc. warrants to the original purchaser that the OMNEX products are free from defects in materials and workmanship under normal use and service for a period of ONE YEAR, parts (EXCLUDING: SWITCHES, CRYSTALS, OR PARTS SUBJECT TO UNAUTHORIZED REPAIR OR MODIFICATION) and labor from the date of delivery as evidenced by a copy of the receipt. OMNEX's entire liability and your exclusive remedy shall be, at OMNEX's option, either the (a) repair or (b) replacement of the OMNEX product which is returned within the warranty period to OMNEX freight collect by the OMNEX APPROVED carrier with a copy of the purchase receipt and with the return authorization of OMNEX. If failure has resulted from accident, abuse or misapplication, OMNEX shall have no responsibility to repair or replace the product under warranty. In no event shall OMNEX be responsible for incidental or consequential damage caused by defects in its products, whether such damage occurs or is discovered before or after replacement or repair and whether or not such damage is caused by the negligence of OMNEX Control Systems Inc.

OMNEX Control Systems Inc.