



Model Hurricane *RS*

Model Hurricane *TRX*

Machine Serial # _____
Engine Model & Spec # _____
Engine Serial # _____
HPTO/Clutch Model & Spec # _____
Clutch Serial # _____
Purchase Date _____
Dealer _____

Carlton

J.P. Carlton Company
Div. D.A.F. Inc.
121 John Dodd Road
Spartanburg, SC 29303
Ph. (864) 578-9335
Fax (864) 578-0210
www.stumpcutters.com

CALIFORNIA

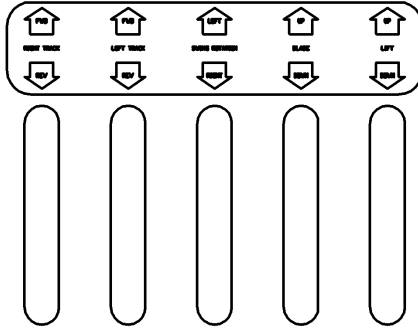

Proposition 65 Warning

Diesel engine exhaust and some of its constituents are known to the State of California to cause cancer, birth defects, and other reproduction harm.

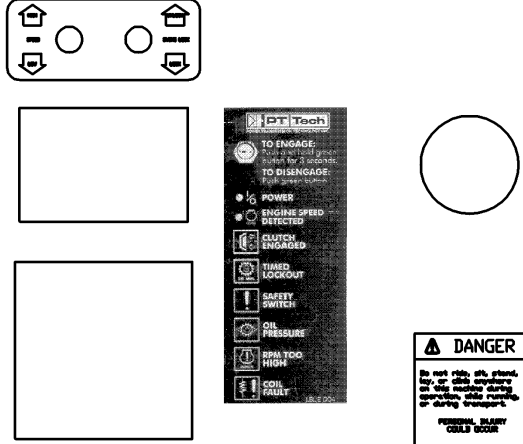

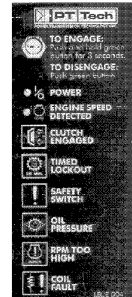



<p>⚠ DANGER</p> <p>Do not raise, tilt, extend, lay, or shift any part of the machine during operation, while running, or during transport.</p> <p>PERSONAL INJURY OR DEATH POSSIBLE</p>	<p>⚠ DANGER</p> <p>Do not raise, position, or tilt machine and extend while cutter head is engaged. Do not transport machine with angle leveling.</p> <p>PERSONAL INJURY OR DEATH POSSIBLE</p>
<p>⚠ DANGER</p> <p></p> <p>No inexperienced person may operate machine. Inexperience may cause injury.</p> <p>Read operation manual, engine manual & all safety alerts on machine before operation.</p>	<p>⚠ WARNING</p> <p></p> <p>Wear eye and ear protection when you are in operating position.</p>
<p>⚠ WARNING</p> <p>If this equipment is "turned over", you will cause engine damage, hydraulic damage, and possible personal injury.</p>	<p>⚠ WARNING</p> <p></p> <p>This machine may be over-tilted. Always use caution when operating on uneven surfaces.</p>

DAILY CHECKLIST

- Check engine oil. Check with engine running level. Add recommended oil. Use engine oil recommended.
- Check air filter & groundwork. Inspect dry air cleaner. **DO NOT RUN ON TOP OF GRASS. REPLACE WITH INSTRUCTIONS. RECOMMENDED AIR FILTER SIZE.**
- Check fuel filter for debris or water.
- Replenish fuel tank with fresh fuel.
- Check condition and tightness of belts.
- Check for any loose, broken or missing cutter teeth and protectors.
- Inspect belts, hydraulic fittings, air lines, hoses, boom, and equipment for tightness, wear, or leakage. Replace if necessary.
- Check hydraulic oil level. A slight sag is located on the tank. Add if required.
- Grease cutter shaft and joint shaft bearings before and after operation to keep dirt and moisture out. Pump with clean grease is used.
- Check condition and tension of tracks.



Carlton X
PROFESSIONAL
TREE EQUIPMENT

⚠ DANGER

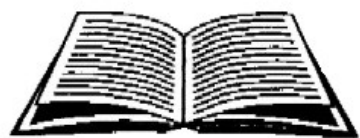

No inexperienced person may operate machine. Inexperience may cause injury.

Read operation manual.

⚠ WARNING



Loud noise. Flying debris.

Hearing and eye protection must be worn while in operation.

⚠ WARNING



This machine may tip over sideways if operated on non-level surface.

Always use caution when operating on non-level surface.

⚠ WARNING

IF THIS EQUIPMENT IS TURNED OVER, YOU WILL CAUSE ENGINE DAMAGE, HYDRAULIC DAMAGE, AND POSSIBLE PERSONAL INJURY.

JPC38

⚠ DANGER

Do not move, position, or transport this machine while cutterwheel is engaged.
Do not transport machine with engine running.

PERSONAL INJURY OR PROPERTY DAMAGE COULD OCCUR.

⚠ DANGER

Do not ride, sit, stand, lay, or climb anywhere on this machine during operation, while running, or during transport.

PERSONAL INJURY COULD OCCUR

⚠ DANGER



Stay clear while machine is in operation.

Cutter wheel will cause severe injury or death.

JPC27

⚠ DANGER



Pinch Points

Keep body parts away while in operation.

JPC09

WARNING

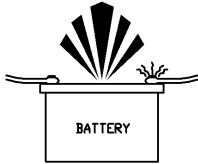

**USE CAUTION IN
EXTREME COLD!
FROZEN BATTERY
WILL EXPLODE!**

NEVER JUMP START A BATTERY IN FREEZING TEMPERATURES. INSPECT BATTERY FOR SIGNS OF FROST BEFORE STARTING IN EXTREME COLD. MOVE EQUIPMENT TO A HEATED, WELL VENTILATED AREA TO ALLOW BATTERY TO THAW BUT NOT NEAR FIRE, SPARKS, OR OTHER SOURCES OF IGNITION.

BATTERY FUMES ARE EXPLOSIVE. NEVER USE JUMPER CABLES OR RECHARGE BATTERY UNLESS IN AN OPEN OR WELL VENTILATED AREA AND AWAY FROM ALL SOURCES OF IGNITION. BATTERY ACID CAN CAUSE SEVERE BURNS. KEEP AWAY FROM EYES, SKIN, AND CLOTHING.

ALWAYS REMOVE BATTERY BEFORE WELDING ON EQUIPMENT. FOLLOW PROCEDURES FOR WELDING AND GROUNDING BEFORE STARTING TO WELD ON THIS MACHINE OR EQUIPMENT DAMAGE AND POSSIBLY SEVERE PERSONAL INJURY WILL OCCUR.

0700314

WARNING



KEEP AWAY FROM PRESSURIZED LEAKS

Pressurized leaks are not always visible. Check for pressurized leaks using cardboard or wood. Never use a finger, hand or other body part to check for leaks.

Injuries from pressurized leaks penetrating the skin will lead to serious health problems or death. CONSULT A PHYSICIAN IMMEDIATELY IF PENETRATION OCCURS, SURGICAL REMOVAL REQUIRED.

Release pressure from line before loosening, removing or replacing any hydraulic hoses or equipment.

0700317

WARNING

**SEVERE ENGINE DAMAGE
WILL OCCUR IF THIS
ENGINE IS OPERATED AT
AN ANGLE GREATER
THAN 25°**

PROPER ENGINE OIL LEVEL
MUST BE MAINTAINED TO
ACHIEVE MAXIMUM ANGLE OF
OPERATION OF 25°
(SEE ENGINE OWNER'S MANUAL
FOR PROPER OIL LEVEL)

0700075A

WARNING



FLAMMABLE FUEL

THIS MACHINE USES DIESEL FUEL AND HYDRAULIC OIL.

NEVER FILL TANK WHILE ENGINE IS HOT, RUNNING, OR IN A CONFINED AREA. DANGER OF FIRE OR EXPLOSION EXIST.

LEAVE ROOM IN THE TANK FOR EXPANSION FROM HEAT - NEVER FILL TANK COMPLETELY FULL.

KEEP MACHINE AWAY FROM FIRE, SPARKS, AND OTHER SOURCES OF IGNITION DURING USE AND STORAGE.

NEVER PUT MACHINE IN STORAGE WITH FUEL IN THE TANK.

ALWAYS STORE FUEL IN APPROVED (RED) CONTAINERS AND AWAY FROM SOURCES OF IGNITION.

0700316

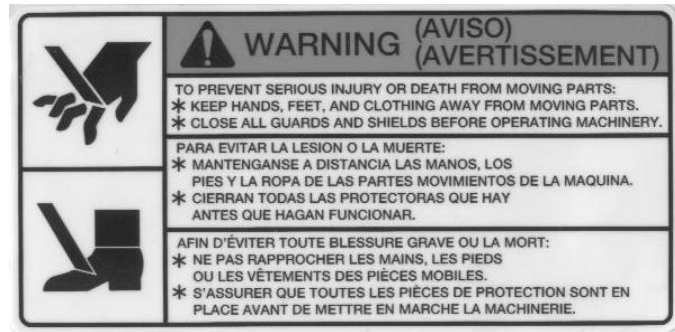

NOTICE

DECALS SHOULD BE PROPERLY MAINTAINED AND REPLACED. IT IS THE DUTY OF THE OWNER OF THIS EQUIPMENT TO KEEP DECALS IN GOOD CONDITION.

REPLACEMENT DECALS MAY BE PURCHASED FROM
J. P. CARLTON CO.

0700309

NOTICE

SERVICING BELTS AND BEARINGS

ALWAYS TURN OFF ENGINE AND REMOVE KEY BEFORE SERVICING! ALLOW ALL PARTS TO COME TO A COMPLETE STOP AND COOL BEFORE TOUCHING!

- New belts stretch and get loose. After 2 hours of operation, check tension and tighten belts.
- Check tension and retighten every 4 hours of operation until tension stays consistent.
- See manual for instruction and proper tension.
- Thereafter, check belt tension every month until belts need replacing.

AT LEAST ONCE A MONTH:

- CHECK AND TIGHTEN BOLTS AND LOCK SETSCREWS ON ALL BEARINGS.
- CHECK AND TIGHTEN SCREWS ON ALL BELT PULLEY BUSHINGS.

REFER TO MAINTENANCE SECTION

0700311



CAUTION

DO NOT OVER-TENSION TRACKS!!

TOO MUCH TRACK TENSION CAN CAUSE TRACK DAMAGE, BEARING DAMAGE, AND/OR FRAME DAMAGE.

THE CORRECT SAG DISTANCE BETWEEN THE TRACK AND THE ROLLER IS 1", MEASURED AT THE CENTER ROLLER. SEE PICTURED ILLUSTRATION IN OWNERS' MANUAL MACHINE MAINTENANCE SECTION FOR TRACK TENSIONING.

JPC070001_A

NOTICE

IMPORTANT MAINTENANCE

- REPLENISH RADIATOR COOLANT DAILY WHEN ENGINE IS OFF AND COLD. KEEPING THE ENGINE COOL AIDES IN LONG ENGINE LIFE. READ AND FOLLOW ENGINE MANUAL FOR COOLANT TYPE AND OTHER ADDITIVES.
- CLEAN ENGINE COOLING SYSTEM REGULARLY. (SUCH AS COOLING FANS, AIR COOLED ENGINE SHROUD, AND FILTER SCREENS, ETC.)
- BLOCKED FINS WILL KEEP RADIATOR FROM COOLING ENGINE SUFFICIENTLY. PRESSURIZED WATER SHOULD BE USED ONCE OR TWICE DAILY TO CLEAN RADIATOR FINS COMPLETELY. ALL DEBRIS MUST BE REMOVED FROM FINS. USING AIR PRESSURE WILL NOT CLEAN COMPLETELY.

ENGINE WILL OVERHEAT AND FAILURE WILL OCCUR IF RADIATOR AND COOLING EQUIPMENT ARE NOT MAINTAINED OR SERVICED CORRECTLY OR IF NEGLECTED.

0700328



STUMP GRINDER LIMITED WARRANTY

J.P. Carlton Co. Inc., hereafter referred to as the "Manufacturer", warrants each new Carlton Grinder to be free of defects in workmanship and material for a period of one year.

This warranty takes effect upon delivery to the original retail purchaser. The manufacturer, at its option, will replace or repair, at a point designated by the manufacturer, any parts which appear to have been defective in material or workmanship. The manufacturer is not responsible for consequential damages.

This warranty will not apply if the grinder is not operated in a manner recommended by the manufacturer. The following examples would void warranty:

1. The grinder has been abused.
2. The machine is involved in or damaged by an accident.
3. Repairs or attempted repairs were made without prior written authorization.
4. Including but not limited to repairs made due to normal wear.

The owner is responsible for all regular maintenance as explained in the operators' manual. Neglect in regular maintenance or failure to replace normal wear items such as teeth, pockets, lubrication oils, filters, belts, bearings, etc. may void warranty.

This warranty is expressly in lieu of any other warranties, expressed or implied, including any implied warranty or merchantability of fitness for a particular purpose and of any non-contractual liabilities including product liabilities based upon negligence or strict liability. J.P. Carlton Co. Inc. will not be liable for consequential damages resulting from breach of warranty.

IT IS NECESSARY TO RETURN THE WARRANTY VALIDATION FORM AND NOTIFY J.P. CARLTON CO. INC. IN WRITING WITHIN TEN (10) DAYS FROM DELIVERY DATE TO VALIDATE THIS WARRANTY.

NOTE: This warranty applies only to new and unused equipment or parts thereof manufactured by J.P. Carlton Co. Inc. ANY MACHINES USED FOR LEASE OR RENTAL - WARRANTY IS LIMITED TO 90 DAYS FROM FIRST DAY OF INITIAL SERVICE.

NOTICE: All power units and associated components are NOT warranted by J.P. Carlton Co. Inc. or their dealers. It is the customers' responsibility to return machine to the local engine distributor.

INFORMATION PHONE NUMBERS TO FIND YOUR LOCAL ENGINE & PARTS SERVICE CENTERS:

- Honda 1-770-497-6400 (GA-Eastern Time Zone)
- Kohler Engines..... 1-800-544-2444 (Toll Free)
- Briggs & Stratton Engines..... 1-800-233-3723 (Toll Free)
- Lombardini 1-770-623-3554 (GA-Eastern Time Zone)
- Deutz Engines..... 1-800-241-9886 (Toll Free)
- John Deere Engines 1-800-533-6446 (Toll Free)
- Caterpillar 1-877-636-7658 (Toll Free)
- Kubota 1-847-955-2500 (IL-Central Time Zone)
- Kawasaki Engines..... 1-616-949-6500 (MI-Eastern Time Zone)
- Wisconsin Engines 1-800-932-2858 (Toll Free)
- Onan Engine 1-800-888-6626 (Toll Free)

In order to process any warranty claims, it is the owners' responsibility to report claims promptly to us or our authorized dealer from whom the equipment was purchased. It is necessary to include the following information on any and all request for warranty:

- | | |
|-------------------------------|----------------------------------|
| 1. Dealer from whom purchased | 5. Engine make and serial number |
| 2. Date of delivery | 6. Length of time in use |
| 3. Serial number of unit | 7. Date of failure |
| 4. Model number of unit | 8. Nature of failure |



EXPLANATION OF LIMITED WARRANTY

The manufacturer will not reimburse the customer or dealer labor cost incurred for installing “bolt-on” or “slip-on” items, such as pumps and motors, bearings, belts, pulleys, etc. The manufacturer will provide replacement parts at no cost to the customer for defective parts during the warranty period. Defective parts must be returned to J.P. Carlton Company. It will be the customers’ responsibility to install the replacement parts unless arrangements are made with the selling dealer.

The manufacturer will not reimburse travel cost to servicing dealer. It is the customers’ responsibility to deliver machine to dealers facility, unless other arrangements have been agreed to between the selling dealer and the customer.

The manufacturer may elect, at its discretion, to reimburse reasonable labor cost to customer or dealer for major defect repairs. Prior approval must be obtained from J.P. Carlton Company Inc.

IMPORTANT NOTICE

- 1. AIR FILTER MAINTENANCE IS CRITICAL ON STUMP GRINDING MACHINES. DIRT INGESTION WILL NOT BE WARRANTED BY THE ENGINE MANUFACTURER OR J.P. CARLTON COMPANY.**
- 2. OIL AND OIL FILTER MAINTENANCE AND STAYING WITHIN THE LIMITS OF THE ANGLE OF OPERATION IS ALSO CRITICAL ON STUMP GRINDING MACHINES. STARVING THE ENGINE FOR OIL WILL NOT BE WARRANTED BY THE ENGINE MANUFACTURER OR J.P. CARLTON COMPANY.**

Warranty Validation Form

Congratulations on your purchase of a Carlton Stump Grinder. This product has been designed and manufactured to provide years of profitable service while minimizing maintenance and downtime. Please take the time now to complete this warranty validation form. This information is necessary for Carlton to instate your warranty.

Return Form To: J.P. Carlton Company, Div. D.A.F. Inc.
121 John Dodd Road
Spartanburg, SC 29303
Phone: 1-864-578-9335

Purchaser Information:

Company Name: _____ Street Address: _____
City: _____ State: _____ Zip Code: _____
Telephone: _____ Contact: _____

Machine Information:

Model Number : _____ Engine Model : _____
Serial Number : _____ Serial Number : _____

Dealer Information:

Dealer Name: _____ Street Address: _____
City: _____ State: _____ Zip Code: _____
Contact Name: _____

1. _____ Customer has been instructed on operation and safety aspects of operating the equipment.
2. _____ Customer has been advised not to reach into cutter wheel area.
3. _____ Customer has been advised to stop machine and remove key before performing any type of maintenance.
4. _____ Customer has been warned not to operate the machine without the cutter wheel guard in place.
5. _____ Customer has been furnished with all parts and operators manuals.
6. _____ Customer has been instructed on equipment maintenance schedules and procedures.
7. _____ Customer has been advise that the engine or power unit that is used on this machine is warranted by the engine manufacturer and ***NOT J.P. Carlton Company***. All engine warranty issues should be addressed to the local engine dealer.
8. _____ Customer understands the importance of air and oil filter maintenance, and the importance of staying within the angle of operation of the engine. If either of these is not adhered to, the engine warranty is ***VOID***.
9. _____ Customer understands to keep locking collars tight and purge bearings with grease.
10. _____ All operation and warning decals are properly displayed on equipment.
11. _____ Customer understands it is his responsibility to train all operators on operator safety.

I have inspected this equipment and find it in good working condition. To the best of my knowledge, the customer and his personnel are aware of the above procedures.

Date: _____ Signed: _____
Dealer Representative

The equipment has been thoroughly checked by the above named dealer representative, and I am satisfied with his instructions.

Date: _____ Signed: _____
Purchaser

INTRODUCTION

FOREWORD	1
GENERAL INFORMATION	2
MACHINE FEATURES	3
MACHINE SPECIFICATIONS	4

OPERATION

SAFETY PRECAUTIONS	5
DAILY CHECKLIST	10
MACHINE CONTROLS	11
TRANSPORT MACHINE	20
MACHINE OPERATION	22

MAINTENANCE

MACHINE MAINTENANCE	26
LUBRICATION CHART	29
TROUBLESHOOTING GUIDE	30
SERVICING BELTS	32
SERVICING BEARINGS	42
SERVICING CUTTER WHEEL	44
SERVICING HYDRAULICS	51
WIRING DIAGRAM	54

PARTS

ENGINE BELT ASSEMBLY	55
POLY CHAIN® BELT ASSEMBLY	57
BACK	

COMPONENT INFORMATION

TRACK MAINTENANCE & PARTS	
PT TECH CLUTCH MANUALS	
NBB CONTROLER MANUAL	
RADIO CONTROL MANUAL	



Congratulations on your purchase of a new Carlton® Professional Stump Grinder! Carlton® Stump Grinders have a reputation for superior performance and reliability. A machine is not profitable if it's broken-down and we do our absolute *best* to help you avoid costly downtime. Each and every machine has been *over* designed and overbuilt to ensure years and years of trouble-free operation. In this, we take pride.

The Carlton® Hurricane track machine is designed and intended for use in unique situations where size and maneuverability are foremost. As a result, the Hurricane track machine has its own unique operational requirements.

Read this manual carefully and TAKE RESPONSIBILITY for thoroughly familiarizing yourself with the controls and the concepts behind the operation of this machine before attempting to operate it. Slowly experiment with the controls and gradually work yourself up to the full capabilities of this machine. The Carlton® Hurricane track machine is a durable and profitable professional stump grinder. Read this manual, the engine manual and the safety and operational decals on the machine. Use proper safety precautions. Follow the instructions and use common sense and your "OX" will perform like its namesake. If getting more work done in a day, with less trouble, is your idea of good business, then you'll *love* your new Carlton® Stump Grinder.

We welcome your suggestions on how we might better build our machines. We solicit any and all questions concerning the safe operation or proper servicing of your new stump grinder.

Please feel free to write to us with any comments.
We'll enjoy hearing from you!

The J. P. Carlton Company constantly strives to create the best equipment available in the stump cutting industry. Therefore, the material in this manual is correct at the time of publication. Carlton® reserves the right to make improvements, modifications and even discontinue features, as we deem necessary to meet our goal. Carlton® also reserves the right to discontinue models without any prior notification or obligation.

Inspect your new Carlton® Stump Grinder as soon as you receive it. Any damages incurred during shipment are not warranted and therefore not covered repairs. You should have the truck driver verify or acknowledge any damages caused during shipment. If not, contact the truck lines as soon as possible with your complaint.

Any reference made to right, left, front or rear in relationship to the stump cutter is illustrated in the following picture. Please refer to these any time you call your dealer or J. P. Carlton Company for parts or assistance.

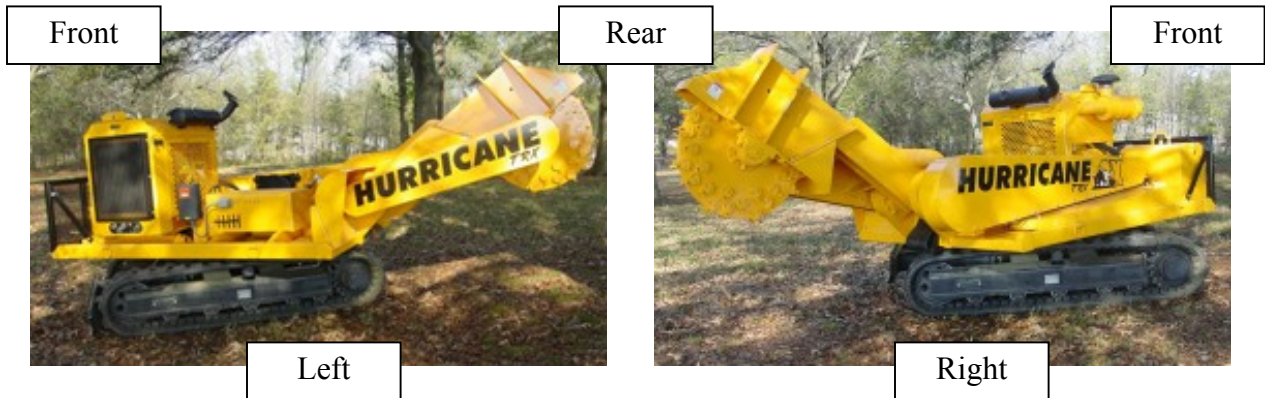



Available Machine Features:

- Proportional wireless remote control with tether back-up
- Continuous 360° rotation swing
- Swing motor brake lock
- Clutch actuated engine engagement
- RS – 81” track length
- RS – 12” track footprint
- TRX – 97” track length
- TRX – 16” track footprint
- Direct drive hydraulic pump
- Proportional solenoid operated
- Oil cooler with electric fan
- Hydraulic oil and fuel filters
- Large hydraulic oil reservoir with lockable cap cover & site glass for easy oil level check
- Large fuel tank with lockable cap cover
- **RS** – 48 Carbide tipped teeth
- **RS** –31” Diameter cutter wheel including teeth
- **TRX** – 64 Carbide tipped teeth
- **TRX** –36” Diameter cutter wheel including teeth
- 1 1/2” thick Blanchard ground cutter wheel
- Low maintenance drive belts
- Belt guards
- Tapered roller bearings
- Metal chip guards
- Air cleaner with service indicator
- High capacity battery
- Steel battery box
- Double wire braid hose
- Key switch
- High quality epoxy primer
- DuPont Imron® finish
- Hydraulic scrape blade

**We Pride Ourselves
in the strength and quality of each and every machine**



Hurricane RS

General:

Weight: ----- 8500 Pounds
Length: ----- 170"
Height: ----- 83"
Width: ----- 65"
Controls: ----- Wireless Remote w/ Tether
Back Up
Fuel Capacity: ----- 36 Gallons
Battery: ----- 800 CCA
Track Length: ----- 81"
Track Footprint: ----- 12"
Wireless Remote: ----- Full Proportional Control

Engine:

(Varies depending on selection of engine make & model)
Manufacturer: ----- John Deere 4045T Turbo Diesel
Number of Cylinders: -- Four
Bore: ----- 4.19 Inches (106 mm)
Stroke: ----- 5.0 Inches (127 mm)
Displacement: ----- 276 Cubic Inches (4.5L)
Maximum RPM: ----- 2400 RPM
Horsepower: ----- 125HP (93KW)
Torque: ----- 328 Ft Lbs (445Nm)
Cooling Medium: ----- Liquid Water/Antifreeze
Mixture
Air Cleaner: ----- Two Stage Dry Type
W/ Service Indicator
Oil Filter: ----- Full Flow Spin On
Electrical: ----- 12 Volt
Crank Shaft Support: --- Clutch Output
Gauges: ----- Oil Pres, Water Temp, Amp,
Tachometer

Bearings:

Jackshaft Bearings: ----- 2 7/16" Tapered Roller
Boom Bearings: ----- 3 15/16" Tapered Roller
Cutter Head Bearings: - 2 15/16" Tapered Roller
Swing Bearings: ----- 30" Kaydon Table Bearing
Rated at 250,000 ft. lbs.

Cutter Wheel

Wheel Diameter: ----- 31" with Teeth
Wheel Thickness: ----- 1 1/2" Blanchard Ground
Wheel Speed: ----- 860 RPM
Number of Teeth: ----- 48
Chip Guards: ----- 3/16" Steel Mounted

Cutting Dimensions

Below Ground ----- 25"
Above Ground ----- 53"
Cutting Width ----- 18' Diameter
Continuous 360° Rotation

Hydraulic System:

Hyd Pump Displcmnt: -Variable Displacement Pressure
Comp.
Hyd Pump Drive Sys: --Direct Drive off Engine Mount
Flow: ----- Variable
System Relief: ----- 2750 PSI
Oil Tank Capacity: ---- 31 Gallons
Oil Type: ----- AW32
Valve: ----- Proportional Solenoid Type
Hose: ----- 16,000 PSI Burst - Exceeds SAE
100R2
Oil Filter: ----- 10-Micron High Capacity Return
Lift Cylinder: ----- 4" x 16" with 1 3/4" Rod
Blade Cylinder: ----- 4" x 8" with 1 3/8" Rod
Swing Motor: ----- Continuous Rotation w/Brake Lock
Oil Cooler: ----- 190 Sq Inches w/ Electric Fan

Drive System:

Engine Sheave: ----- 6B8.0
Jackshaft Sheave: ----- 6B18.4
Drive Belt: ----- 6B173
Jackshaft Sprocket: ---- 14M-38S-125
Cutter Head Sprocket: -- 14M-56S-125
Drive Belt: ----- 14M-3136-125
Jackshaft: ----- 2 7/16"
Cutter Head Shaft: ----- 3" Turned to 2 15/16" @ Bearing
Engine Engagement: --- Clutch Actuated
Belt & Chain Shields: -- 3/16" Metal Bolt On

Frame:

Frame Tube: ----- 4" x 8" with 1/2" Wall
Boom Tube: ----- 6" x 6" with 1/2" Wall
Boom Box: ----- 3/8" Fabricated Plate
Bearing Supports: ----- 1 1/2" Plate
Turntable Plate: ----- 1" Plate
Turntable Frame: ----- 2" x 5" Tube with 3/8" Wall
Inner Frame: ----- 2" x 3" Tube with 1/4" Wall
Brush Guard: ----- 2" x 2" Tube with 1/4" Wall
Perforated Guard: ----- 1/8"

Hurricane TRX

General:

Weight: ----- 12500 Pounds
Length: ----- 185"
Height: ----- 83"
Width: ----- 78"
Controls: ----- Wireless Remote w/ Tether
Back Up
Fuel Capacity: ----- 50 Gallons
Battery: ----- 800 CCA
Track Length: ----- 97"
Track Footprint: ----- 16"
Wireless Remote: ----- Full Proportional Control

Engine:

(Varies depending on selection of engine make & model)
Manufacturer: ----- John Deere 4045T Turbo Diesel
Number of Cylinders: -- Four
Bore: ----- 4.19 Inches (106 mm)
Stroke: ----- 5.0 Inches (127 mm)
Displacement: ----- 276 Cubic Inches (4.5L)
Maximum RPM: ----- 2400 RPM
Horsepower: ----- 125HP (93KW)
Torque: ----- 328 Ft Lbs (445Nm)
Cooling Medium: ----- Liquid Water/Antifreeze
Mixture
Air Cleaner: ----- Two Stage Dry Type
W/ Service Indicator
Oil Filter: ----- Full Flow Spin On
Electrical: ----- 12 Volt
Crank Shaft Support: --- Clutch Output
Gauges: ----- Oil Pres, Water Temp, Amp,
Tachometer

Bearings:

Jackshaft Bearings: ----- 3 3/16" Tapered Roller
Boom Bearings: ----- 4 7/16" Tapered Roller
Cutter Head Bearings: - 2 15/16" Tapered Roller
Swing Bearings: ----- 30" Kaydon Table Bearing
Rated at 250,000 ft. lbs.

Cutter Wheel

Wheel Diameter: ----- 36" with Teeth
Wheel Thickness: ----- 1 1/2" Blanchard Ground
Wheel Speed: ----- 860 RPM
Number of Teeth: ----- 64
Chip Guards: ----- 3/16" Steel Mounted

Cutting Dimensions

Below Ground ----- 25"
Above Ground ----- 72"
Cutting Width ----- 19' Diameter
Continuous 360° Rotation

Hydraulic System:

Hyd Pump Displcmnt: -Variable Displacement Pressure
Comp.
Hyd Pump Drive Sys: --Direct Drive off Engine Mount
Flow: ----- Variable
System Relief: ----- 2750 PSI
Oil Tank Capacity: ----- 42 Gallons
Oil Type: ----- AW32
Valve: ----- Proportional Solenoid Type
Hose: ----- 16,000 PSI Burst - Exceeds SAE
100R2
Oil Filter: ----- 10-Micron High Capacity Return
Lift Cylinder: ----- 4" x 16" with 1 3/4" Rod
Blade Cylinder: ----- 4" x 8" with 1 3/4" Rod
Swing Motor: ----- Continuous Rotation w/Brake Lock
Oil Cooler: ----- 190 Sq Inches w/ Electric Fan

Drive System:

Engine Sheave: ----- 8B6.8
Jackshaft Sheave: ----- 8B18.4
Drive Belt: ----- 8B195
Jackshaft Sprocket: ----- 14M-38S-125
Cutter Head Sprocket: -- 14M-40S-125
Drive Belt: ----- 14M-3500-125
Jackshaft: ----- 3 3/16"
Cutter Head Shaft: ----- 3" Turned to 2 15/16" @ Bearing
Engine Engagement: --- Clutch Actuated
Belt & Chain Shields: -- 3/16" Metal Bolt On

Frame:

Frame Tube: ----- 4" x 8" with 1/2" Wall
Boom Tube: ----- 6" x 6" with 1/2" Wall
Boom Box: ----- 3/8" Fabricated Plate
Bearing Supports: ----- 1 1/2" Plate
Turntable Plate: ----- 1" Plate
Turntable Frame: ----- 2" x 5" Tube with 3/8" Wall
Inner Frame: ----- 2" x 3" Tube with 1/4" Wall
Brush Guard: ----- 2" x 2" Tube with 1/4" Wall
Perforated Guard: ----- 1/8"

Before operating the stump cutter, read this manual, the engine manual, and all the safety decals on the machine. Know all parts of the machine and their functions, especially the shut down procedures in case of emergency. No inexperienced person may operate machine. Inexperience may cause injury.

SAFETY FIRST ALWAYS!

This is the **Safety-Alert Symbol**. This symbol is placed on the machine and in the manual to alert the operator to the potential for bodily injury or death. The operator should pay close attention to the instructions whenever they see this symbol.



The **Safety-Alert Symbol** will be accompanied by one of the following words:

DANGER, WARNING, or CAUTION

- A **DANGER** symbol means that if the instructions are not followed the possibility of serious personal injury or death is probable.
- A **WARNING** symbol means that if the instructions are not followed there is a possibility of serious personal injury or death.
- A **CAUTION** symbol means there is an unsafe condition or practice that may cause personal injury or property damage.

PERSONAL PROTECTION:

- ❖ Wear face shield and hearing protection
- ❖ Do not wear loose-fitting clothing
- ❖ Tie back long hair
- ❖ Do not wear jewelry
- ❖ Keep clear of cutter wheel
- ❖ Keep away from moving parts
- ❖ Only operate in a well ventilated area because of carbon monoxide

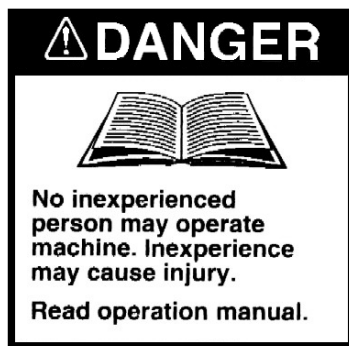
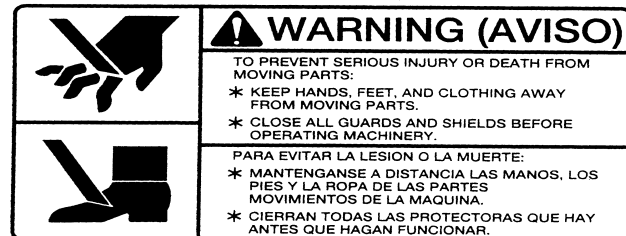

P/N 0700008



P/N 0700010



P/N 0700027

Be Safe and Practice Safe Operation using the following guidelines.



- Any individual operating this machine must first read and understand this manual, the engine manual, all component manuals, and all safety decals on machine.
- DO NOT permit children to operate machinery or to play near machinery during operation.
- Always wear face shield and hearing protection during operation. Loud noise and flying debris may cause severe injury.
- Keep hands, feet, legs, clothing, hair and all other body parts away from cutter wheel and other moving machine parts to eliminate the possibility of injury.
- Use extreme care when positioning the machine using the hand controls, if the operator's foot or leg gets run over by the track severe injury will occur.
- DO NOT operate the swing lever when operating hand controls. KEEP the swing motor in the locked position when operating hand controls or when servicing the machine.
- **BE AWARE** that the machine table rotates when the swing rotation is activated. All people must stay clear of machine when swing rotation is activated.
- Shut down machine completely and remove key before removing debris from work area (i.e. clearing rocks, wood chips, etc.).
- DO NOT modify or change any part without written approval from J. P. Carlton Company.
- Do not ride, sit, stand, lay or climb anywhere on this machine during operation, while running, or during transport.
- Do not move, position, or transport this machine while cutter wheel is engaged.
- Do not refill fuel tank while engine is hot, running, or indoors. Danger of fire or explosion exists.
- Fuel and its vapors are highly flammable and explosive. **Handle with care.** Only use approved (red) fuel containers for storage.
- Do not store fuel containers near any open flames, sparks or other sources of ignition.
- Do not store equipment with fuel in the tank.





- Battery fumes are explosive. Recharge battery in an open area away from fire, sparks, or other sources of ignition.
- Battery acid can cause severe burns. Keep away from eyes, skin, and clothing.
- Always remove battery before welding on equipment.
- **PT TECH HPTO WARNING:** to avoid any electrical malfunction, the user should disconnect the wiring harness from the controller when welding on the equipment. Failure to do so may result in loss of controller warranty.



- **DO NOT OPERATE THE ENGINE AT AN ANGLE GREATER THAN 25° OR SEVERE ENGINE DAMAGE WILL OCCUR. PROPER ENGINE OIL LEVEL MUST BE MAINTAINED TO ACHIEVE MAXIMUM ANGLE OF OPERATION OF 25°. (See Engine Owner's Manual for proper oil level.)**
- Never allow spectators to stand and watch machine in operation without proper hearing and eye protection and standing at a safe distance. Flying debris may cause severe injury.
- Do not operate around water, gas, power or phone lines. Check with property owner or call utilities if not sure.
- Avoid fences and clear away other objects (i.e. sticks, stones, metal, etc.).
- Be aware of the possibility of foreign objects imbedded in or buried around the stump. Do not cut crosswise of roots above ground to prevent roots being thrown.
- If unusual vibration occurs, stop engine immediately and correct problem before continuing operation.
- Keep all guards in place and properly secured during operation.
- Keep all safety devices working properly and all other machine parts in good working condition.
- Never leave the controls unattended while in operation. Be sure machine is not capable of operation when left unattended.



- Stop engine and remove key when repairing or adjusting machine or drive belts.
- Keep engine in good condition, service as instructed in engine manual.
- Do not touch engine while running or hot (serious burns may result).

 **WARNING**

 **CAUTION**

- Allow all machine parts to cool sufficiently before servicing or making adjustments. Hot machine parts can cause severe burns.
- Do not run the machine without a complete number of teeth in the cutter wheel tightened to the correct torque.
- Park machine on level surfaces only. Lower cutter head to the ground.

- Do not operate stump cutter in dark, dim lit, or concealed areas.
- Keep machine clean and clear of debris to eliminate fire hazard. It is especially important to clean any oil or fuel spills.
- Keep all chip guards in place and secured properly.
- Keep safety and instructional decals clean and replace any that are damaged, difficult to read, or missing. Decals may be purchased from J.P. Carlton or an authorized dealer.

DAILY CHECKS SHOULD BE PERFORMED BEFORE STARTING ENGINE FOR THE DAY. **DO NOT** INSERT KEY INTO ENGINE UNTIL ALL CHECKS HAVE BEEN COMPLETED.

- Check engine oil at dipstick, located inside the cover of the engine. **Engine must be level.** Boom in raised position will not affect the engine position; machine must be on level ground. Add recommended oil as required (see engine manual).
- Check fuel filter for debris or water.
- Replenish fuel tank with fresh fuel.
- Check radiator coolant. Refer to engine manual for additional information. Radiator screen must be kept clear of debris, clean daily; blow off screen from the inside of the engine cover.
- Check hydraulic oil level. A sight glass is located on the tank. Add oil if required. Do not fill tank full, the oil will expand and spill out in hot temperatures.
- Check condition and tightness of drive belts.
- Check for any loose, broken, or missing cutter teeth and pockets.
- Inspect bolts, hydraulic fittings, wiring harnesses, hoses, and equipment for tightness, wear, or leakage. Make repairs as needed.
- Inspect air filters. **REPLACE**, if necessary, **WITH FACTORY AIR FILTER ONLY** (see Maintenance Section for part numbers). Do not blow out filters or tap filters on the ground. Replace the main filter when dirty. Replace inner safety filter when dirty or when the outer air filter has been changed 3 times. Follow engine manual procedure for removal and replacement. Do not allow dirt to get into engine when removing filters. Dirt ingestion will cause engine failure and is not warranted.
- Grease jackshaft and boom bearings daily, apply only 2 to 4 shots of grease. **DO NOT OVER GREASE.**
- Purge cutter wheel bearings with grease daily until clean grease is seen.
- Check condition of tracks and adjust tension if necessary (see Servicing Tracks section). Apply grease as required to keep track tension adjusted. **DO NOT OVER GREASE.**



OIL DIPSTICK INSIDE ENGINE COVER



REMOVE BACK ENGINE COVER & CLEAN RADIATOR SCREEN

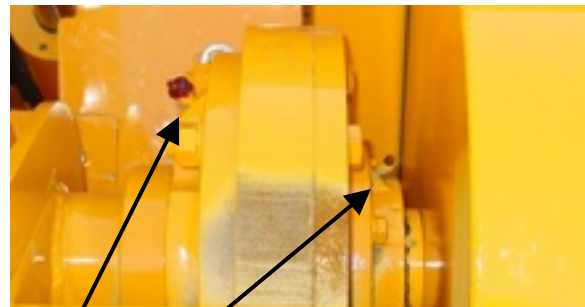

BOOM, JACKSHAFT, & CUTTER WHEEL BEARINGS

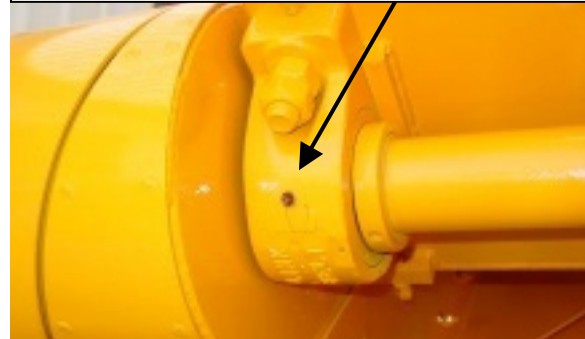

ENGINE CONTROLS – Refer to the engine manufacturer’s operating manual for controls, operation and service. **Never weld on a machine without disconnecting the ECU on the engine. DO NOT OPERATE THE ENGINE AT AN ANGLE GREATER THAN 25° OR SEVERE ENGINE DAMAGE WILL OCCUR.** PROPER ENGINE OIL LEVEL MUST BE MAINTAINED TO ACHIEVE MAXIMUM ANGLE OF OPERATION OF 25°. (See Engine Owner’s Manual for proper oil level.)

- The Hurricane track machine must be started using the key switch on the panel. This switch starts the engine and enables the machine mounted and radio control functions. Before starting the radio control transmitter, start the machine.
- On the machine, the Speed switch must be in the low position and the Swing Brake switch must be in the locked position before starting the transmitter.

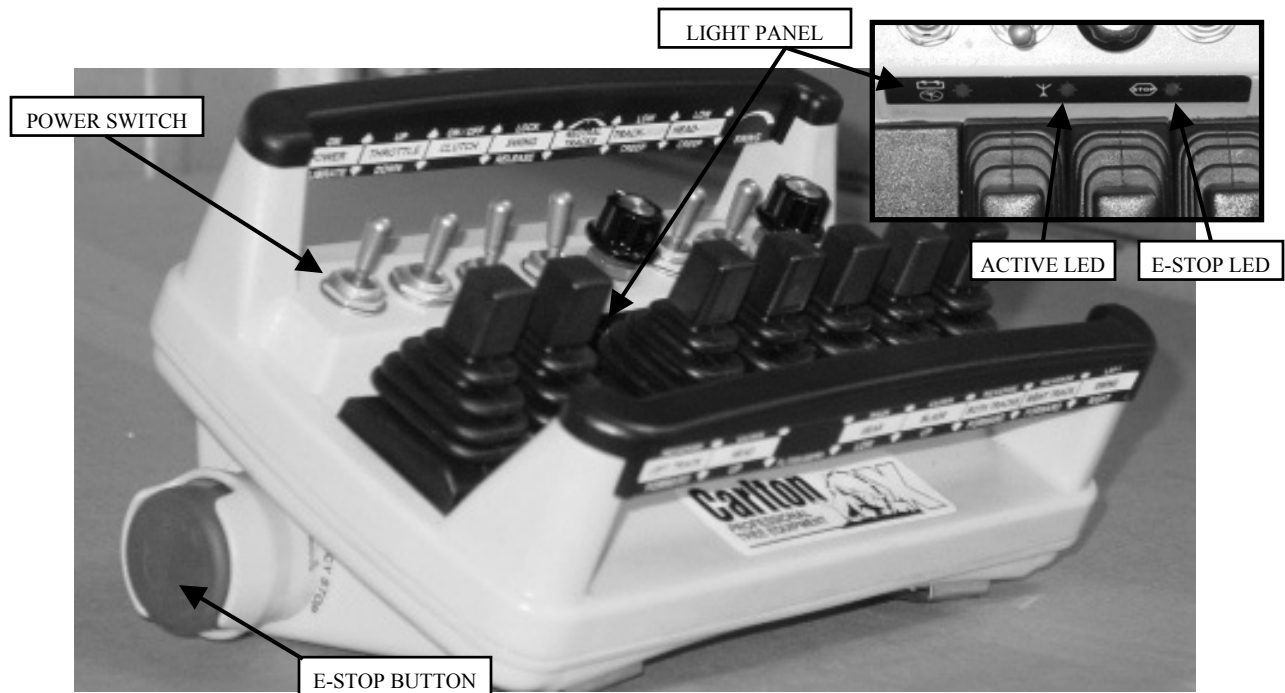
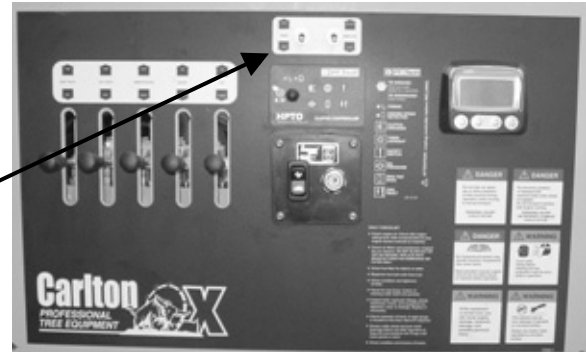

- To activate the transmitter for radio control operation, make sure all switches and paddles are in the Off, Neutral, or Lock position.
- Press the E-STOP button to make sure it is locked.
- Press the POWER switch to ON and release.

- The E-STOP light will flash red quickly.
- Release the E-STOP button by twisting it clockwise. Release the E-STOP button within 10 seconds or the unit will power down.
- The Active light will flash yellow.
- Test controls for proper operation.

Read the radio control manual supplied in the back of this manual for more information.

HYDRAULIC CONTROLS

- A series of hydraulic controls are located on the radio control transmitter and are clearly marked for operation. All machine controls are operated from the radio control transmitter.



SWITCH FUNCTIONS

RIGHT TRACK – LEFT TRACK

- The radio control transmitter has right and left track paddles as well as a paddle for both tracks. To operate the paddles push them toward the direction you want to move (Fwd or Rev). Use both right and left track paddles in the same direction (Fwd/Fwd or Rev/Rev) to move machine forward or reverse. Use paddles opposite (Rev/Fwd or Fwd/Rev) of each other to turn machine either right or left. When rotating the machine, do not leave one track stationary while rotating the other one around it as this could cause the machine to jump a track. If it is desired to spin the machine, counter-rotate the tracks.
- The Both Tracks paddle will move both tracks in the same direction, forward or reverse.
- The neutral Tracks knob will allow the operator to turn the tracks left or right by twisting the knob in the left or right direction.
- The Track HIGH (speed) switch will reduce the power of the track function paddles. The High position is for maximum power (speed) to move the machine quickly around the job site. Use the Low or Creep speeds for easier placement around the stump or for more climbing torque.



PADDLE FUNCTIONS

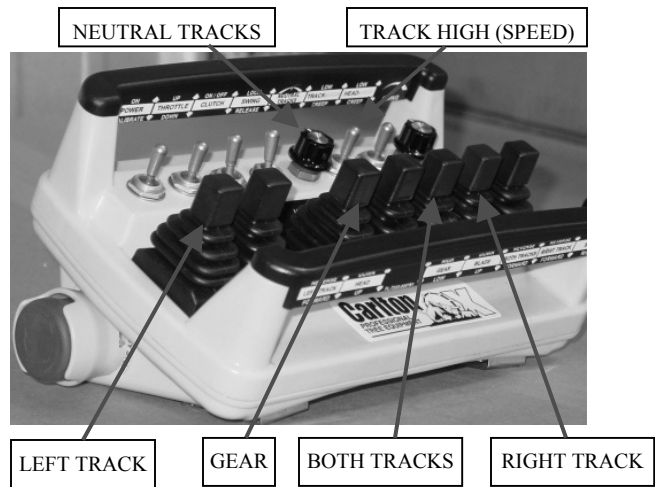
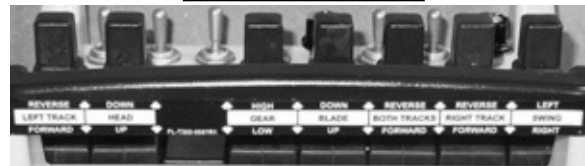

THE RADIO CONTROL TRANSMITTER WITH YOUR MACHINE MAY LOOK DIFFERENTLY. THE SPEED CONTROLS KNOBS MAY BE SWITCHES INSTEAD BUT THEY WILL PROVIDE THE SAME FUNCTION.

GEAR

- The Gear paddle allows the operator to change from low to high gear. In low gear the tracks have maximum torque and more climbing power while in high gear the tracks provide maximum speed.

NEVER WELD ON A MACHINE WITH RADIO CONTROLS WITHOUT FIRST DISCONNECTING THE RECEIVER WIRE HARNESS, OTHERWISE THE RADIO RECEIVER WILL BE DESTROYED.

SWING PADDLE

- The swing paddle controls the rotation and moves the machine back and forth in a right and left direction as well as a continuous 360° rotation.
- The swing knob controls how fast the machine moves back and forth when operating the swing paddle. Turn the knob clockwise to increase swing speed or counter-clockwise to decrease swing speed. The swing needs to be set at a speed that will allow smooth sweeping cuts across the stump. If the machine swings in jerking or jumping movements, reduce swing speed.

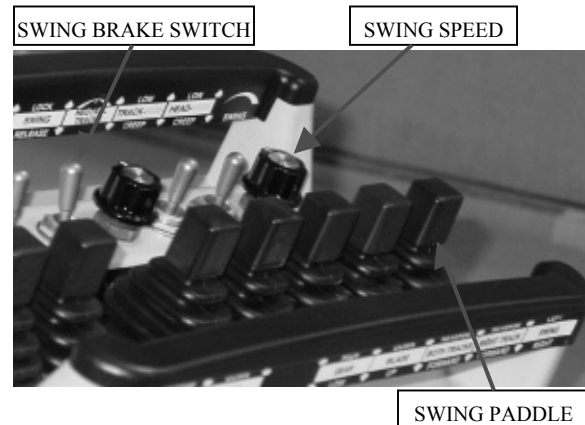

SWING SWITCH

- The swing switch locks or releases the swing brake. The Swing Brake must be locked to start the transmitter. Keep the swing brake locked when the engine is turned off; if a person must be close to the machine for any reason; the machine is being transported; for travel to, from and around the job site; or if the machine is to be serviced. The brake must be unlocked to operate the swing paddle and move the machine from left to right to grind the stump.

HEAD (LIFT)

- The paddle marked Head lifts the cutter head up and down. The switch marked Head controls the power supplied to the paddle. To decrease lift speed push the switch to low or creep.

BLADE

- The Blade paddle operates the scrape blade, when supplied, moving it up and down. Use the scrape blade by pushing the paddle in the **DOWN** direction, as marked on the transmitter. When not in use or when moving the machine, raise the scrape blade by pulling the paddle in the **UP** direction, as marked on the transmitter.

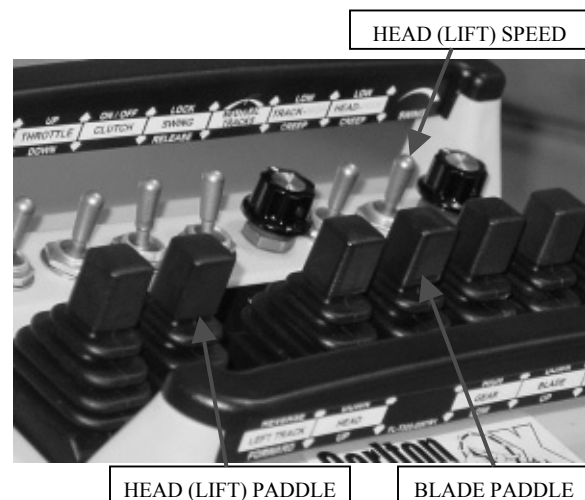

THROTTLE

- The radio control transmitter has a throttle switch for the operator to control the engine speed. Push the switch away from the operator to increase the engine speed and pull the switch toward the operator to decrease engine speed. **The engine speed must be at idle to engage the cutter wheel.**

CLUTCH

- The clutch can be engaged from the transmitter. To start engagement of the clutch, make sure the engine is at idle and push the clutch switch away from the operator. The switch must be held in this position for 3 seconds to allow the clutch to start to engage thus engaging the cutter wheel. There is more information about the PT Tech clutch supplied later in this section of the manual.

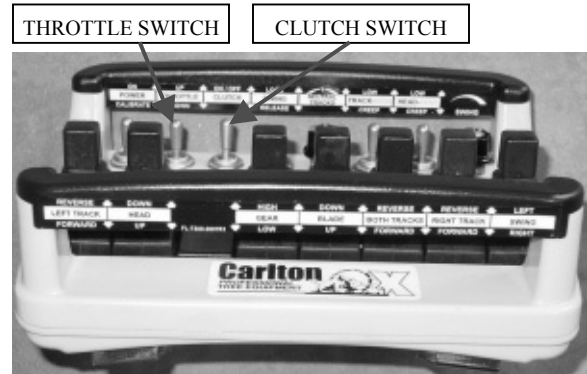

MACHINE HYDRAULIC CONTROLS

- A series of hydraulic controls are located on the radio control transmitter and the machine and are clearly marked for operation. **DO NOT USE THE MACHINE MOUNTED CONTROLS TO GRIND STUMPS.** The machine mounted control levers are to be used only for positioning the machine at slow speeds and to check hydraulic operation.



RIGHT TRACK – LEFT TRACK

- The first two machine levers, control the forward and reverse movement of the right and left tracks. Use both controls in the same direction (Fwd/Fwd or Rev/Rev) to move machine forward or reverse. Use controls opposite (Rev/Fwd or Fwd/Rev) of each other to turn machine either right or left. When rotating the machine, do not leave one track stationary while rotating the other one around it as this could cause the machine to jump a track. If it is desired to spin the machine, counter-rotate the tracks.

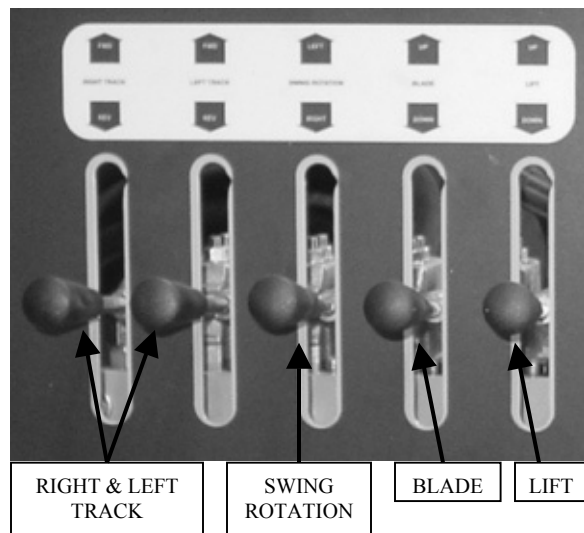

SPEED

- The Speed switch on the machine changes the track drive motors from low to high gear. In low gear the tracks have maximum torque and more climbing power while in high gear the tracks provide maximum speed.

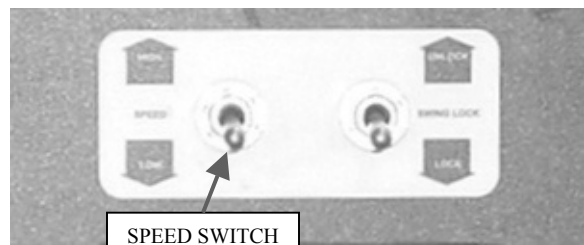

LIFT

- This lever lifts the cutter head up and down for positioning the cutter wheel at the top of the stump and grinding it well below ground level.



SWING ROTATION

- The third lever, in the middle, is the swing rotation and moves the machine back and forth in a right and left rotation as well as a continuous 360° rotation. **DO NOT GRIND STUMPS USING THE MACHINE MOUNTED SWING ROTATION LEVER.**



SWING BRAKE

- The swing brake switch locks or unlocks the swing brake. The brake must be unlocked to operate the swing rotation lever and move the cutter head from left to right. Keep the swing brake locked when the engine is turned off; if a person must be close to the machine for any reason; the machine is being transported; for travel to, from and around the job site; or if the machine is to be serviced.

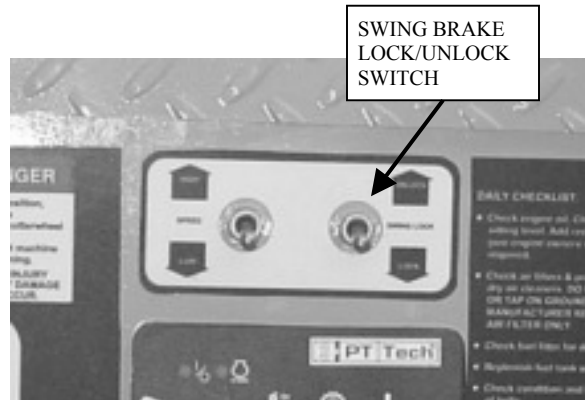

SCRAPE BLADE

- The fourth lever, from the left, operates the scrape blade, when supplied, moving it up and down. Use the scrape blade by pushing the control lever down. When not in use or when moving the machine, raise the scrape blade by pushing the control lever up.



MURPHY BY-PASS

- The Murphy control is a by-pass that automatically determines if conditions are correct for starting the engine and also displays engine problems such as oil temperature and oil pressure.



PT TECH CLUTCH CONTROL

- The PT TECH Clutch control console is located at the operators' station. The engine must be at idle to engage or disengage the PT TECH clutch. With the engine at idle hold the engage/disengage button until the green engage light comes on. The PT TECH clutch will now go through a series of bumps to get the cutter wheel started.
- The Power LED light in the upper left illuminates green to show the clutch is receiving switched power from the ignition.
- The Engine Speed Detected LED light illuminates when the engine is running.
- The green Clutch Engaged symbol illuminates when the clutch is engaged.
- The red RPM Too High symbol illuminates if the operator tries to engage the clutch with the engine above idle.



NOTE: UNPLUG CONTROLLER BEFORE WELDING ON MACHINE

Please refer to the PT TECH Manual for more information regarding the clutch.

SAFETY

- **NEVER SERVICE A MACHINE WITH THE ENGINE RUNNING, SEVERE PERSONAL INJURY COULD OCCUR. TURN ENGINE OFF THEN REMOVE IGNITION KEY AND DISCONNECT POSITIVE BATTERY CABLE TO AVOID STARTING MACHINE ACCIDENTALLY.**
- **CUTTER WHEEL MUST BE DISENGAGED BEFORE TURNING ENGINE ON/OFF AND BEFORE SERVICING A MACHINE. OTHERWISE SEVERE PERSONAL INJURY COULD OCCUR AS WELL AS MACHINE DAMAGE.**
- **ALL MACHINE PARTS MUST COME TO A COMPLETE STOP AND HAVE TIME TO COOL COMPLETELY BEFORE SERVICING A MACHINE OR SEVERE INJURY COULD OCCUR, POSSIBLY SERIOUS BURNS AND/OR DISMEMBERMENT.**
- **PLACE THE CUTTER WHEEL ON THE GROUND WHEN PERFORMING SERVICE ON A MACHINE.**

PROGRAMMING – RADIO (WIRELESS) TRANSMITTER

- If there is a problem with the receiver or the transmitter and either has to be replaced, you will need to program the new unit to communicate with the existing unit. Or if you have more than one transmitter for this machine, it will need to be programmed to communicate with the existing receiver.
- To program the transmitter and receiver, you have to download the transmitter's unique code into the receiver. There are complete instructions along with colored illustrations in the radio control manual included in the back of this manual.
- To access the receiver, remove the machine control panel cover.
- Remove the radio receiver panel by unlatching the plastic tabs on either side of the receiver; see the radio control manual included in this manual at the back. The receiver panel will now slide out of the cap.
- Follow the instructions in the radio control manual, included at the end of this manual, to download the ID Code. There are specific instructions that need to be followed and corresponding illustrations. Be sure to push the receiver panel back up into the cover until the tabs snap back into place.



TROUBLESHOOTING

SEE THE RADIO CONTROL MANUAL FOR ANY OPERATING PROBLEMS WITH THE RADIO RECEIVER & TRANSMITTER

(Included in the back of this manual)

- Contact your Carlton dealer if you need assistance not the radio control manufacturer.
- Check the batteries to make sure they are providing enough power to operate the transmitter.
- There is a low battery light on the transmitter, when it starts flashing you have approximately 10 hours of operation before the batteries die.
- Remove the cover on the transmitter. Remove old batteries and replace with new batteries. The transmitter operates using 4 - "C" alkaline batteries.
- Next, open the cover on the machine control box. You will need to be able to see the lights on the receiver to compare to the trouble indicators on the receiver diagnostic list in the radio control manual. Check the light configuration and compare it to the Diagnostic lists in the radio control manual. If necessary, check the Expansion Module in the same manner.
- If the radio receiver or expansion module status light is flashing red, a fuse is blown. To change a fuse, remove the unit from the cover and change the fuse. Inspect wiring for short circuits (e.g. bare wires). If problem re-occurs, call for service. Push the unit back up into the cover until the tabs snap back into place.
- Always replace the machine control panel cover when service is complete. **DO NOT RUN MACHINE WITHOUT ALL GUARDS & COVERS IN PLACE AND SECURED.**

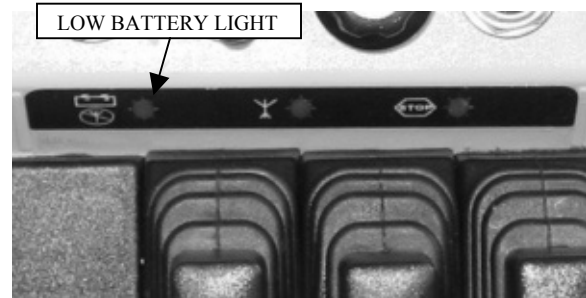

REMOVE THE BACK COVER TO ACCESS THE BATTERIES – THERE ARE 4 SCREWS HOLDING IT IN PLACE. THE BATTERY COMPARTMENT IS LABELED FOR CORRECT BATTERY ORIENTATION.

RELEASE THE RADIO RECEIVER CAP BY UNLATCHING THE TABS ON EACH SIDE AND DROP THE RECEIVER UNIT DOWN FOR SERVICE

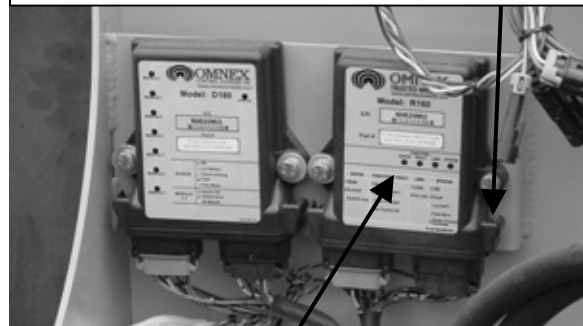

REFERENCE THE LIGHT CONFIGURATION ON THE RECEIVER TO THE DIAGNOSTIC CHART IN THE RADIO CONTROL MANUAL

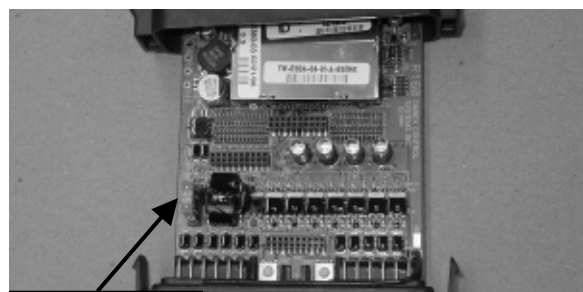

REPLACE FUSE



DO NOT TOW! THE HURRICANE *TRX* IS DESIGNED TO BE TRANSPORTED TO THE JOB SITE AND WILL MOVE UNDER ITS OWN POWER ONCE ON SITE.



SECURE HURRICANE TRACK MACHINE TO TRAILER USING TIE DOWN STRAPS ATTACHED TO THE TIE DOWN RINGS ON THE SIDE OF THE MACHINE.

The Hurricane *TRX* requires a lowboy trailer that will support and carry 12000 pounds. The Hurricane RS requires a trailer rated for at least 10000 lbs.

- **THE TRAILER MUST BE SECURELY ATTACHED TO THE TOW VEHICLE BEFORE LOADING OR UNLOADING THE STUMP GRINDER.**
- **LOADING RAMPS MUST BE STURDY AND SECURELY ATTACHED TO THE TRAILER BEFORE ATTEMPTING TO LOAD OR UNLOAD THE MACHINE.**
- **Check trailer for security and make sure chains are properly installed.**
- **Check tires inflation.**
- **Check trailer lights for proper operation.**
- **Never transport the machine with the engine running.**
- **Towing will affect handling. Allow for extra stopping distances.**
- **Start and stop gradually.**
- **Tow at a safe reasonable speed.**

- **THE TRAILER MUST BE SECURELY ATTACHED TO THE TOW VEHICLE BEFORE LOADING OR UNLOADING THE STUMP GRINDER.**
- **DO NOT LOAD OR UNLOAD ON ANYTHING OTHER THAN LEVEL GROUND.**

LOADING

- Start the machine using the key-switch on the machine control panel and turn on the radio control and push the ON button.
- Increase engine RPM and raise cutter head to clear the ground.
- Position the machine behind the trailer and close to the loading ramps. Push the forward track controls on the remote control and watch closely to make sure both tracks stay on the ramps while loading. **KEEP THE MACHINE AS LEVEL AS POSSIBLE.**
- Continually adjust the cutter head height as you go up the ramps, keeping the mass as low to the ground as possible, especially if you load the machine with the cutter wheel first.
- When the machine is loaded, lower the cutter head and turn off the machine.
- Secure the machine tightly with sufficient tie downs to prevent any movement in transit.

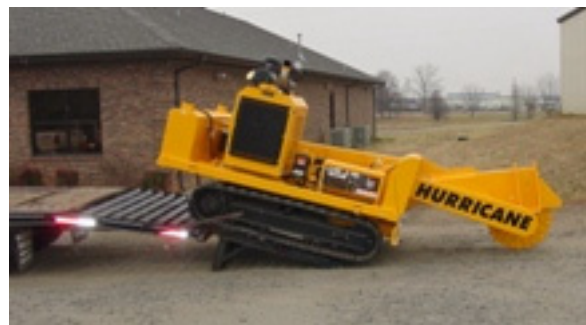

UNLOADING

- With trailer still securely attached to tow vehicle, remove tie down straps and make sure ramps are securely attached to trailer and positioned correctly to unload the machine.
- Start machine using the key-switch on the machine control panel. Turn on the radio control and push the ON button, increase engine RPM, and raise cutter head to clear the deck and ramp.
- Continually adjust the cutter head up and down to keep the mass as low to the ground as possible. Watch to make sure both tracks stay on the ramps.
- Raise cutter head and proceed to the work site using extreme caution on hills and uneven terrain. Use the gear and flow controls in high position to get to the job site faster and use the gear and flow controls in low to make climbing easier. See the Machine Controls section for more information.

STARTING – ALL OPERATORS MUST READ THIS MANUAL, ALL MACHINE DECALS, AND THE ENGINE AND OTHER COMPONENT MANUALS BEFORE STARTING.

- **ALWAYS PERFORM DAILY CHECKLIST BEFORE STARTING MACHINE FOR THE DAY. REPLENISH FUEL AND OIL DAILY.**
- **AVOID TRANSVERSING SLOPES. ASCEND/DESCEND HILLS STRAIGHT UP AND DOWN NEVER STRAIGHT ACROSS.**
- **DO NOT OPERATE THE ENGINE AT AN ANGLE GREATER THAN 25° OR SEVERE ENGINE DAMAGE WILL OCCUR. PROPER ENGINE OIL LEVEL MUST BE MAINTAINED TO ACHIEVE MAXIMUM ANGLE OF OPERATION OF 25°. (See Engine Owner’s Manual for proper oil level.)**
- **DO NOT OPERATE AROUND WATER, GAS, POWER, OR PHONE LINES. IF IN DOUBT, CHECK BEFORE GRINDING.**
- **WEAR FACE SHIELD AND HEARING PROTECTION.**
- **KEEP CLEAR OF CUTTER WHEEL AND MOVING MACHINE PARTS.**
- **ONLY USE THE MACHINE CONTROL LEVERS FOR SLIGHT POSITIONING ADJUSTMENTS.**
- **NEVER OPERATE THE SWING FUNCTIONS USING THE MACHINE CONTROL LEVERS. ALWAYS KEEP THE SWING BRAKE LOCKED WHEN OPERATING THE MACHINE CONTROL LEVERS FOR POSITIONING.**
- **DO NOT OPERATE A MACHINE WITHOUT A COMPLETE NUMBER OF TEETH IN THE CUTTER WHEEL PROPERLY INSTALLED. EXCESSIVE MACHINE VIBRATION WILL OCCUR CAUSING PREMATURE BEARING FAILURE AND EQUIPMENT DAMAGE.**
- **KEEP SPECTATORS AWAY FROM WORK AREA.**

- The Hurricane track machine must be started using the key switch on the panel. This switch starts the engine and enables the machine mounted and radio control functions.
- **The Swing Lock switch on the panel must be in the Lock position and the Speed switch must be in the Low position before starting the engine.**
- Before starting the radio control transmitter, start the machine.
- To activate the transmitter for radio control operation, make sure all switches and paddles are in the Off, Neutral, or Lock (centered) position.
- Press the E-STOP button to make sure it is locked.
- Press the POWER switch to ON and release.

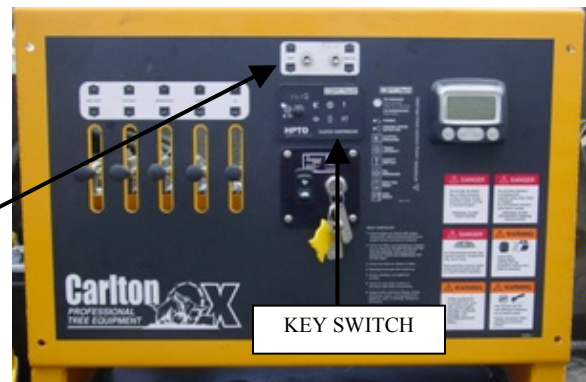

- The E-STOP light will flash red quickly.
- Release the E-STOP button by twisting it clockwise. Release the E-STOP button within 10 seconds or the unit will power down.
- The Active light will flash yellow.
- Test controls for proper operation.

Read the radio control manual supplied in the back of this manual for more information.



- Position machine at stump with cutter wheel a slight distance from stump. **Do not position machine near stump with the cutter wheel engaged.**
- Raise cutter wheel clear of stump.
- With engine at idle; engage clutch by pushing the Clutch ON/OFF switch up on the radio control transmitter and hold for 3 seconds.

THE PT TECH CLUTCH WILL ONLY ENGAGE WITH THE ENGINE SPEED AT IDLE (BELOW 1100 RPM). CHECK ENGINE RPM IF CLUTCH WILL NOT ENGAGE. (Read the PT Tech clutch manual.)

- When started, the PT Tech Clutch will automatically go through a series of bumps to bring the cutter wheel up to speed.
- When clutch and cutter wheel are fully engaged and cutter wheel is running smoothly, increase engine speed to full by pushing the engine throttle switch up. **DO NOT increase engine speed while the clutch is engaging or a fault will occur and you will have to start over with the engine below 1100 RPM.**



THROTTLE SWITCH - ENGINE RPM

CLUTCH ON/OFF SWITCH



ENGINE RPM TO HIGH INDICATOR - MACHINE CONTROL PANEL

- Release the swing brake by pressing the switch down and test cutter wheel swing controls for proper operation. **DO NOT ALLOW ANYONE TO BE NEAR THE MACHINE WHEN THE SWING IS BEING OPERATED. THE ENTIRE MACHINE UPPER FRAME ROTATES WHEN THE SWING IS OPERATED.**
- The cutter head should be moved back and forth in a smooth, flowing manner. The radio control is a proportional controller meaning that the amount of pressure applied to the control determines the speed of the function. Understanding how the radio control works will enable the operator to develop a technique of smooth operation for the cutter head swing, read the radio control manual supplied in this manual.
- The Head (LOW/CREEP) switch will reduce the power to the cutter head swing function. The middle position of the switch is HIGH or full power. Push the switch up to reduce cutter head speed slightly or push the switch to creep for the slowest cutter head speed. Use this switch with the swing speed knob to fine-tune the swing speed of the cutter head.
- If jerking, bouncing, or significant drops in engine speed occur, swing rate is too rapid and must be decreased. Use these switches to get a smooth back and forth cutting action.
- Lower the spinning cutter wheel to stump and make a few light passes at stump to get a feel for the cutting action.
- Gradually increase cutting action and work away at stump by swinging cutter wheel left-to-right-to-left through stump in a sideways motion. Smooth, effortless cutting lengthens machine life, minimizes downtime, and is more profitable in the long run.

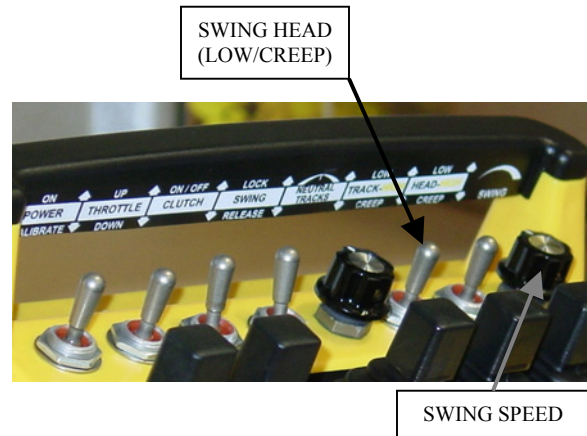
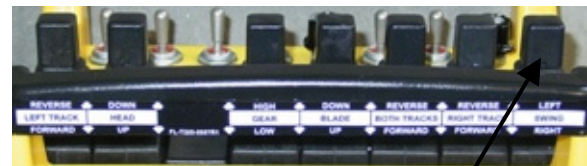
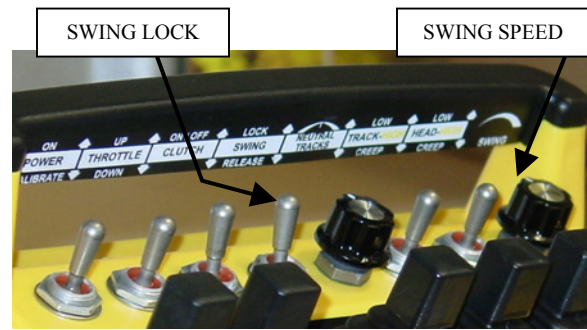

- Continue cutting the stump by adjusting the cutting head progressively lower until the stump is cut well below ground level.
- Raise and swing cutter wheel clear of stump and position machine closer to stump for next series of passes. Lower and continue cutting.
- Continue in this manner until stump has been removed.
- Larger stumps may require repositioning machine to work at best advantages.
- IF RED LOW BATTERY LIGHT LIGHTS UP ON THE TRANSMITTER, THERE IS APPROXIMATELY 20 HOURS OF BATTERY POWER LEFT.



- Raise cutter wheel clear of stump and return to center position. On the radio control transmitter, put the Swing Brake switch in the LOCK position before moving or turning off the machine.
- Reduce engine speed to idle. DO NOT TURN OFF MOTOR. Engine must be allowed to cool slowly at idle for 3-5 minutes to avoid damage.
- With engine at idle (below 1100 RPM), disengage clutch by pushing the switch down on the radio control transmitter. The clutch will disengage immediately and the Clutch Engage light will go off on the clutch control panel. The cutter wheel will take several minutes to come to a complete stop.
- Move the machine away from the work area after the cutter wheel has come to a complete stop.
- Turn off machine using key on machine control panel. CLUTCH MUST BE DISENGAGED BEFORE TURNING MACHINE OFF. Allow cutter wheel to come to a complete stop before inspecting the work area.



DISENGAGE CLUTCH WITH ENGINE AT IDLE. CLUTCH MUST BE DISENGAGED BEFORE TURNING ENGINE OFF

SAFETY

- NEVER SERVICE A MACHINE WITH THE ENGINE RUNNING, SEVERE PERSONAL INJURY COULD OCCUR. TURN ENGINE OFF THEN REMOVE IGNITION KEY AND DISCONNECT POSITIVE BATTERY CABLE TO AVOID STARTING MACHINE ACCIDENTALLY.
 - CUTTER WHEEL MUST BE DISENGAGED BEFORE TURNING ENGINE ON/OFF AND BEFORE SERVICING A MACHINE. OTHERWISE SEVERE PERSONAL INJURY COULD OCCUR AS WELL AS MACHINE DAMAGE.
 - ALL MACHINE PARTS MUST COME TO A COMPLETE STOP AND HAVE TIME TO COOL COMPLETELY BEFORE SERVICING A MACHINE OR SEVERE INJURY COULD OCCUR, POSSIBLY SERIOUS BURNS AND/OR DISMEMBERMENT.
 - DO NOT OPERATE A MACHINE WITHOUT A COMPLETE NUMBER OF TEETH IN THE CUTTER WHEEL PROPERLY INSTALLED. EXCESSIVE MACHINE VIBRATION WILL OCCUR CAUSING PREMATURE BEARING FAILURE AND EQUIPMENT DAMAGE.
 - PLACE THE CUTTER WHEEL ON THE GROUND WHEN PERFORMING SERVICE ON A MACHINE.
-
- Check engine oil **daily** at dipstick, located inside the cover of the engine. **Engine must be level.** Boom in raised position will not affect the engine position; machine must be on level ground. Add recommended oil as required (see engine manual). Read engine manual and follow recommended schedule of periodic maintenance.
 - Replace the engine oil filter as required by the engine manufacturer. (See engine manual for more information.)
-
- Inspect the fuel/water separator **daily** and drain water regularly.

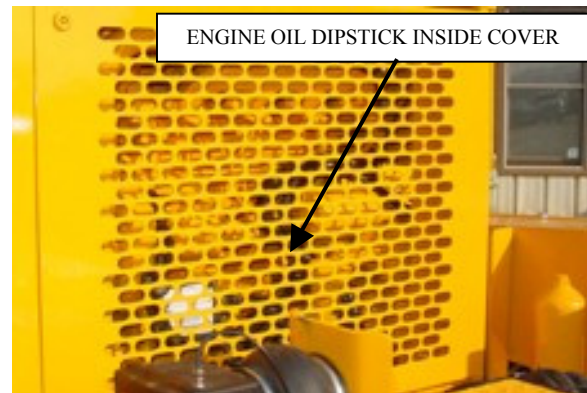

- The Hurricane track machine may come with an inline fuel filter. This filter must be changed every 50 hours of operation. Clamp the hoses on both sides of the filter and remove and replace with a new filter. Remove clamps before starting the machine. Fuel in the hose will spill out, clean any spilled fuel before operating the stump grinder.
- Inspect air filters **daily**. REPLACE, if necessary, WITH FACTORY AIR FILTERS ONLY. Do not blow out filters or tap filters on the ground. Replace the main filter when dirty. Replace inner safety filter when dirty or when the outer air filter has been changed 3 times. Follow engine manual procedure for removal and replacement. Do not allow dirt to get into engine when removing filters. Dirt ingestion will cause engine failure and is not warranted.



MAIN AIR FILTER

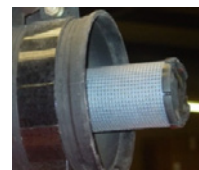

SAFETY AIR FILTER

Hurricane Track – Air Filters		
Engine HP	Part #	Air Filter
140 HP	09102443	Safety
140 HP	09102444	Main
175 HP	09102447	Safety
175 HP	09102446	Main
250 HP	09102447A	Safety
250 HP	09102447B	Main

- Check radiator coolant. See engine manual for additional coolant information.
- Radiator screen must be kept clear of debris, clean **daily**. Remove engine side cover and blow debris off radiator screen from the inside to the outside.



- Check hydraulic oil **daily** and replenish as necessary. A site glass is provided for easy viewing. If oil can be seen in glass, there is enough oil in the tank. Do not fill the tank more than 7/8 full; operating at high temperature will cause oil to expand and spill over if tank is full.
- The machine is equipped with Citgo AW32 hydraulic oil at time of manufacture; use same or equivalent.



- Inspect all guards, bolts, nuts and other parts **daily** for looseness and wear, repair as necessary.
- Inspect wiring harnesses for wear and replace if necessary.



- Check cutter wheel, pockets, and teeth for wear **daily**. If any repair is needed, see Servicing Cutter Wheel section for further instruction. **DO NOT** run machine without a complete set of teeth installed in cutter wheel.



- Check and tighten setscrews in cutter wheel bearing collars **weekly**.

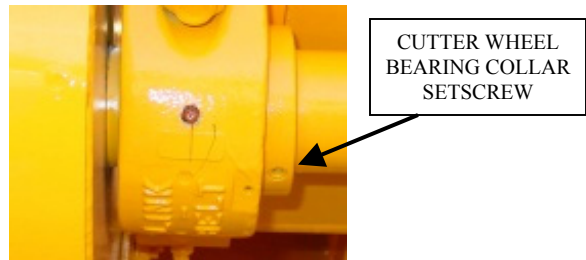

-
- Check and tighten setscrews in jackshaft and boom bearing collars **weekly**.

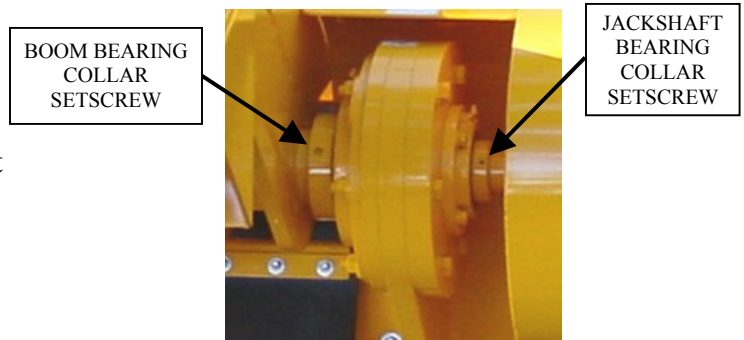

SAFETY

- NEVER SERVICE A MACHINE WITH THE ENGINE RUNNING, SEVERE PERSONAL INJURY COULD OCCUR. TURN ENGINE OFF THEN REMOVE IGNITION KEY AND DISCONNECT POSITIVE BATTERY CABLE TO AVOID STARTING MACHINE ACCIDENTALLY.
 - CUTTER WHEEL MUST BE DISENGAGED BEFORE TURNING ENGINE ON/OFF AND BEFORE SERVICING A MACHINE. OTHERWISE SEVERE PERSONAL INJURY COULD OCCUR AS WELL AS MACHINE DAMAGE.
 - ALL MACHINE PARTS MUST COME TO A COMPLETE STOP AND HAVE TIME TO COOL COMPLETELY BEFORE SERVICING A MACHINE OR SEVERE INJURY COULD OCCUR, POSSIBLY SERIOUS BURNS AND/OR DISMEMBERMENT.
 - DO NOT OPERATE A MACHINE WITHOUT A COMPLETE NUMBER OF TEETH IN THE CUTTER WHEEL PROPERLY INSTALLED. EXCESSIVE MACHINE VIBRATION WILL OCCUR CAUSING PREMATURE BEARING FAILURE AND EQUIPMENT DAMAGE.
 - PLACE THE CUTTER WHEEL ON THE GROUND WHEN PERFORMING SERVICE ON A MACHINE.
-
- Check engine oil **daily** at dipstick, located inside the cover of the engine. **Engine must be level.** Boom in raised position will not affect the engine position; machine must be on level ground. Add recommended oil as required (see engine manual). Read engine manual and follow recommended schedule of periodic maintenance.
 - Replace the engine oil filter as required by the engine manufacturer. (See engine manual for more information.)
-
- Inspect the fuel/water separator **daily** and drain water regularly.

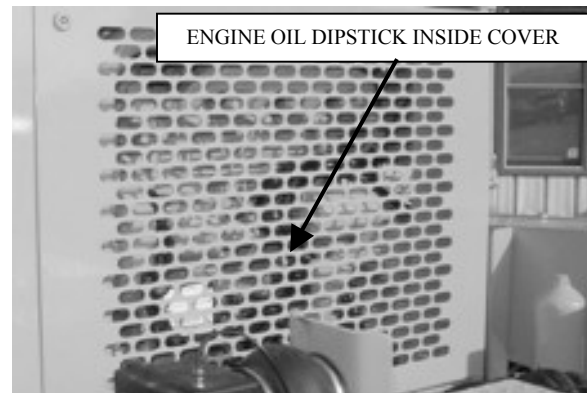

- The Hurricane track machine may come with an inline fuel filter. This filter must be changed every 50 hours of operation. Clamp the hoses on both sides of the filter and remove and replace with a new filter. Remove clamps before starting the machine. Fuel in the hose will spill out, clean any spilled fuel before operating the stump grinder.
- Inspect air filters **daily**. REPLACE, if necessary, WITH FACTORY AIR FILTERS ONLY. Do not blow out filters or tap filters on the ground. Replace the main filter when dirty. Replace inner safety filter when dirty or when the outer air filter has been changed 3 times. Follow engine manual procedure for removal and replacement. Do not allow dirt to get into engine when removing filters. Dirt ingestion will cause engine failure and is not warranted.

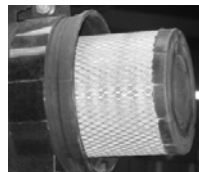

MAIN AIR FILTER

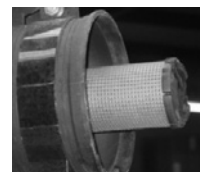

SAFETY AIR FILTER

Hurricane Track – Air Filters		
Engine HP	Part #	Air Filter
140 HP	09102442B	Safety
140 HP	09102442A	Main
175 HP	09102447	Safety
175 HP	09102446	Main
250 HP	09102447A	Safety
250 HP	09102447B	Main

- Check radiator coolant. See engine manual for additional coolant information.
- Radiator screen must be kept clear of debris, clean **daily**. Remove engine side cover and blow debris off radiator screen from the inside to the outside.



- Check hydraulic oil **daily** and replenish as necessary. A site glass is provided for easy viewing. If oil can be seen in glass, there is enough oil in the tank. Do not fill the tank more than 7/8 full; operating at high temperature will cause oil to expand and spill over if tank is full.
- The machine is equipped with Citgo AW32 hydraulic oil at time of manufacture; use same or equivalent.

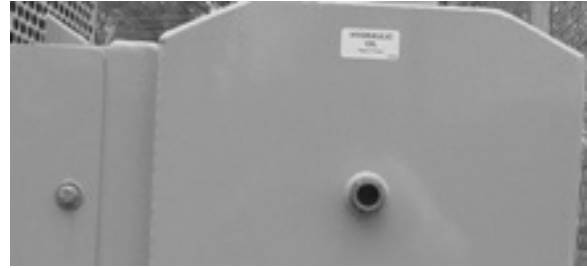

- Inspect all guards, bolts, nuts and other parts **daily** for looseness and wear, repair as necessary.
- Inspect wiring harnesses for wear and replace if necessary.



- Check cutter wheel, pockets, and teeth for wear **daily**. If any repair is needed, see Servicing Cutter Wheel section for further instruction. **DO NOT** run machine without a complete set of teeth installed in cutter wheel.



- Check and tighten setscrews in cutter wheel bearing collars **weekly**.

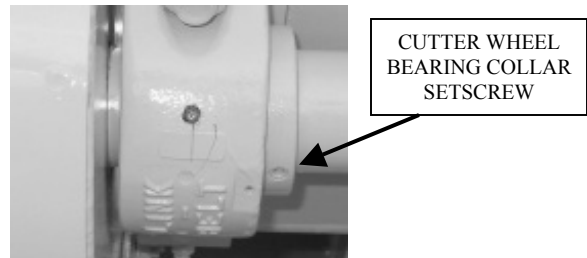

-
- Check and tighten setscrews in jackshaft and boom bearing collars **weekly**.

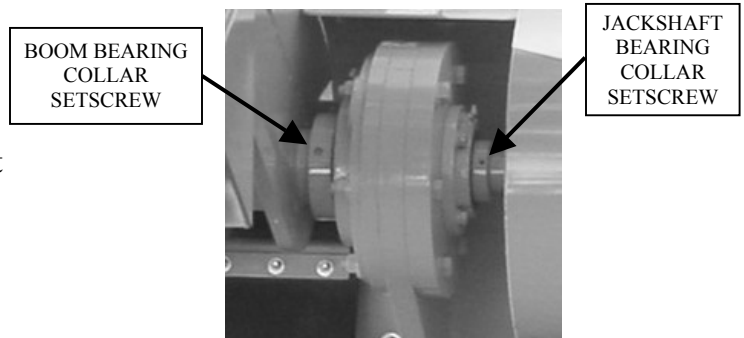

- The Hurricane track model, as well as all of our machines, is built to be a rugged performer. Your new machine is sturdy and our design goals are simplicity and reliability.
- A regularly scheduled maintenance program will pay big dividends in machine life, performance, and avoided downtime.

Lubrication Schedule

- Use **Texaco® Starplex II grease**.

CARLTON PROFESSIONAL TREE EQUIPMENT - HURRICANE TRACK	DAILY	WEEKLY	MONTHLY	2-3 Mon	6 Mon	Special Comments
- TRACK TENSIONING CYLINDER						See instructions in Track Maintenance section, DO NOT over grease tracks.
- BEARINGS						
- Pivot Table Bearing						Every 6 months or 100 Hours
- Swing Gear						See Servicing Bearings section or Track Maintenance section for lubrication.
- Boom Bearings						2-4 shots
- Jack Shaft Bearings						2-4 shots
- Cutter Wheel Bearings						Purge bearings daily
ENGINE REFER TO ENGINE MANUFACTURERS MANUAL FOR PROPER ENGINE SERVICING						

HTR-8 (AB/3/05)

COMPLAINT	CAUSE	CORRECTION
Engine will not start. (See Engine Manufacturer Manual for further information.)	<ul style="list-style-type: none"> • Loose ground wire. • Loose hot wire. • Dead battery. 	<ul style="list-style-type: none"> • Clean and tighten. • Clean and tighten. • Recharge or replace.
Belt Squeal.	<ul style="list-style-type: none"> • Belt tension too loose. • Belt out of line. 	<ul style="list-style-type: none"> • Tighten following the adjustment procedures in the Servicing Belts section. • Align Pulleys.
Cutter wheel vibration.	<ul style="list-style-type: none"> • Tooth missing. • Pocket out of balance. • Improper tooth arrangement. 	<ul style="list-style-type: none"> • Replace missing teeth. • Always replace pockets in pairs across from each other. • Install correctly with like pairs of teeth directly across from each other.
Cutter wheel throwing teeth.	<ul style="list-style-type: none"> • Bad pocket. • Dirt in pocket. • Worn cutter wheel. 	<ul style="list-style-type: none"> • Replace pocket. • Clean pocket and replace missing teeth. • Replace cutter wheel.
Cutter wheel breaking teeth.	<ul style="list-style-type: none"> • Teeth set too far out of pocket. 	<ul style="list-style-type: none"> • Use gauge to set teeth correctly.
Cutter wheel stops turning.	<ul style="list-style-type: none"> • Engine belt broke or tension too loose. • Poly chain® belt broke or tension too loose. • Sheared key in shaft. • Broken cutter wheel shaft. 	<ul style="list-style-type: none"> • Replace belt or adjust tension. See Servicing Belt section of this manual. • Replace belt or adjust tension. See Servicing Belt section of this manual. • Replace key. • Replace shaft.
Cutter head swings faster one way than the other or swings slow in both directions.	<ul style="list-style-type: none"> • Operator doesn't have good control of or understanding of switch operation. • The 50%/100% switch is on 100%. • Receiving intermittent signal. 	<ul style="list-style-type: none"> • The radio controls are proportional, meaning the more pressure you apply the more power the function gets for operation. • The swing function should only be operated at 50%. • Change radio frequency.
Cutter wheel won't engage	<ul style="list-style-type: none"> • PT Tech Clutch will not engage with engine at high RPM, check clutch panel for engine RPM too high indicator. 	<ul style="list-style-type: none"> • Lower engine RPM and try again. (Read PT Tech HPTO clutch manual provided at back of this manual.)

COMPLAINT	CAUSE	CORRECTION
Loss of oil pressure.	<ul style="list-style-type: none"> • Hose leaking oil. • Hydraulic oil level low. • Oil filters dirty or clogged. • Oil cooler has a leak. • Pressure switch wires loose or broken. • Pressure relief valve dirty. 	<ul style="list-style-type: none"> • Check all hoses for leaks using a board or cardboard. DO NOT use hand or finger. Replace hose as necessary. • Replenish tank. • Replace oil filter. • Check and repair. • Check and repair or replace wire if necessary. • See Servicing Hydraulics for cleaning the valve. • See PT Tech Manual provided in this manual for further information.
Power light goes out on PT Tech control panel.	<ul style="list-style-type: none"> • Bad fuse on wire. • Loose or broken wire. 	<ul style="list-style-type: none"> • Remove control panel cover, check and replace fuse. • Remove control panel cover and check wiring, repair if necessary. Read PT Tech HPTO manual for further information (provided at back of this manual.).
Roar in machine when cutter wheel is engaged.	<ul style="list-style-type: none"> • Belt guards or dust plates rubbing on jackshaft or cutter wheel shaft. • Jackshaft or cutter wheel bearings going bad. 	<ul style="list-style-type: none"> • Re-position away from shafts. • Contact your dealer or JP Carlton.
Bearing will not take grease.	<ul style="list-style-type: none"> • Grease fitting clogged. 	<ul style="list-style-type: none"> • Replace grease fitting
Track too loose.	<ul style="list-style-type: none"> • Tensioning cylinder too low on grease. DO NOT OVER GREASE TRACKS WILL BOW 	<ul style="list-style-type: none"> • See Track Maintenance section in this manual.
Traction loss of power.	<ul style="list-style-type: none"> • Hydraulic motor worn. 	<ul style="list-style-type: none"> • See Track Maintenance section in this manual. for information or contact your Carlton dealer.

ONLY USE QUALIFIED PERSONNEL TO WORK ON HYDRAULIC SYSTEMS FOR REPAIRS OR REPLACEMENT OF PARTS!!

Servicing Engine Belt

SAFETY

- **NEVER SERVICE A MACHINE WITH THE ENGINE RUNNING, SEVERE PERSONAL INJURY COULD OCCUR. TURN ENGINE OFF THEN REMOVE IGNITION KEY AND DISCONNECT POSITIVE BATTERY CABLE TO AVOID STARTING MACHINE ACCIDENTALLY.**
- **CUTTER WHEEL MUST BE DISENGAGED BEFORE TURNING ENGINE ON/OFF AND BEFORE SERVICING A MACHINE. OTHERWISE SEVERE PERSONAL INJURY COULD OCCUR AS WELL AS MACHINE DAMAGE.**
- **ALL MACHINE PARTS MUST COME TO A COMPLETE STOP AND HAVE TIME TO COOL COMPLETELY BEFORE SERVICING A MACHINE OR SEVERE INJURY COULD OCCUR, POSSIBLY SERIOUS BURNS AND/OR DISMEMBERMENT.**
- **PLACE THE CUTTER WHEEL ON THE GROUND WHEN PERFORMING SERVICE ON A MACHINE.**
- **DO NOT OPERATE A MACHINE WITHOUT A COMPLETE NUMBER OF TEETH IN THE CUTTER WHEEL PROPERLY INSTALLED. EXCESSIVE MACHINE VIBRATION WILL OCCUR CAUSING PREMATURE BEARING FAILURE AND EQUIPMENT DAMAGE.**

- Remove the engine belt guard covers. There are three sections for easier handling and 26 bolts hold the covers onto the guard.



- Loosen the four engine mounting bolts, two on each side of the engine. The bolts are attached with a large square nut under the mounting bracket so only one wrench is needed to loosen the bolts. DO NOT remove the bolts, just loosen enough to move engine.

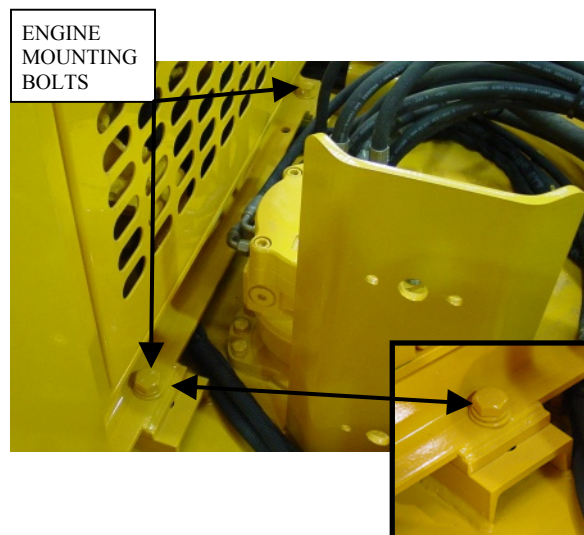

Servicing Engine Belt

- There is a dust protection plate, in two sections, that goes behind the engine sheave and bolts to the engine belt guard using four 1/4" bolts and nuts. Loosen all four bolts enough to be able to move the engine to loosen the belt and remove it.



LOOSEN NUTS ON DUST PROTECTION PLATE – 4 PLACES

- There are two adjustment bolts at the front of the machine attached to the engine mounting bolts. The jam nuts on these bolts are used to adjust belt tension by moving the engine.
- Loosen the jam nut on the outside of the plate on each adjustment bolt. Then turn the jam nut on the inside of the plate to move the engine back toward the cutter wheel to relieve pressure on the engine belt for removal. Turn one adjustment bolt's jam nut a small amount and then turn the other adjustment bolt's jam nut the same amount; working back and forth making adjustments until the engine has been moved enough to loosen the belt.

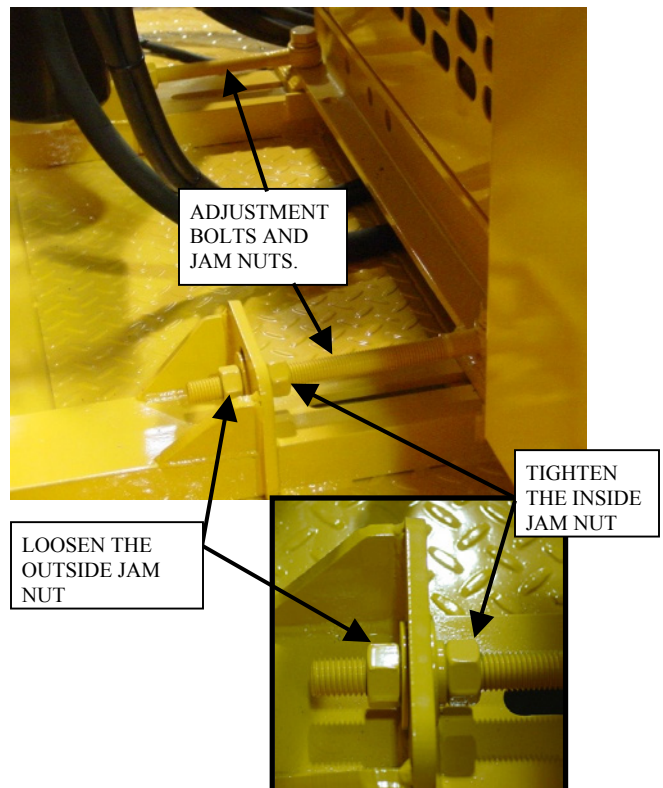

Servicing Engine Belt

- When the belt is loose enough, remove the belt by pulling it off the engine sheave and then the jackshaft sheave. Removing the belt from the engine sheave first should be easier because of the size of the sheave.
- Replace the engine belt.
- After replacing the engine belt, reposition the engine by loosening the inside jam nuts and then turning the outside jam nuts to pull the engine back into position. Turn one adjustment bolt's jam nut a small amount and then turn the other adjustment bolt's jam nut the same amount; working back and forth making adjustments until the engine has been moved enough to tighten the belt.

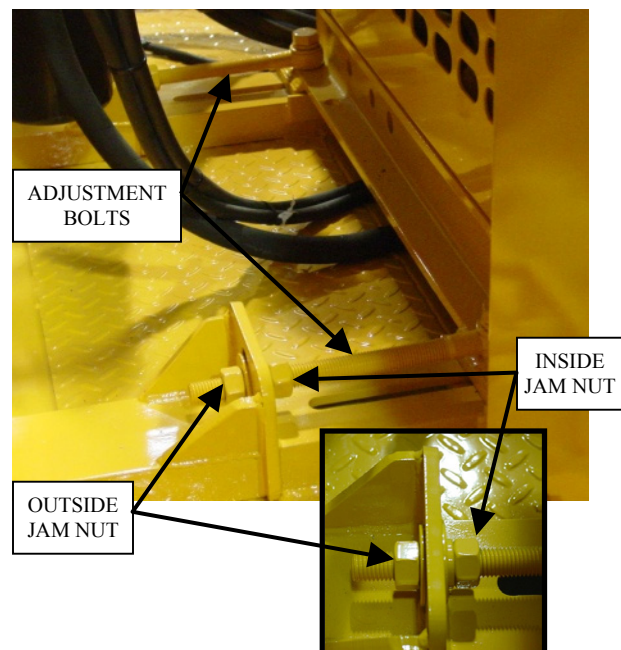

Servicing Engine Belt

- When the belt is tightened slightly, check the alignment of the sheaves using a straight edge. If sheaves are out of line, use the adjustment nuts to align the sheaves. You will need to loosen one adjustment bolt's jam nut and tighten the other, making only slight adjustments until the sheaves are aligned. When the sheaves are aligned, check the belt tension.
- The proper belt tension will depend on the size and number of belts supplied with the engine that is purchased with the Hurricane TRX. Refer to the chart below for the proper belt tension and the deflection force to be applied when checking the tension. If belt tension is too loose, tighten the adjustment bolt's jam nuts on the outside of the plate to increase belt tension. Turn one adjustment bolt's jam nut a small amount and then turn the other adjustment bolt's jam nut the same amount, working back and forth making adjustments and checking tension until belt tension is correct. If the belt tension is too tight, loosen the outside jam nuts and tighten the jam nuts on the inside of the plate. **DO NOT OVER TIGHTEN BELTS; OVERLY TIGHT BELTS WILL CAUSE BEARING AND ENGINE DAMAGE.**
- **NOTE:** Use the same procedure for making adjustments to worn belts that just need the tension adjusted. Remember to loosen all engine mount bolts and dust plate bolts as described for removing the belts.

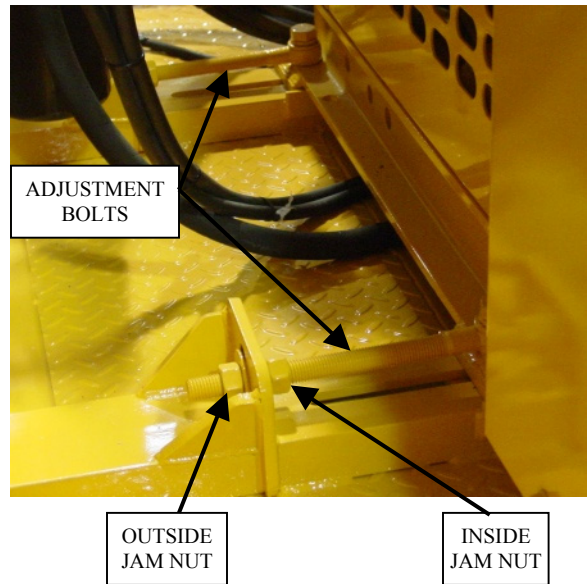

Engine HP	Belt	# of Belts (Grooves)	Deflection Force per Belt – New	Deflection Force per Belt – Used	Deflection
140 HP	B173	6	11.7 – 12.43 lb	10.23 – 10.97 lb	1”
140 HP	B195	8	11.7 – 12.43 lb	10.23 – 10.97 lb	1 1/8”
175 HP	B195	8	13.91 – 14.80 lb	12.12 – 13.01 lb	1 1/8”
250 HP	B195	8	18.63 – 19.86 lb	16.18 – 17.40 lb	1 1/8”

Servicing Engine Belt

- When belt tension is adjusted properly, tighten all four engine bolts (3/4") and torque bolts to 300 ft-lb. Next make sure all jam nuts on the adjustment bolts are tightened.

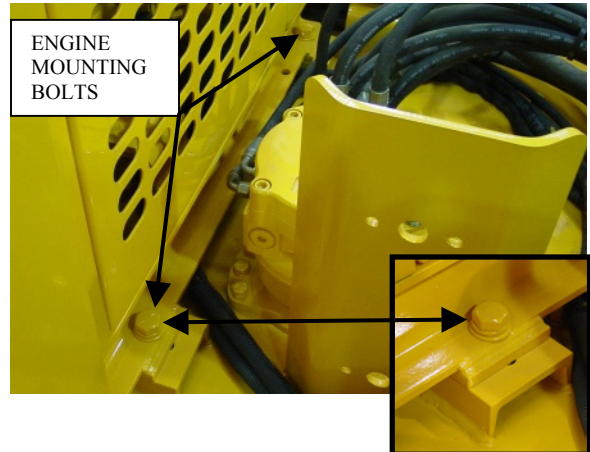

- Retighten the bolts on the dust protection plate that is behind the engine sheave and attached to the belt guard. Make sure the sections of the plate are pushed as close together as possible without rubbing the engine shaft to keep out as much debris as possible.



- Replace belt guard covers and tighten them securely. **NEVER run a machine without the guards and covers in place and secured properly, severe personal injury could occur.**



GENERAL TENSIONING OF V-BELT DRIVES

A few simple rules about tensioning will satisfy most of your requirements.

1. The best tension for the V-belt drive is the lowest tension at which the belt will not slip under the highest load condition.
2. Check the tension on a new belt frequently during the first day of operation.
3. Thereafter, check the belt tension periodically.
4. Too much tension shortens belt and bearing life.
5. Keep belts and sheaves free from any foreign material that may cause slippage.

Servicing Poly Chain® Belt

SAFETY

- **NEVER SERVICE A MACHINE WITH THE ENGINE RUNNING, SEVERE PERSONAL INJURY COULD OCCUR. TURN ENGINE OFF THEN REMOVE IGNITION KEY AND DISCONNECT POSITIVE BATTERY CABLE TO AVOID STARTING MACHINE ACCIDENTALLY.**
- **CUTTER WHEEL MUST BE DISENGAGED BEFORE TURNING ENGINE ON/OFF AND BEFORE SERVICING A MACHINE. OTHERWISE SEVERE PERSONAL INJURY COULD OCCUR AS WELL AS MACHINE DAMAGE.**
- **ALL MACHINE PARTS MUST COME TO A COMPLETE STOP AND HAVE TIME TO COOL COMPLETELY BEFORE SERVICING A MACHINE OR SEVERE INJURY COULD OCCUR, POSSIBLY SERIOUS BURNS AND/OR DISMEMBERMENT.**
- **PLACE THE CUTTER WHEEL ON THE GROUND WHEN PERFORMING SERVICE ON A MACHINE.**
- **DO NOT OPERATE A MACHINE WITHOUT A COMPLETE SET OF TEETH PROPERLY INSTALLED. EXCESSIVE MACHINE VIBRATION WILL OCCUR CAUSING PREMATURE BEARING FAILURE AND OTHER EQUIPMENT DAMAGE.**

Special care needs to be taken with your Poly Chain® belt. Alignment, tension, and cleanliness of this belt are very important. The Poly Chain® belt needs to be checked for tension every 70 to 100 hours of use. The Poly Chain® belt must be running true. If you adjust one bearing more than the other, the belt will run on an angle, which will cause belt failure. A belt broken straight across is the result of a shock load. In a shock load failure, the fibers are broken and over a period of time the belt will break down from the shock load and snap in half. A broken belt with lost teeth indicates that the belt was loose. When replacing the Poly Chain® belt, do not force the belt on over the sprockets; this can break the fibers.

- Remove the Poly Chain® belt guard cover. Remove all 14 bolts and washers in the belt guard cover and place them to the side for replacement. The belt guard cover is in two pieces for easier handling and removal.
- Loosen all the bolts and nuts in the belt guard. The nuts are easily accessible on the back of the guard.



Servicing Poly Chain® Belt

- Loosen the Poly Chain® belt by loosening the cutter wheel bearing bolts; DO NOT remove the bolts. There are two lock nuts on each bolt that have to be loosened to loosen the bearing bolts. MARK THE LOCATION OF EACH BEARING TO MAKE ADJUSTMENTS EASIER WHEN BELT IS REPLACED.
- There is a dust protection plate, in two sections, that goes behind the jackshaft sprocket and bolts to the Poly Chain® belt guard. The bolts on this plate must be loosened to be able to move the cutter wheel to loosen the belt and remove it.
- Loosen the nut closest to the cutter wheel bearing on the front jam bolts, loosen these nuts a good amount.
- Push the cutter wheel toward the engine as far as possible using the rear jam bolts; you need to loosen the nut closest to the bolt head on each rear jam bolt.
- To loosen the Poly Chain® belt, move the cutter wheel toward the front of the machine by turning the rear jam bolts on both bearings. Work back and forth alternately making small adjustments at a time. You will need to move the cutter wheel as far as the jam bolts will allow.
- Remove the cutter wheel sprocket. Place a mark on the cutter wheel shaft at the bushing before removing to line up when replacing the bushing and sprocket. Remove the three screws in the bushing and sprocket. Replace two of the screws in the two threaded holes to push the sprocket off the bushing. Turn the screws just a little at a time working back and forth from one to the other to keep from damaging the sprocket or bushing.

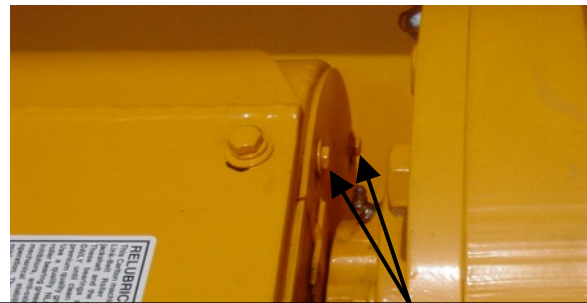
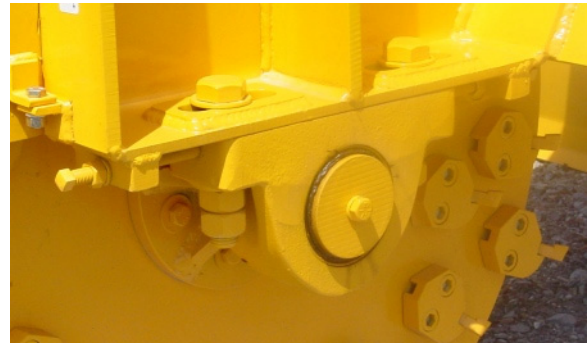

LOOSEN NUTS ON DUST PROTECTION PLATE – 4 PLACES

REAR JAM BOLT

FRONT JAM BOLT

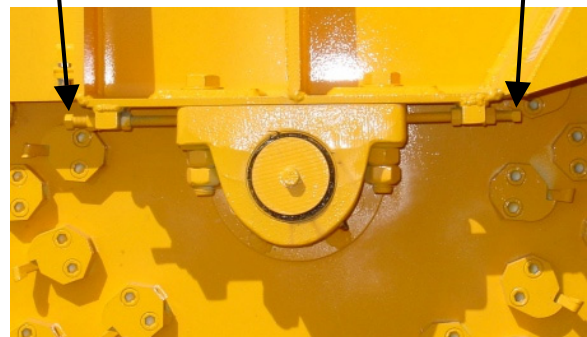

REMOVE 3 SCREWS FROM BUSHING AND SPROCKET

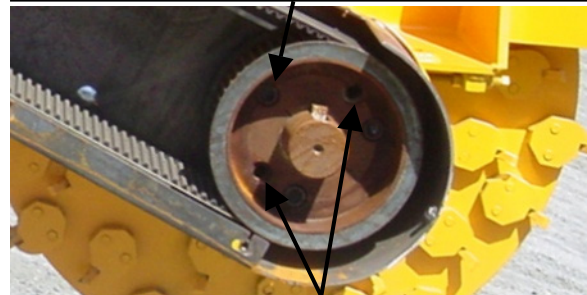

REPLACE 2 OF THE SCREWS IN THE THREADED HOLES TO PUSH THE SPROCKET OFF THE BUSHING

Servicing Poly Chain® Belt

- Remove the belt.
- Place the new belt on the jackshaft sprocket first and then put the cutter wheel sprocket in the belt and put it on the cutter wheel shaft. Replace the bushing in the sprocket and position it as close to the mark made earlier as possible. Replace the three screws and just get them started in each of the holes. Tighten the screws a little at a time working from one to another until the bushing is starting to get tight.
- Check the alignment of the sprockets using a straight edge and make adjustments as necessary. The belt will run at an angle and eventually break if the sprockets are not aligned.
- Adjust the alignment by moving the cutter wheel bushing in or out until the belt is aligned.
- When the belt is aligned tighten the screws in the cutter wheel sprocket and bushing all the way. Torque the screws to 195 ft. lbs.
- Reposition the cutter wheel by turning the rear jam bolts back to approximately their original position. Use a gage to measure between the cutter wheel bearing and the jam bolt on each side keeping them the same. Tighten both nuts on the rear jam bolts on each side of the mounting bracket as shown here.
- Then retighten the front jam bolts alternating from one to the other making small adjustments until the cutter wheel bearings are resting against the rear jam bolts.

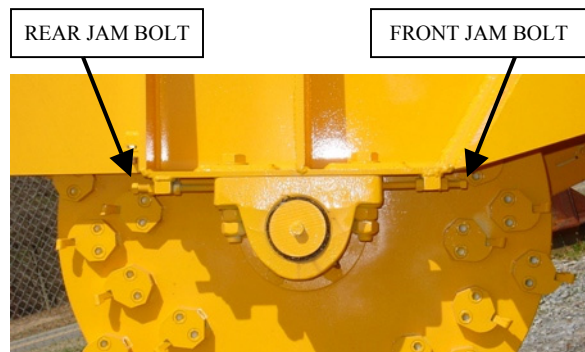

Servicing Poly Chain® Belt

- Check the Poly Chain® belt tension. See the chart that follows for tensioning specifications. If belt tension needs adjustment, use the jam bolts to move the cutter wheel to get the proper tension. Remember to make equal adjustments to both bearings to keep the sprockets aligned and the belt running true.
- **NOTE:** These instructions are also for making adjustments to worn belts that just need the tension adjusted. Cutter wheel bearing bolts and dust protection plate bolts have to be loosened to adjust belt tension. Then the jam bolts and nuts are used to adjust tension.
- When the belt is properly tensioned and the sprockets are aligned, tighten the nuts on the bearing bolts. There are two nuts on each bolt, make sure all nuts are tightened. Recheck tension and alignment to make sure nothing moved in tightening the cutter wheel bolts. If tension and alignment are still good, retighten any loose nuts on the jam bolts.
- Retighten the bolts on the dust protection plate that is behind the jackshaft sprocket and attached to the Poly Chain® belt guard. Make sure the sections of the plate are pushed as close together as possible without rubbing the jackshaft to keep out as much debris as possible.

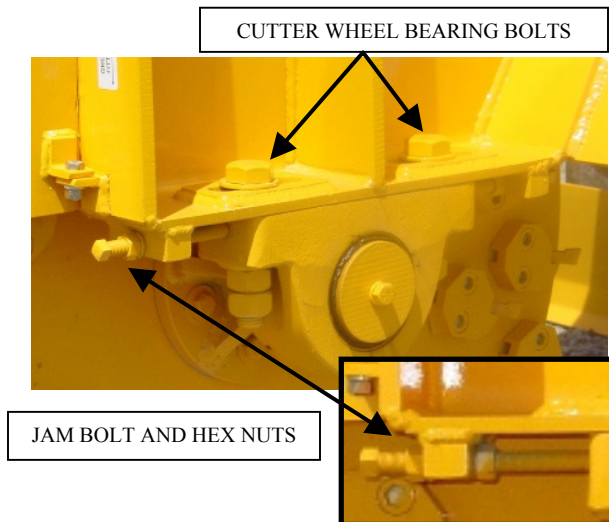

Servicing Poly Chain® Belt

- Retighten all the bolts and nuts in the belt guard. The nuts are easily accessible on the back of the guard.

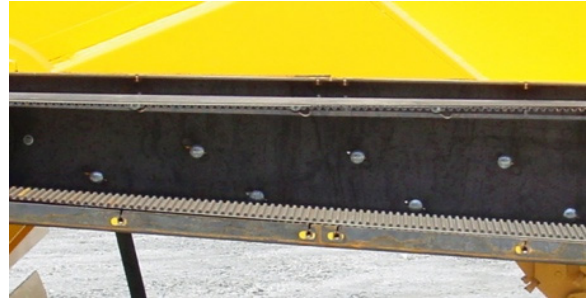

- Replace all 14 bolts with flat and lock washers. Tighten the bolts in the belt guard covers. **NEVER run a machine without the guards and covers in place and secured properly, severe personal injury could occur.**



POLY CHAIN® BELT TENSION

Engine HP	Engine Belt	Poly Chain® Belt	Deflection Force – New Belt	Deflection Force – Used Belt *	Deflection
140 HP	B173	14m-3136-125	127 – 137 lb	98 – 108 lb	3/4”
140 HP	B195	14m-3500-125	147 – 158 lb	112 – 124 lb	7/8”
175 HP	B195	14m-3500-125	178 – 192 lb	135 – 149 lb	7/8”
250 HP	B195	14m-3500-125	244 – 265 lb	184 – 204 lb	7/8”

* For used belts, the belt tension should be measured and recorded before removal so that the belt can be reinstalled at the same tension.

Always clean tip of grease gun fitting and grease fitting on machine before attaching hose to prevent dirt from being forced into machine parts. After applying grease, remove excess grease from the grease fitting to prevent dirt build up.

There are four (4) bearings on the jackshaft; two (2) mounted on the inside of the supports and two (2) mounted on the outside of the supports. These bearings should be greased daily to keep dirt and moisture out. Do not purge these bearings with grease. **PROPER MAINTENANCE IS CRITICAL TO ENSURE LONG BEARING LIFE.**



There are two (2) bearings on the cutter wheel shaft. These bearings should be purged until new grease is seen before and after every use, to keep dirt and moisture out. **PROPER MAINTENANCE IS CRITICAL TO ENSURE LONG BEARING LIFE.**



**** Your machine is lubed with Texaco® Starplex II grease when it is delivered from the factory. Starplex® II is lithium complex soap grease, which contains a specially formulated additive package to provide excellent rust protection, resistance to water washout, and extreme pressure properties. It is recommended as a multipurpose, high performance grease for severe duty industrial applications involving high temperatures, water contamination, and shock loading. Operating temperature range is from 450 F to -15 F.**

TURNTABLE BEARING

While turntable bearings require almost no attention, what little they are given will pay big dividends in long life, high performance, and trouble free service. Lubricate the bearing every 100 operating hours. When greasing the turntable bearing, lower the cutter wheel to the ground. Apply grease to the grease fitting shown at the right. Lift the cutter wheel off the ground, rotate the upper frame 90°, lower the cutter wheel, and apply grease again. Repeat this procedure until the upper frame has been rotated 360°, greasing the turntable bearing for a full rotation. Idle equipment should not be neglected. Grease dries out and “breathing” due to temperature changes can cause condensation within the bearing. Whether used or not, the bearing should have grease introduced every 6 months.

Be alert to changes in rotation, unusual sounds, and vibrations.

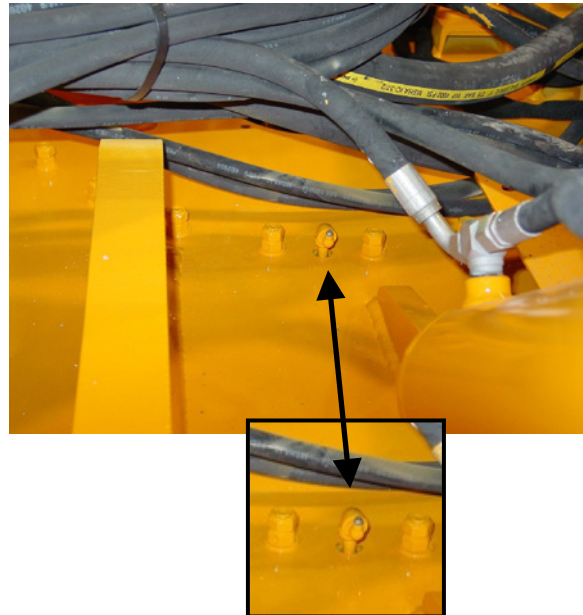

SWING GEAR

The swing gear needs to be greased every 100 hours of operation. When greasing the swing gear, lower the cutter wheel to the ground. Apply grease to the grease fitting shown at the right. Lift the cutter wheel off the ground, rotate the upper frame 90°, lower the cutter wheel, and apply grease again. Repeat this procedure until the upper frame has been rotated 360°, greasing the swing gear for a full rotation.

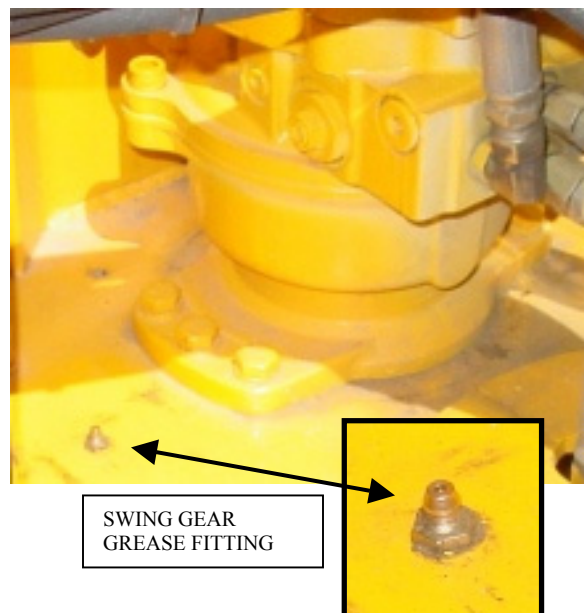

SAFETY

- NEVER SERVICE A MACHINE WITH THE ENGINE RUNNING, SEVERE PERSONAL INJURY COULD OCCUR. TURN ENGINE OFF THEN REMOVE IGNITION KEY AND DISCONNECT POSITIVE BATTERY CABLE TO AVOID STARTING MACHINE ACCIDENTALLY.
- CUTTER WHEEL MUST BE DISENGAGED BEFORE TURNING ENGINE ON/OFF AND BEFORE SERVICING A MACHINE. OTHERWISE SEVERE PERSONAL INJURY COULD OCCUR AS WELL AS MACHINE DAMAGE.
- ALL MACHINE PARTS MUST COME TO A COMPLETE STOP AND HAVE TIME TO COOL COMPLETELY BEFORE SERVICING A MACHINE OR SEVERE INJURY COULD OCCUR, POSSIBLY SERIOUS BURNS AND/OR DISMEMBERMENT.
- PLACE THE CUTTER WHEEL ON THE GROUND WHEN PERFORMING SERVICE ON A MACHINE.
- DO NOT OPERATE A MACHINE WITHOUT A COMPLETE NUMBER OF TEETH IN THE CUTTER WHEEL PROPERLY INSTALLED. EXCESSIVE MACHINE VIBRATION WILL OCCUR CAUSING PREMATURE BEARING FAILURE AND EQUIPMENT DAMAGE.

Machine	# of Teeth	Straight	Left	Right
Hurricane RS	48	2	23	23
Hurricane TRX	64	2	31	31

A locking pin is provided to hold cutter wheel in position during tooth removal and re-installation. Locking pin will only lock on outer teeth. NEVER PLACE HAND ON CUTTER WHEEL TO HOLD IN PLACE WHILE CHANGING TEETH. BE SURE TO REMOVE PIN BEFORE OPERATING STUMP GRINDER.

A Tooth Setting Gauge (P/N – 0450111) is provided with each machine for proper tooth installation. Line all teeth up with the inside edge of the groove in the gauge. Set ALL teeth to this edge with gauge against pocket, not against cutter wheel.



HURRICANE TRX IS SHOWN ABOVE



TOOTH ARRANGEMENT

- Inspect pockets, teeth and bolts for damage and replace as required.
- When replacing pockets, always replace new pockets across from each other in order to prevent vibration.
- Replacement teeth must be carbide tipped and have like design as provided with the machine.
- Use anti-seize on threads to prevent bolts from “freezing up” in cutter wheel pockets.
- When replacing complete set of teeth, be sure to duplicate original factory tooth arrangement.
- Torque bolts to 150 ft. lbs.

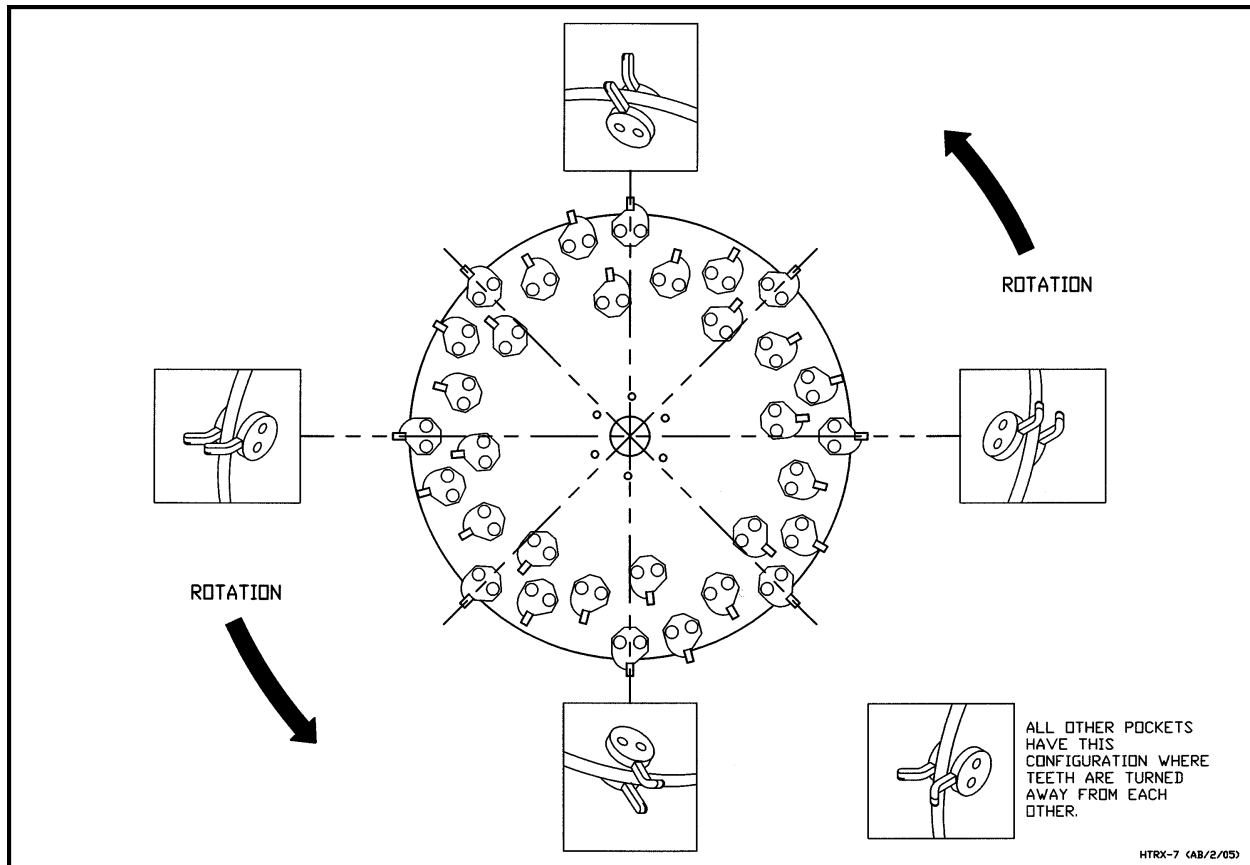

opposing outside pockets carry like arrangements of teeth to cancel vibration (Hurricane TRX tooth pattern shown above)

- Straight teeth are mounted in TWO OPPOSING OUTSIDE POCKETS.
- A straight tooth must have a 45° tooth accompanying it in the same pocket set. The opposite pocket set should have this same combination of straight and 45° teeth, except with positions reversed. Mounting these teeth opposite each other on the cutter wheel cancels damaging vibration.
- Two Remaining Outside Pockets must have 45° teeth overlapping the centerline of the wheel to make plunge cuts possible. Mount two left 45° teeth opposite two right 45° teeth.
- All remaining pockets require 45° teeth mounted away from the wheel.
- Always make sure the carbide tip is facing the rotation direction of the cutter wheel.

Hurricane RS

OPTIONAL:

Sandvik® Dura Disk II Cutter Wheel

THE PICTURES SHOWN BELOW ARE FOR A DIFFERENT MACHINE BUT THE WHEEL CONFIGURATION IS THE SAME.

- If the Hurricane RS is supplied with the optional Dura Disk II cutter wheel, there are sixty-eight (68) teeth to a complete set. There are twelve (12) Short Plow Bolt Bits (Carlton part #0450121) and fifty-six (56) Plow Bolt Bits (Carlton part #0450120).
- **DO NOT OPERATE A MACHINE WITHOUT A COMPLETE NUMBER OF TEETH IN THE CUTTER WHEEL PROPERLY INSTALLED. EXCESSIVE MACHINE VIBRATION WILL OCCUR CAUSING PREMATURE BEARING FAILURE AND EQUIPMENT DAMAGE.**
- A locking pin is provided to hold cutter wheel in position during tooth removal and re-installation.
- The locking pin will only lock in the deep slots of the outer teeth. Line the slot up with the locking pin slot and insert the pin to lock position. The pin will need to be removed and reinserted as wheel is rotated to change remaining teeth.
- **NEVER PLACE YOUR HAND ON THE CUTTER WHEEL TO HOLD IT IN PLACE WHILE CHANGING TEETH.**
- **BE SURE TO REMOVE THE PIN BEFORE OPERATING THE STUMP CUTTER.**
- The teeth do not require a setting gauge. The only requirement is to be installed in the proper direction and tightened to the proper torque as discussed in the next section.
- **When replacing a cutter wheel tooth, replace the tooth and nut as a set and use anti-seize on the threads.**



TOOTH ARRANGEMENT

- Inspect pockets, teeth and bolts for damage and replace as required.
- When replacing a cutter wheel tooth, replace the tooth and nut as a set and use anti-seize on the threads.
- When replacing teeth and pockets, also replace the teeth and pockets across from each other diagonally in order to maintain wheel balance and prevent vibration.
- All teeth and pockets are of a specific design and must be replaced with original manufacturer's replacement parts. Replacement teeth must be carbide tipped.
- When replacing complete set of teeth, be sure to duplicate original factory tooth arrangement. SEE DIAGRAM BELOW.
- The seating surfaces of the tooth and pocket are formed, but make sure the tooth is inserted with the carbide facing the direction of rotation.
- The pictured view is the engraved side of the wheel. The wheel is engraved with outside pocket numbers, outside pocket angle/direction (20 R or 20 L), and wheel rotation. (The engraved side of wheel is marked left side of wheel; this is for manufacturing purposes only. It does not refer to the left side of the machine as described in the General Information section.)
- Outside pocket teeth are Short Plow Bolt Bits. These pockets are angled and welded in place. You can switch teeth from one outside pocket to a pocket that is the opposite direction to prolong tooth life, such as switching a tooth from a 20 R with a tooth from a 20 L pocket. The cutting edge is the corner and this will turn the opposite corner out for use.
- These teeth are tightened with a Stover Lock Nut. Torque on Stover locking nuts is not to exceed 270 ft/lbs.
- All teeth on cutter wheel sides are Plow Bolt Bits. When changing these teeth you must remove both teeth in the same pocket, one on each side of the wheel. When the nuts are torqued, the pocket is jammed and the teeth can only be removed this way.
- These teeth are tightened with a Locking Jam Nut. Torque on locking jam nuts is not to exceed 128 ft/lbs.
- The pocket will receive wear when cutting and can be switched from one side of the cutter wheel to the other to prolong life. Remember the teeth must be replaced in the original position on each side of the wheel.

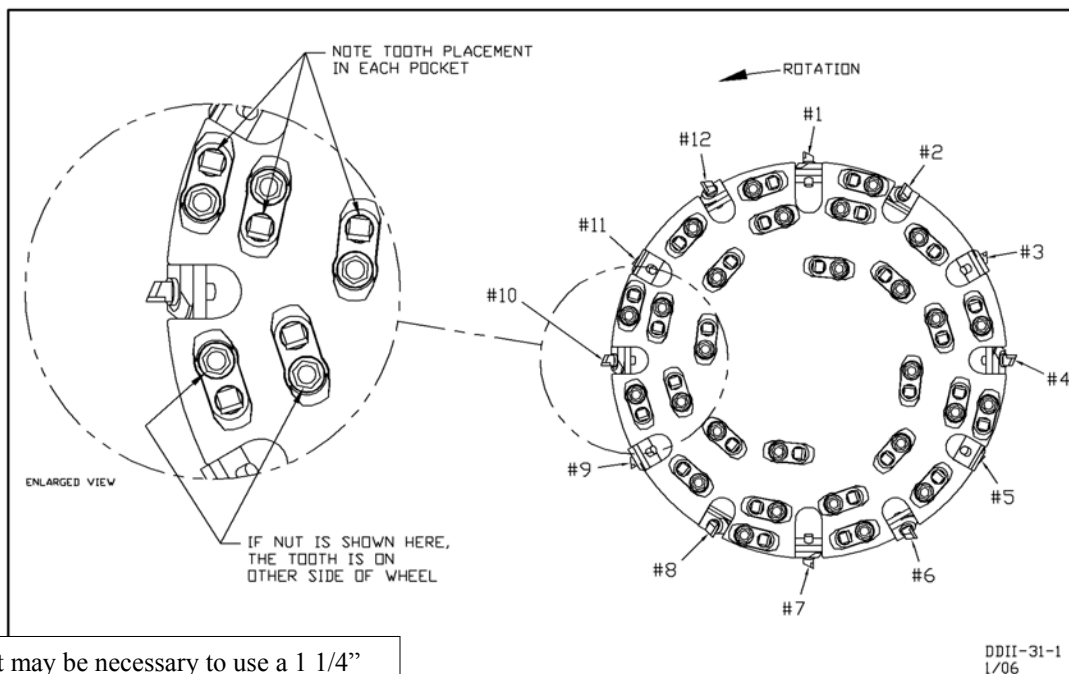

It may be necessary to use a 1 1/4" hole saw to remove debris around nut to make tooth removal easier.

DDII-31-1
1/06

Hurricane *TRX*

OPTIONAL:

Sandvik® Dura Disk II Cutter Wheel

- If the Hurricane *TRX* is supplied with the optional Dura Disk II cutter wheel, there are one hundred four (104) teeth to a complete set. There are sixteen (16) Short Plow Bolt Bits (Carlton part #0450121) and eighty-eight (88) Plow Bolt Bits (Carlton part #0450120).
- **DO NOT OPERATE A MACHINE WITHOUT A COMPLETE NUMBER OF TEETH IN THE CUTTER WHEEL PROPERLY INSTALLED. EXCESSIVE MACHINE VIBRATION WILL OCCUR CAUSING PREMATURE BEARING FAILURE AND EQUIPMENT DAMAGE.**
- A locking pin is provided to hold cutter wheel in position during tooth removal and re-installation.
- The locking pin will only lock in the deep slots of the outer teeth. Line the slot up with the locking pin slot and insert the pin to lock position. The pin will need to be removed and reinserted as wheel is rotated to change remaining teeth.
- **NEVER PLACE YOUR HAND ON THE CUTTER WHEEL TO HOLD IT IN PLACE WHILE CHANGING TEETH.**
- **BE SURE TO REMOVE THE PIN BEFORE OPERATING THE STUMP CUTTER.**
- The teeth do not require a setting gauge. The only requirement is to be installed in the proper direction and tightened to the proper torque as discussed in the next section.
- **When replacing a cutter wheel tooth, replace the tooth and nut as a set and use anti-seize on the threads.**



TOOTH ARRANGEMENT

- Inspect pockets, teeth and bolts for damage and replace as required.
- When replacing a cutter wheel tooth, replace the tooth and nut as a set and use anti-seize on the threads.
- When replacing teeth and pockets, also replace the teeth and pockets across from each other diagonally in order to maintain wheel balance and prevent vibration.
- All teeth and pockets are of a specific design and must be replaced with original manufacturer's replacement parts. Replacement teeth must be carbide tipped.
- When replacing complete set of teeth, be sure to duplicate original factory tooth arrangement. SEE DIAGRAM BELOW.
- The seating surfaces of the tooth and pocket are formed, but make sure the tooth is inserted with the carbide facing the direction of rotation.
- The pictured view is the engraved side of the wheel. The wheel is engraved with outside pocket numbers, outside pocket angle/direction (20 R or 20 L), and wheel rotation. (The engraved side of wheel is marked left side of wheel; this is for manufacturing purposes only. It does not refer to the left side of the machine as described in the General Information section.)
- Outside pocket teeth are Short Plow Bolt Bits. These pockets are angled and welded in place. You can switch teeth from one outside pocket to a pocket that is the opposite direction to prolong tooth life, such as switching a tooth from a 20 R with a tooth from a 20 L pocket. The cutting edge is the corner and this will turn the opposite corner out for use.
- These teeth are tightened with a Stover Lock Nut. Torque on Stover locking nuts is not to exceed 270 ft/lbs.
- All teeth on cutter wheel sides are Plow Bolt Bits. When changing these teeth you must remove both teeth in the same pocket, one on each side of the wheel. When the nuts are torqued, the pocket is jammed and the teeth can only be removed this way.
- These teeth are tightened with a Locking Jam Nut. Torque on locking jam nuts is not to exceed 128 ft/lbs.
- The pocket will receive wear when cutting and can be switched from one side of the cutter wheel to the other to prolong life. Remember the teeth must be replaced in the original position on each side of the wheel.

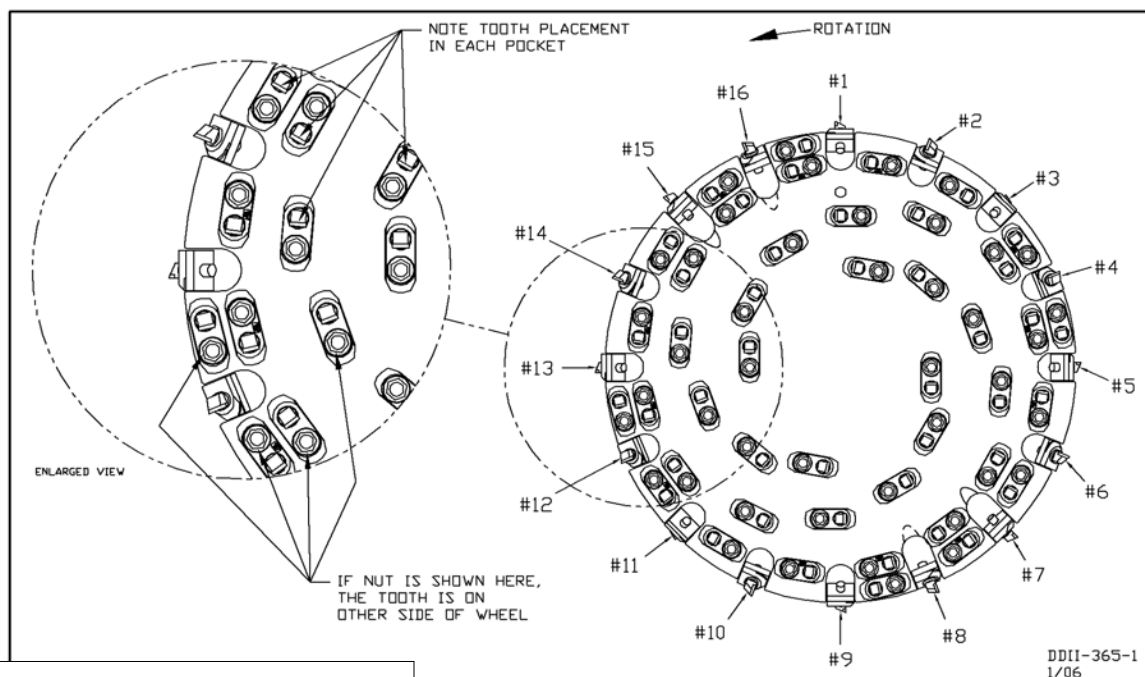

It may be necessary to use a 1 1/4" hole saw to remove debris around nut to make tooth removal easier.

TOOTH SHARPENING

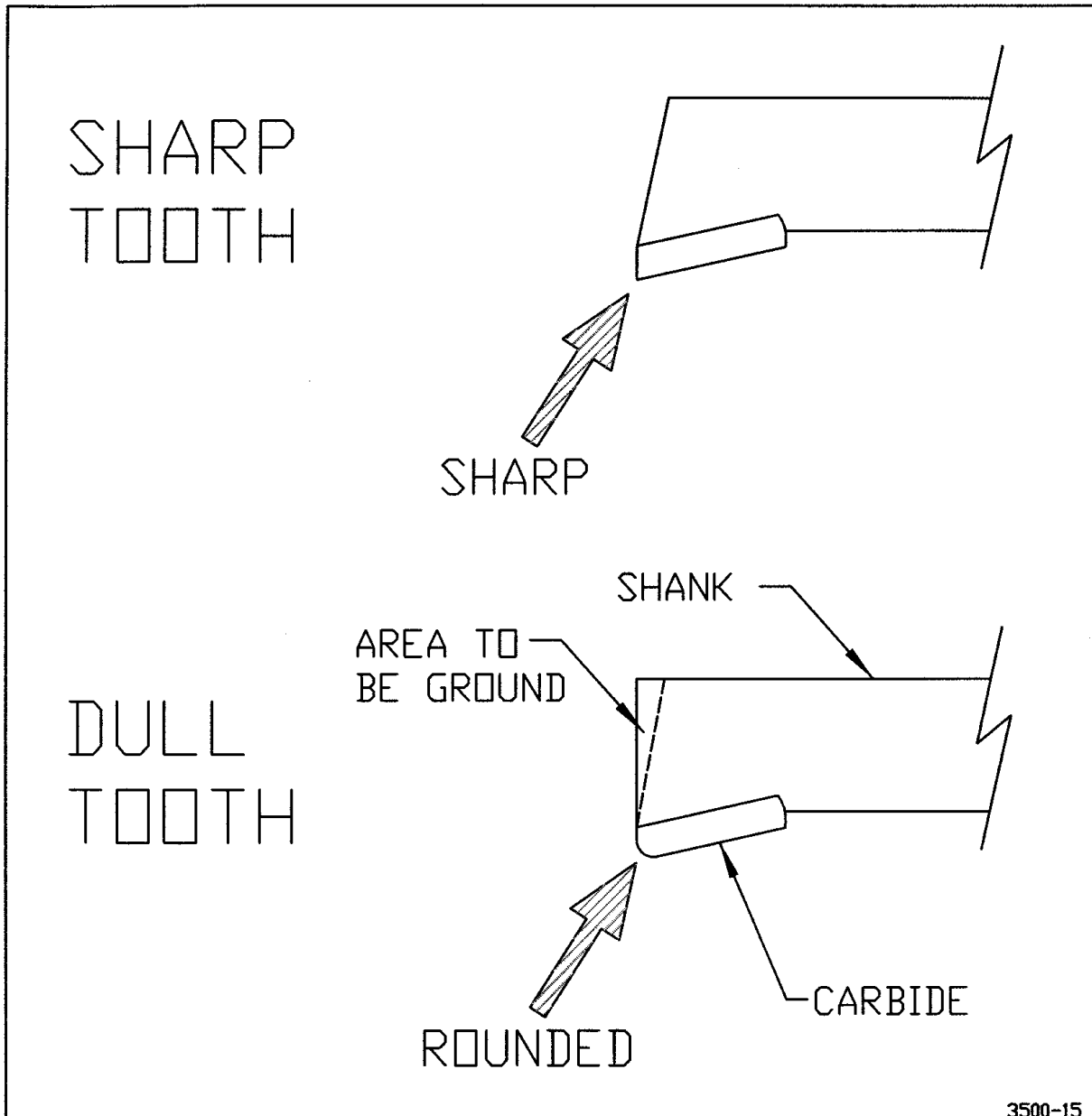

Begin by chamfering shank back past edge of carbide. You do this because if it is not back far enough the shank will hit the stump and not the carbide, thus causing a lot of vibration. Once the shank is angled far enough back, then begin sharpening carbide.

Cut shank with a standard rock and cut the carbide with a silicone carbide or diamond rock.

CAUTION: GRINDING CARBIDE CAN BE A HEALTH HAZARD. Use facemask to prevent breathing in harmful material while grinding.

SAFETY

- **NEVER SERVICE A MACHINE WITH THE ENGINE RUNNING, SEVERE PERSONAL INJURY COULD OCCUR. TURN ENGINE OFF THEN REMOVE IGNITION KEY AND DISCONNECT POSITIVE BATTERY CABLE TO AVOID STARTING MACHINE ACCIDENTALLY.**
- **CUTTER WHEEL MUST BE DISENGAGED BEFORE TURNING ENGINE ON/OFF AND BEFORE SERVICING A MACHINE. OTHERWISE SEVERE PERSONAL INJURY COULD OCCUR AS WELL AS MACHINE DAMAGE.**
- **ALL MACHINE PARTS MUST COME TO A COMPLETE STOP AND HAVE TIME TO COOL COMPLETELY BEFORE SERVICING A MACHINE OR SEVERE INJURY COULD OCCUR, POSSIBLY SERIOUS BURNS AND/OR DISMEMBERMENT.**
- **DO NOT OPERATE A MACHINE WITHOUT A COMPLETE NUMBER OF TEETH IN THE CUTTER WHEEL PROPERLY INSTALLED. EXCESSIVE MACHINE VIBRATION WILL OCCUR CAUSING PREMATURE BEARING FAILURE AND EQUIPMENT DAMAGE.**
- **PLACE THE CUTTER WHEEL ON THE GROUND WHEN PERFORMING SERVICE ON A MACHINE.**

ONLY USE QUALIFIED PERSONNEL TO WORK ON HYDRAULIC SYSTEMS FOR REPAIRS OR REPLACEMENT OF PARTS!!

WARNING:

- **RELEASE HYDRAULIC PRESSURE BEFORE PERFORMING ANY SERVICE TO HYDRAULIC LINES OR OTHER COMPONENTS.**
 - **FLUID UNDER PRESSURE CAN PENETRATE THE SKIN AND CAUSE SEVERE INJURY. SEEK IMMEDIATE MEDICAL ATTENTION IF SKIN IS PENETRATED. CHECK HOSES AND FITTINGS USING A BOARD OR CARDBOARD; DO NOT USE HAND OR FINGER. ALWAYS WEAR EYE PROTECTION.**
- Check hydraulic oil **daily**, with engine off and cool, and replenish as necessary. A site glass is provided for easy viewing. If oil can be seen in glass, there is enough oil in the tank. Do not fill the tank more than 7/8 full; operating at high temperature will cause oil to expand and spill over if tank is full.
 - The machine is equipped with Citgo AW32 hydraulic oil at time of manufacture; use same or equivalent.
 - Drain and replace hydraulic oil after the first 100 hours of operation and then every 500 hours thereafter. Discard used oil properly.



- There are three hydraulic filters on the Hurricane track machine. Two are return filters and the other is a high-pressure line filter. Replace all hydraulic filters after the first 50 hours of operation for a new machine. Thereafter, replace all filters every 200 hours of operation.
- Unscrew the old filters and O-rings on the return lines and discard properly. Replace with new filters and new O-rings. Screw in filters hand tight only. Recheck oil level and refill if needed, as described above.
- For machines equipped with the high-pressure filter at the right, cover the machine around the filter before removing the cover to replace the filter. When the cover is removed, oil in the container will spill out on the machine.
- Loosen the nut at the top of the filter unit. Remove the cover. Remove the old filter and discard properly. Replace with new filter.
- Clean up all oil that is spilled before running the machine to prevent a fire hazard.

OR

- For machines equipped with the high-pressure line filter at the right, remove the plate on the top by unscrewing it. Then lift the old filter out and discard properly. This design will eliminate most of the oil spilling but some may drip from the filter. Clean up any spilled oil to prevent fire hazard.
- Replace with new filter, use only manufacturer recommended filter. Contact JP Carlton or your local dealer

HYDRAULIC RETURN LINE FILTERS

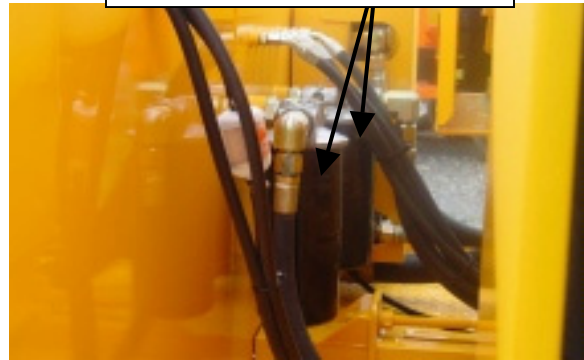

HYDRAULIC HIGH-PRESSURE LINE FILTER



- Inspect hydraulic hoses and fittings daily for leaks, tightness, wear, or damage. Repair or replace as needed.
- FLUID UNDER PRESSURE CAN PENETRATE THE SKIN AND CAUSE SEVERE INJURY. CHECK HOSES AND FITTINGS USING A BOARD OR CARDBOARD; DO NOT USE HAND OR FINGER. SEEK IMMEDIATE MEDICAL ATTENTION IF SKIN IS PENETRATED. ALWAYS WEAR EYE PROTECTION.



READ PT TECH HPTO MANUALS FOR COMPLETE SERVICE INFORMATION.

- The PT Tech HPTO requires simple routine service by maintaining the proper oil level in the hydraulic tank and by replacing the oil filter when required as described above. It is imperative to check the hydraulic oil level daily and replenish as needed. The oil must be checked with the clutch disengaged and the engine off in a cooled condition to get a true oil level reading, as heat will cause the oil to expand.
- Every 500 hours of operation check all HPTO bolted connections and hydraulic connections.
- The HPTO must be inspected and serviced after 5000 hours of operation. Read the PT Tech manual for more information.
- The PT Tech HPTO manifold has a pressure relief valve located on the right side of the manifold. The pressure relief valve should be removed every 100 hours of operation and cleaned with pressurized air. Remove the relief valve using a 7/8" wrench and clean the end of the valve with pressurized air. At the same time, clean the hole in the manifold using pressurized air blowing inside the hole.

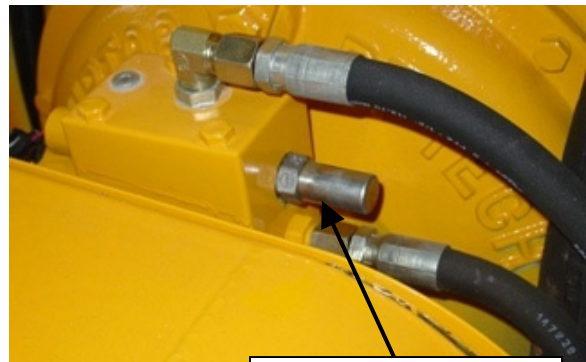

PRESSURE RELIEF VALVE

HURRICANE TRX MACHINE WIRING DIAGRAM

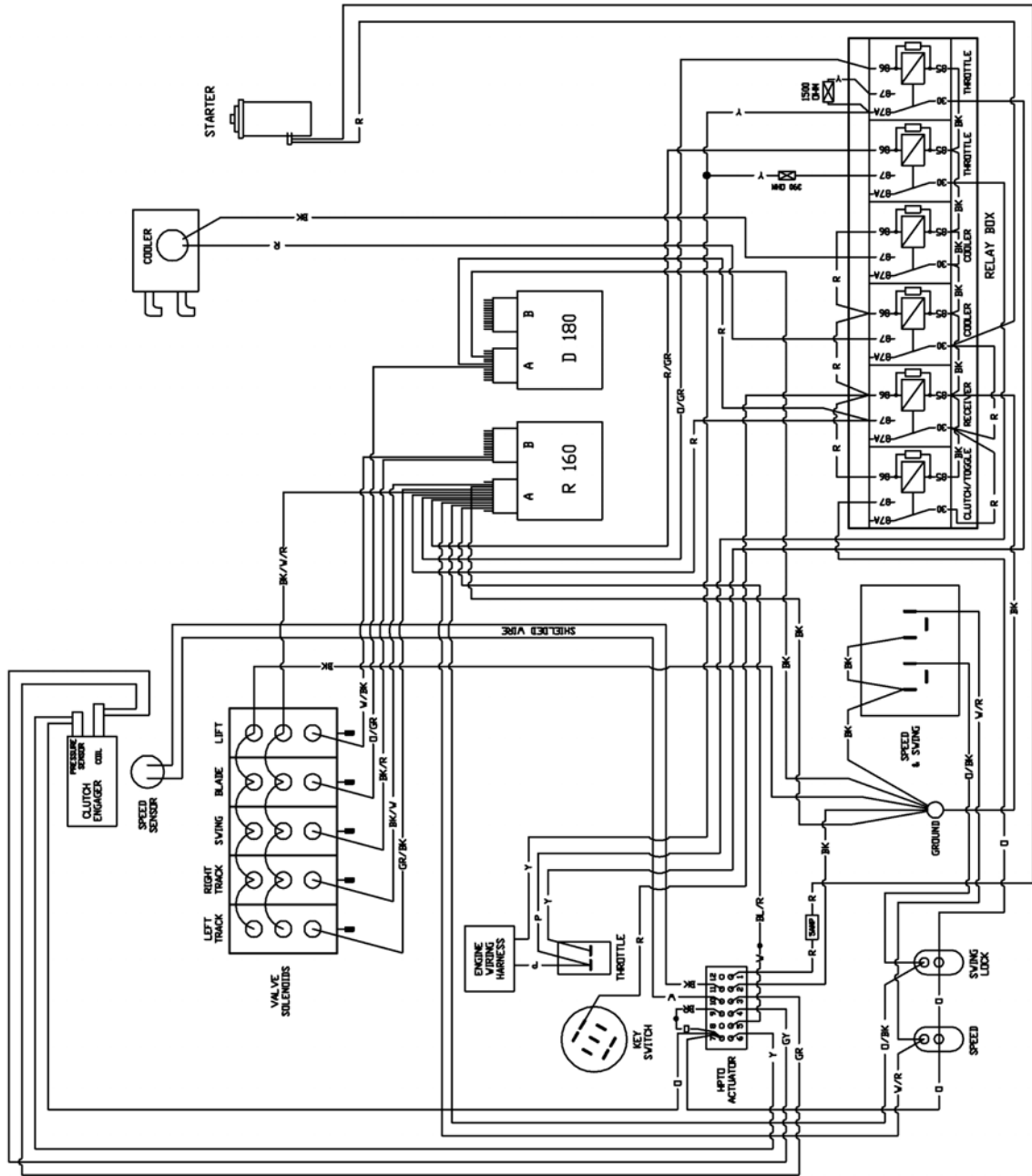

STARTING SERIAL # 776

ACTUAL RELAY CONNECTIONS	COLOR CODES
R	RED
D	ORANGE
PR	PURPLE
GY	GRAY
BL	BLACK
BR	BROWN
W	WHITE
R/BK	RED/BLACK
B/WBK	BROWN/BLACK
Y/R	YELLOW/RED
O/R	ORANGE/RED
B/R	BLACK/RED
BR/BK	BROWN/BLACK
BL/Y	BLACK/YELLOW
BL/BL	BLACK/BLACK
BL/GR	BLACK/GRAY
BR/GR	BROWN/GRAY
BL/BR	BLACK/BROWN

66101-E - WIRE FROM VALVE SOLENOID TO STARTER WAS BLACK & #9 WAS D1. WIRES FROM SWING/SPEED BLOCK WERE D/BK, WIRE FROM SWING LOCK WAS 1/2 BK WIRE FROM SWING/SPEED BLOCK TO SPEED WAS R/BK, 1/2 R AND 1/2 BK WIRE FROM SWING LOCK TO COOLER & SWING LOCK CORRECTED BLUE WIRE FROM COOLER & #2 GRD WIRE FROM HPTO.

66072-B - ADDED RELAY FOR CLUTCH/ HPTO. 1 RED WIRE TO STARTER, JUMP WIRE ON RELAYS #86 WERE BK, JUMP Labeled RELAYS.

66050-C - REPLACED OLD CONNECTOR AND VALVE SOLENOID WITH NEW REMOTE SOLENOID. PARTS # 66070/680 AND VALVE SOLENOID.

WARRANTY REPAIRS THE 16-PIN CONNECTOR RESOLUTION. NEWER WIRE # 18 & 20 SWITCHED WIRE AND LOCATION ON SOLENOIDS FOR WIRES 9, 9, 10, & 11.

Carlton
PROFESSIONAL
TREE EQUIPMENT

CHECKED BY: _____
HTRX-11E CURRENT CAB/10/11/06J

Hurricane RS

ITEM NO	PART NO	DESCRIPTION	QTY
1	19040079	Weldment, Engine Belt Base	1
2		1/2"-13 x 1 1/2" Carriage Bolt	9
3	0150304	1/2" Flat Washer	9
4	0150206	1/2"-13 Lock Nut	9
5	0400121B	V-Belt – 6/B173	6
6	0250109	Engine Sheave – 6B8.0 SF	1
7	0250182B	Tapered Bushing – SF x 2 1/8	1
8	0250127	Tapered Bushing – SF x 2 7/16	1
9	0250186	Jackshaft Sheave – 6B18.4 SF	1
10		Key – 3/4" Square x 4"	1
11		Key – 5/8" x 1/2" x 2"	1
12	19040080	Assembly, Engine Belt Guard (1 unit – 2 pieces)	1
13		3/8"-16 x 1" HH Bolt	14
14	0150404	3/8" Lock Washer	14
15	0150303	3/8" Flat Washer	14
16	0150119B	3/8" Hex Nut (welded inside #19040073)	14
17	19040082	Plate, Dust, Engine Belt Base (1 unit – 2 pieces)	1
18		1/4"-20 x 1 1/2" HH Bolt	4
19		1/4" Flat Washer	8
20	0150218	1/4"-20 Lock Nut	4

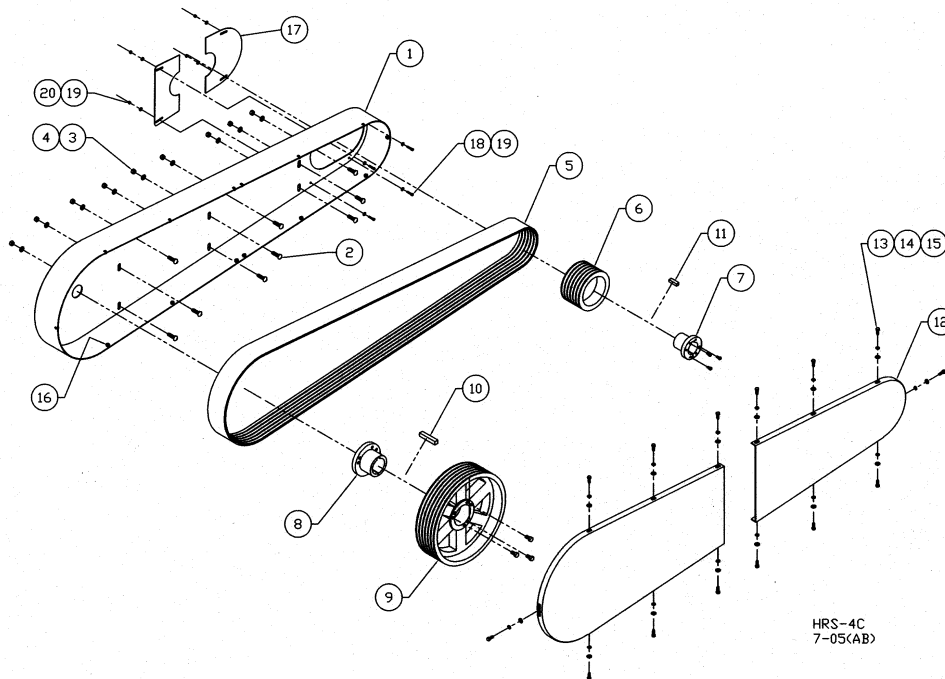

Items # 12 & # 17 are manufactured as 1 piece and sheared into sections for a tight fit. Each item is sold as a single unit, not individual pieces.

Hurricane TRX

ITEM NO	PART NO	DESCRIPTION	QTY
1	19040073	Weldment, Engine Belt Base	1
2		1/2"-13 x 1 1/2" Carriage Bolt	14
3	0150304	1/2" Flat Washer	14
4	0150206	1/2"-13 Lock Nut	14
5	0400121A	V-Belt – 8RB195	1
6	0250185	Engine Sheave – 8B6.8 SF	1
7	0250182A	Tapered Bushing – SF x 2 1/2	1
8	0250125A	Tapered Bushing – F x 3 3/16	1
9	0250148	Jackshaft Sheave – 8B18.4 F	1
10		Key – 3/4" Square x 4"	1
11		Key – 5/8" x 1/2" x 2"	1
12	19040074	Assembly, Engine Belt Guard (1 unit – 3 pieces)	1
13		3/8"-16 x 1" HH Bolt	26
14	0150404	3/8" Lock Washer	26
15	0150303	3/8" Flat Washer	26
16	0150119B	3/8" Hex Nut (welded inside #19040073)	26
17	19040076	Plate, Dust, Engine Belt Base (1 unit – 2 pieces)	1
18		1/4"-20 x 1 1/2" HH Bolt	4
19		1/4" Flat Washer	8
20	0150218	1/4"-20 Lock Nut	4

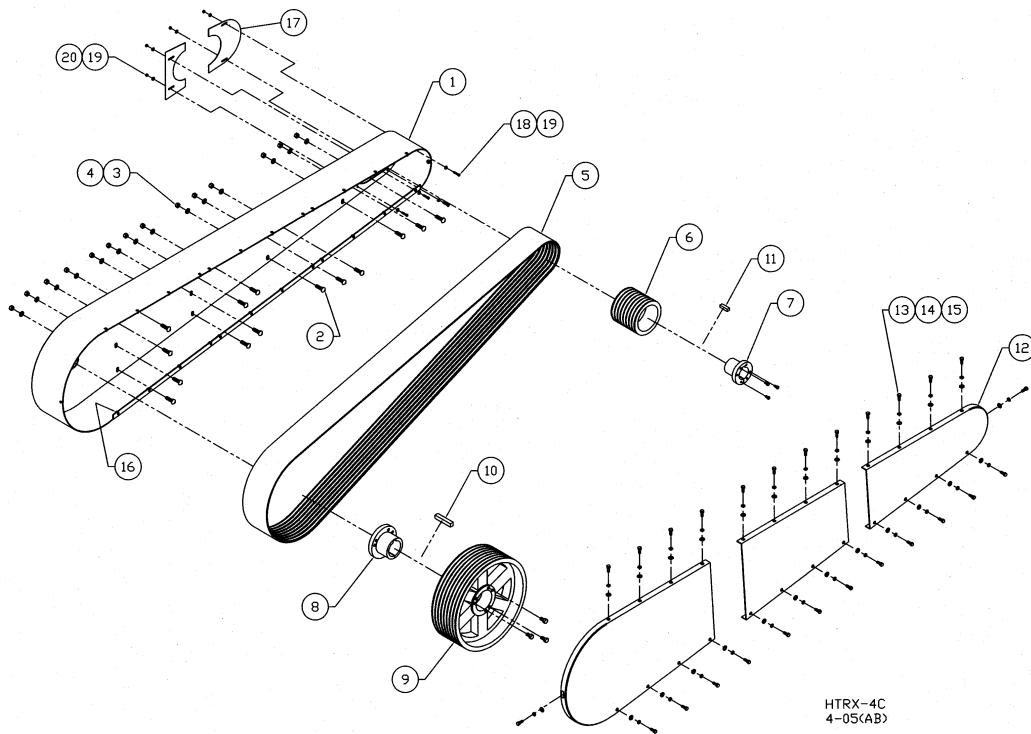

Items # 12 & # 17 are manufactured as 1 piece and sheared into sections for a tight fit. Each item is sold as a single unit, not individual pieces.

Hurricane RS

ITEM NO	PART NO	DESCRIPTION	QTY
1	19040078	Weldment, Poly Chain® Base	1
2		1/2"-13 x 1 1/2" Carriage Bolt	10
3	0150304	1/2" Flat Washer	10
4	0150206	1/2"-13 Lock Nut	10
5	0250151	Cutter Wheel Sprocket – 14M-56S-125	1
6	0250151A	Tapered Bushing – 4535 x 2 15/16	1
7	0250150	Jackshaft Sprocket – 14M-38S-125	1
8		Key – 3/4" Square x 3 1/2"	1
9		Key – 3/4" Square x 4 1/4"	1
10	0400124B	Poly Chain® Belt – 14MGT-3136-125	1
11	19040077	Weldment, Poly Chain® Guard	1
12		3/8"-16 x 1" HH Bolt	12
13	0150404	3/8" Lock Washer	12
14	0150303	3/8" Flat Washer	12
15	0150119B	3/8"-16 Hex Nut (welded inside #19040034)	12
16	19040081	Plate, Dust, Poly Chain® Guard (1 unit – 2 pieces)	1
17		1/4"-20 x 1 1/4" HH Bolt	3
18		1/4" Flat Washer	6
19	0150218	1/4"-20 Lock Nut	3

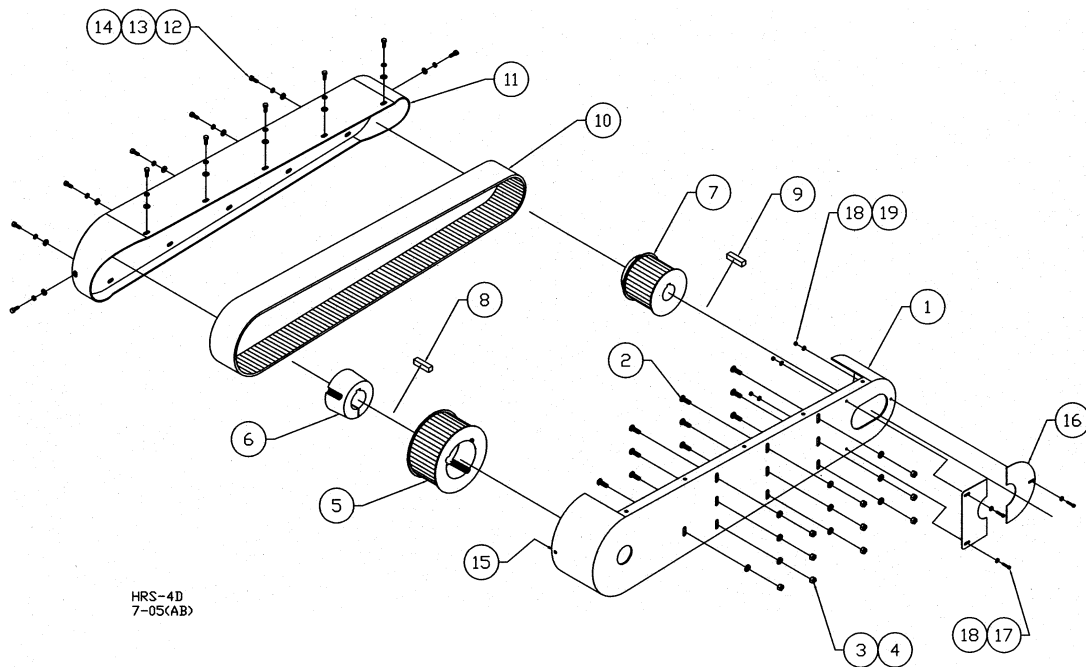

Item # 15 is manufactured as 1 piece and sheared into sections for a tight fit and is sold as a single unit, not individual pieces.

Hurricane TRX

ITEM NO	PART NO	DESCRIPTION	QTY
1	19040034	Weldment, Poly Chain® Base	1
2		1/2"-13 x 1 1/2" Carriage Bolt	10
3	0150304	1/2" Flat Washer	10
4	0150206	1/2"-13 Lock Nut	10
5	0250151	Cutter Wheel Sprocket – 14M-56S-125	1
6	0250151A	Tapered Bushing – 4535 x 2 15/16	1
7	0250150	Jackshaft Sprocket – 14M-38S-125	1
8		Key – 3/4" Square x 3 1/2"	1
9		Key – 3/4" Square x 4 1/4"	1
10	0400124A	Poly Chain® Belt – 14M-3500-125	1
11	19040024	Weldment, Poly Chain® Guard (1 unit – 2 pieces)	1
12		3/8"-16 x 1" HH Bolt	14
13	0150404	3/8" Lock Washer	14
14	0150303	3/8" Flat Washer	14
15	0150119B	3/8"-16 Hex Nut (welded inside #19040034)	14
16	19040075	Plate, Dust, Poly Chain® Guard (1 unit – 2 pieces)	1
17		1/4"-20 x 1 1/4" HH Bolt	4
18		1/4" Flat Washer	8
19	0150218	1/4"-20 Lock Nut	4

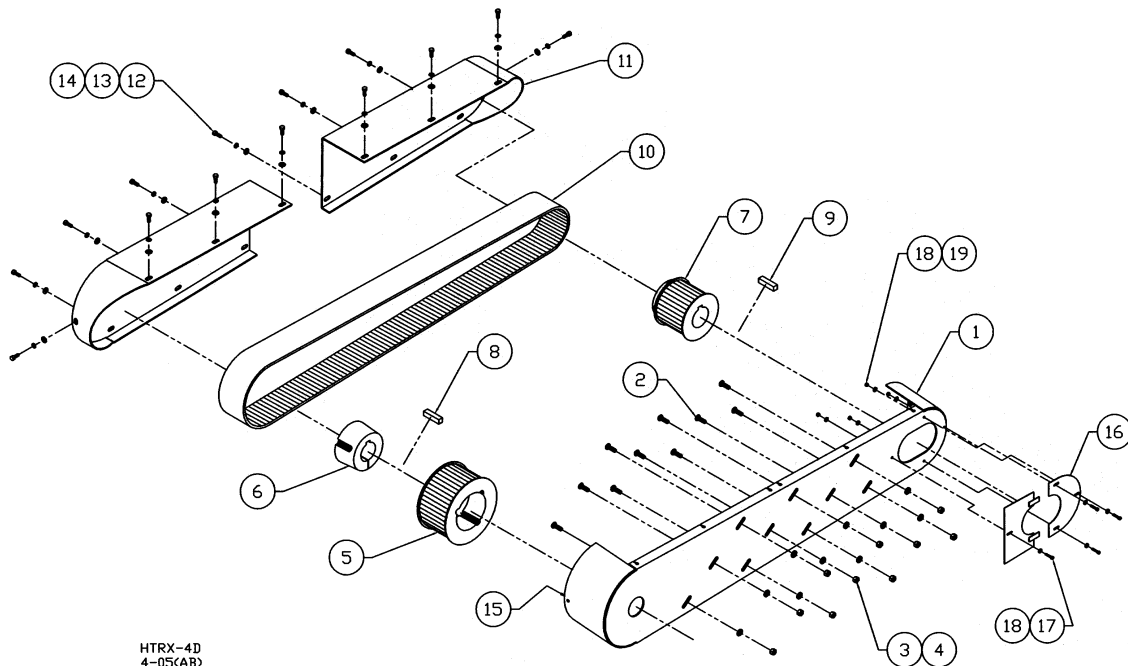

HTRX-4D
4-05(AB)

Items # 10 & # 15 are manufactured as 1 piece and sheared into sections for a tight fit. Each item is sold as a single unit, not individual pieces.

i01329108

Track Information

SMCS Code: 4170; 7000

Track adjusting systems use either grease or oil under high pressure to keep the track under tension.

Grease or oil under high pressure coming out of the relief valve can penetrate the body causing injury or death. Do not watch the relief valve to see if grease or oil is escaping. Watch the track or track adjustment cylinder to see if the track is being loosened.

The pins and bushings in a dry track pin joint can become very hot. It is possible to burn the fingers if there is more than brief contact with these components.



RUBBER TRACK ON HURRICANE TRX

i01278048

Rubber Belt Track Operation (If Equipped)

SMCS Code: 4198

The rubber part of the track assembly can easily be damaged during operation. Operate the machine with the rubber belt only if damage to the rubber belt is shallow and the damage is not harmful. However, any harmful damage to the rubber can cause the following serious problems to the entire track assembly:

- Early wear of iron core.
- Early wear of track grousers.
- Fracture of iron core.
- Fracture of track grousers.
- Cuts of steel cords
- Rubber flaking off
- Disengagement of sprocket

Such a failed track assembly needs to be replaced as a unit. In order to minimize the replacement of the track, observe the following items. In order to maximize the performance of the track, observe the following items:

- Avoid travelling at sites for demolition.
- Travelling at these sites should be avoided particularly when the machine is being swung at the same time.
- Avoid operation under salty conditions.
- Avoid combined operation of travel and swing with excessive load at rough terrain.
- Avoid operation at rocky sites.

- Avoid suddenly swinging the machine when the machine is travelling on pavement.
- Use the rubber belt tracks at temperatures within -25°C (-13°F) to 55°C (131°F). Avoid operation on hot surfaces.
- Rubber belt tracks are less stable than steel tracks. Side-to-side movement of the machine should be done very carefully.
- If the sprockets are badly worn, use a new sprocket for replacement.
- Be sure that the tracks are free of oily materials such as fuel, hydraulic oil, grease, etc.
- Avoid going over sharp obstacles at sites for demolition. Decreased life of the track, fracture of the track grousers and cut steel cords can occur.
- Disengagement of the track could occur if the track gets clear of the track roller. This could happen while the machine travels over an obstacle.

Scheduled Oil Sampling (S-O-S)

i01748356

Sampling Interval and Location of Sampling Valve

SMCS Code: 1348; 5050; 7542-008

Take the oil samples as close as possible to the standard intervals. In order to receive the full value from S-O-S oil analysis, you must establish a consistent trend of data. In order to establish a pertinent history of data, perform consistent oil samplings.

Refer to Special Publication, SEBU6250, "Caterpillar Machine Fluid Recommendations" for detailed information concerning S-O-S oil analysis and for the sampling interval for each compartment.

Consult your Caterpillar dealer for complete information and assistance in establishing an S-O-S program for your equipment.

Final Drive Oil

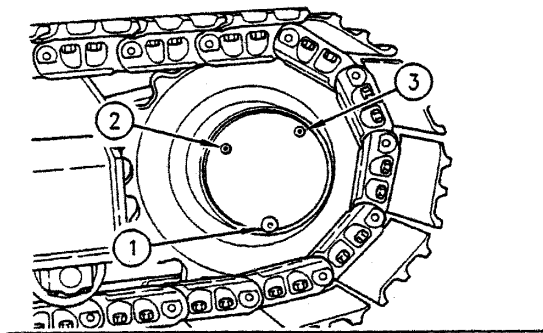
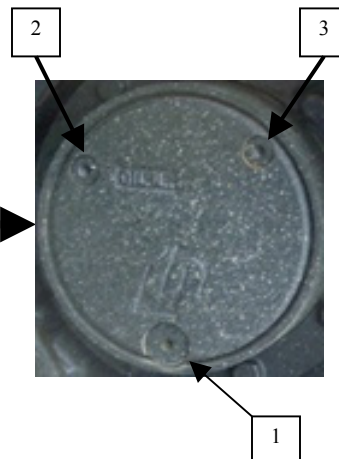

Illustration 153
 (1) Oil drain plug
 (2) Oil level plug
 (3) Oil filler plug

g00740859

Obtain an oil sample of the final drive oil through oil level plug (2).



Maintenance Interval Schedule

SMCS Code: 7000

All safety information, warnings, and instructions must be read and understood before you perform any operation or any maintenance procedure.

Before each consecutive interval is performed, all of the maintenance requirements from the previous interval must also be performed.

When Required

Track Adjustment - Inspect
 Track Adjustment - Adjust

Every 10 Service Hours or Daily

Undercarriage - Check
 Undercarriage - Check

Every 100 Service Hours

Swing Bearing - Lubricate
 Swing Gear - Lubricate

Initial 250 Service Hours

Final Drive Oil - Change

Every 250 Service Hours

Final Drive Oil Level - Check

Every 1000 Service Hours

Final Drive Oil - Change

Lubricant Viscosities and Refill Capacities

i01726403

Lubricant Viscosities

SMCS Code: 7581

Table 23

Lubricant Viscosities for Ambient Temperatures					
Compartment or System	Oil Viscosities	°C		°F	
		Min	Max	Min	Max
Swing Drive	Caterpillar HYDO	-30	+40	-22	+104
Final Drive	SAE 10W30	-30	+40	-40	+104

i01748378

Capacities (Refill)

SMCS Code: 1000; 7000

Table 24

Approximate Capacities (Refill)				
Component or System	Liters	US gal	Imp gal	Recommended Type
Each Final Drive	1.0	0.26	0.22	Caterpillar Transmission/Drive Train Oil (TDTO)

(1) Consult your Caterpillar dealer before you use biodegradable hydraulic oil. Your machine may not be compatible with biodegradable hydraulic oil.

Final Drive Oil - Change

SMCS Code: 4050-044-FLV

i01407623

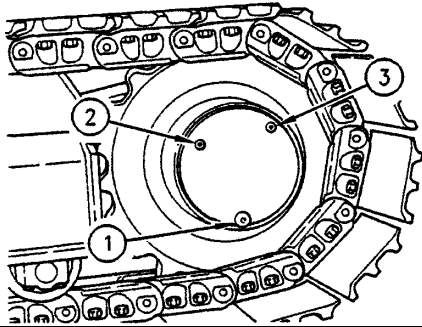

Illustration 205

g00740859

- (1) Oil drain plug
- (2) Oil level plug
- (3) Oil filler plug

1. Position one final drive so that oil drain plug (1) is at the bottom.

Note: Refer to Operation and Maintenance Manual, "General Hazard Information" for information on Containing Fluid Spillage.

2. Remove oil drain plug (1), level plug (2) and filler plug (3). Allow the oil to drain into a suitable container.
3. Clean the plugs and inspect the plugs. Replace a worn plug or a damaged plug.
4. Apply pipe sealant to oil drain plug (1), level plug (2) and filler plug (3).
5. Install drain plug (1).
6. Add oil through the opening of filler plug (3).
7. Fill the final drive to the bottom of the opening for level plug (2). Refer to Operation and Maintenance Manual, "Lubricant Viscosities" and Operation and Maintenance Manual, "Refill Capacities".
8. Install level plug (2) and filler plug (3).
9. Perform Step 1 to Step 8 on the other final drive. Do not use the same container for the oil from the final drives. The oil samples from the final drives must be separate.
10. Completely remove any oil that has spilled.
11. Start the engine and allow the final drives to operate through several cycles.
12. Stop the engine.
13. Check the oil level.
14. Maintain the oil level to the bottom of the opening for level plug (2).
15. Check the drained oil for metal chips or for particles. If there are any chips or particles, consult your Caterpillar dealer.

Note: Dispose of drained fluids according to local regulations.

Final Drive Oil Level - Check

SMCS Code: 4050-535-FLV

i01407687

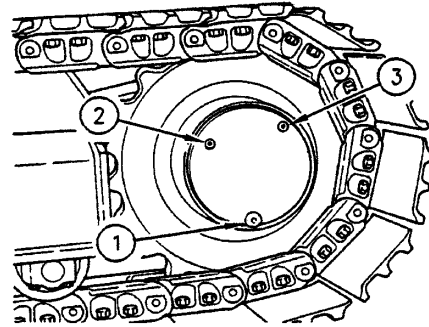

Illustration 206

g00740859

- (1) Oil drain plug
- (2) Oil level plug
- (3) Oil filler plug

1. Position one final drive so that oil drain plug (1) is at the bottom.

Note: Refer to Operation and Maintenance Manual, "General Hazard Information" for information on Containing Fluid Spillage.

2. Remove oil level plug (2).
 3. Check the oil level. The oil should be near the bottom of the opening of level plug (2).
 4. Add oil through the opening of filler plug (3), if necessary.
- Note:** Overfilling the final drive will cause the seals on the travel motor to allow hydraulic oil or water to enter the final drive. This may contaminate the final drive.
5. Clean oil level plug (2) and filler plug (3).
 6. Apply pipe sealant to oil level plug (2) and filler plug (3).
 7. Install oil level plug (2).
 8. Install oil filler plug (3).
 9. Repeat the procedure for the other final drive.

High Pressure Cylinder

This warning message is located on the inside surface of the access plate for the track adjuster.

WARNING

High Pressure Cylinder. Do not remove any parts from the cylinder until all of the pressure has been relieved. This will prevent possible personal injury or death.

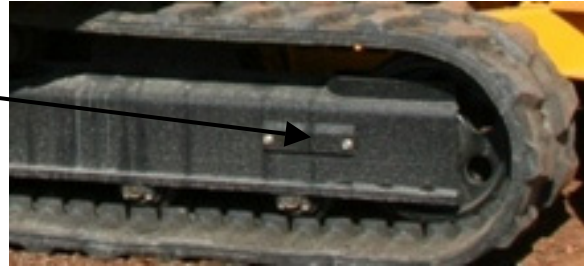

Track Adjustment - Inspect

Measuring Rubber Track Tension

1. Park the machine on a level surface.
2. Position the upper frame over the tracks at a 90° angle.
3. Lower the cutter wheel to rest on the ground, do not apply pressure.
4. Chock the track that is not being lifted off the ground. This will be the track on the same side of the machine as the cutter wheel.
5. Position a hydraulic jack under the machine next to the track to be lifted. Raise the track just enough to clear the ground.
6. Chock the lower frame in the raised position.
7. Clean the track rollers and the area around the skid plate.

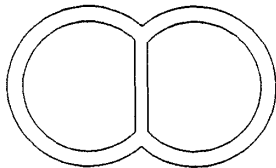

Illustration 239

8. For a machine that is equipped with the rubber tracks, locate the "omega" mark on the inside flat of the track.
9. Position the "omega" mark under the center track roller.

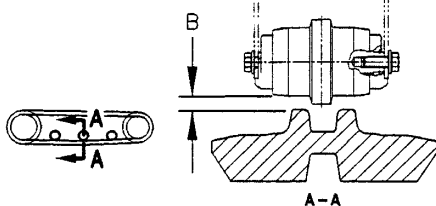

Illustration 240

The distance (B) should be 10 to 15 mm (0.4 to 0.6 inch).

10. Measure the sag in the track. The sag is measured from the bottom of the roller to the surface on the top of the track. A properly adjusted track will have 10 to 15 mm (0.4 to 0.6 inch) sag.

Track Adjustment - Adjust

SMCS Code: 4170-025

i01592596

WARNING

Personal injury or death can result from grease under pressure.

Grease coming out of the relief valve under pressure can penetrate the body causing injury or death.

Do not watch the relief valve to see if grease is escaping. Watch the track or track adjustment cylinder to see if the track is being loosened.

Loosen the relief valve one turn only.

If track does not loosen, close the relief valve and contact your Caterpillar dealer.

Tightening the Tracks

1. Remove the cover plate for the track adjustment valve.

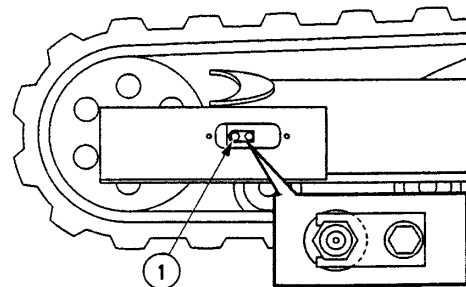

Illustration 242

g00825994

2. Wipe fitting (1) before you add grease.
3. Add grease through fitting (1) until the correct tension is reached.
4. Operate the track back and forth in order to equalize the pressure.
5. Check the amount of sag. Adjust the track, as needed.
6. Replace the cover plate for the track adjustment valve.
7. Repeat the same procedure for the other track.

TRACK MAINTENANCE

Loosening the Track

1. Remove the cover plate for the track adjustment valve.

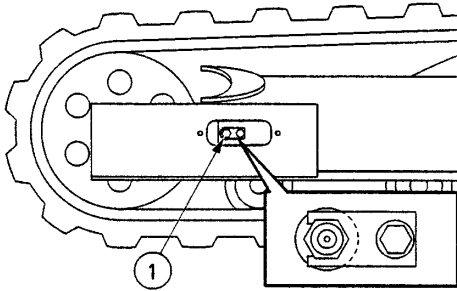

Illustration 244

g00825994

2. Loosen fitting (1) carefully until the track begins to loosen. One turn should be the maximum.
3. Tighten fitting (1) to 34 N·m (25 lb ft) when the desired track tension is reached.
4. Operate the track back and forth in order to equalize pressure.
5. Check the amount of sag in the track. Adjust the track, as needed.
6. Replace the cover plate for the track adjustment valve.
7. Repeat the same procedure for the other track.

Undercarriage - Check

SMCS Code: 4150-535

i01722112

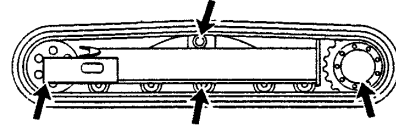

Illustration 246

g00885424

1. Check the carrier rollers, the track rollers, and the idler wheels for possible leakage.
2. Check the surface of the track, the carrier rollers, the track rollers, the idler wheels, the track shoes, and the drive sprockets. Look for signs of wear and loose mounting bolts.
3. Listen for any abnormal noises while you are moving slowly in an open area.
4. If abnormal wear exists or abnormal noises or leaks are found, consult your Caterpillar dealer.

TRACK PARTS LIST

UNDERCARRIAGE

208-0637 FRAME GP-UNDERCARRIAGE

PART OF 208-0636 UNDERCARRIAGE AR

SMCS-7050

i01730773

NOTE	REF NO	GRAPHIC REF	PART NUMBER	QTY	PART NAME						SEE PAGE
					1	2	3	4	5	6 (PRODUCT LEVEL)	
	1	1	172-1956	2	COVER						
	2	1	209-7394	1	FRAME AS-UNDERCARRIAGE						
	3	1	218-3043	2	COVER						
	4	1	218-4276	1	COVER						
	5	1	8T-4121	10	WASHER-HARD (11X21X2.5MM THK)						
M	6	1	8T-4179	4	BOLT (M12X1.75X20MM)						
M	7	1	8T-4191	10	BOLT (M10X1.5X16MM)						
	8	1	8T-4223	4	WASHER-HARD (13.5X25.5X3MM THK)						

M-METRIC PART

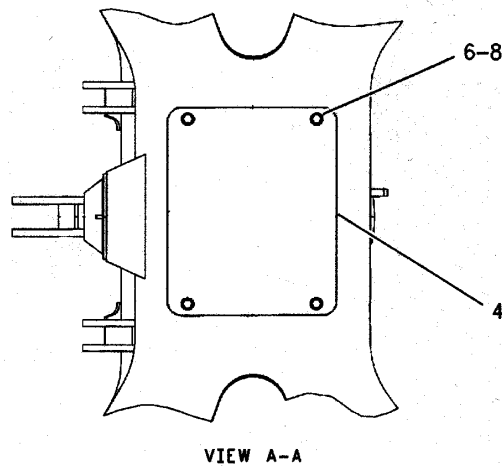
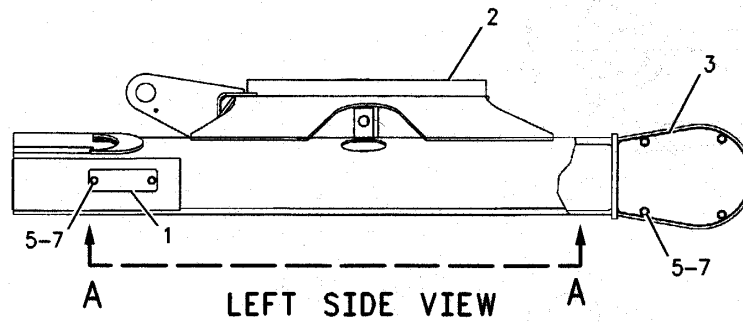

GRAPHIC #1

g00891716

TRACK PARTS LIST

UNDERCARRIAGE

191-3833 GEAR & BEARING GP-SWING

PART OF 208-0636 UNDERCARRIAGE AR

SMCS-7063

101752518

NOTE	REF NO	GRAPHIC REF	PART NUMBER	QTY	PART NAME						SEE PAGE
					1	2	3	4	5	6 (PRODUCT LEVEL)	
	1	1	140-4986	2	DOWEL						
	2	1	163-9969	1	PLATE AS						
	3	1	198-0856	1	BEARING AS						
	4	1	8T-4223	24	WASHER-HARD (13.5X25.5X3MM THK)						
M	5	1	8T-6868	48	BOLT (M12X1.75X80MM)						
M-METRIC PART											

TRACK PARTS LIST

UNDERCARRIAGE

191-3833 GEAR & BEARING GP-SWING (contd.)

101752518

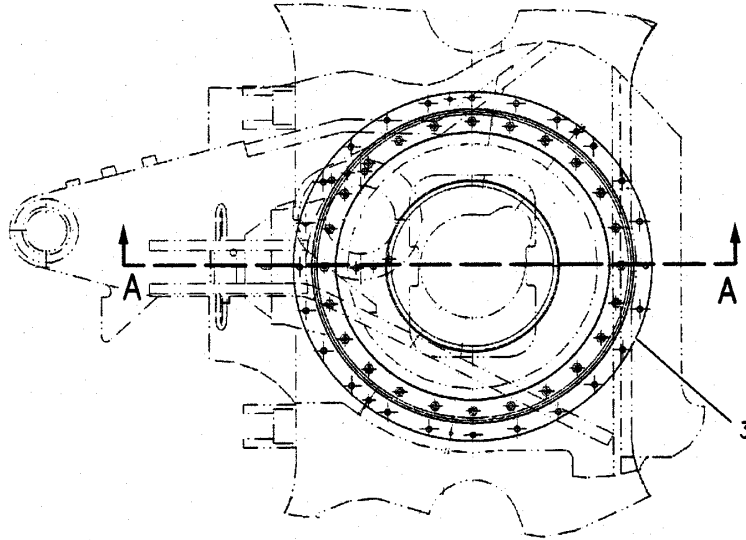

TOP VIEW

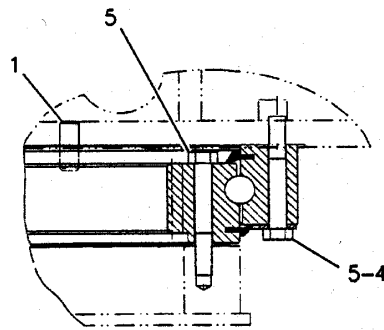

VIEW OF AREA B

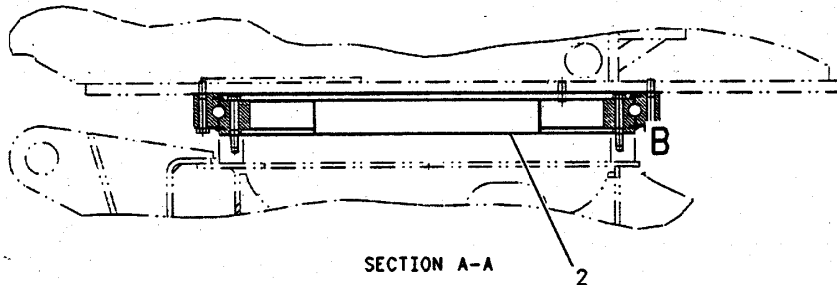

SECTION A-A

GRAPHIC #1

g00896612

TRACK PARTS LIST

UNDERCARRIAGE

155-6845 GUARD GP - TRACK GUIDE

PART OF 203-3644 TRACK GP
AN ATTACHMENT

SMCS-4177

i01732248

NOTE	REF NO	GRAPHIC REF	PART NUMBER	QTY	PART NAME						SEE PAGE
					1	2	3	4	5	6 (PRODUCT LEVEL)	
	1	1	163-7187	1	GUARD AS (RH)						
	2	1	163-7188	1	GUARD AS (LH)						
M	3	1	8T-4139	6	BOLT (M12X1.75X30MM)						
	4	1	8T-4223	6	WASHER-HARD (13.5X25.5X3MM THK)						

M-METRIC PART

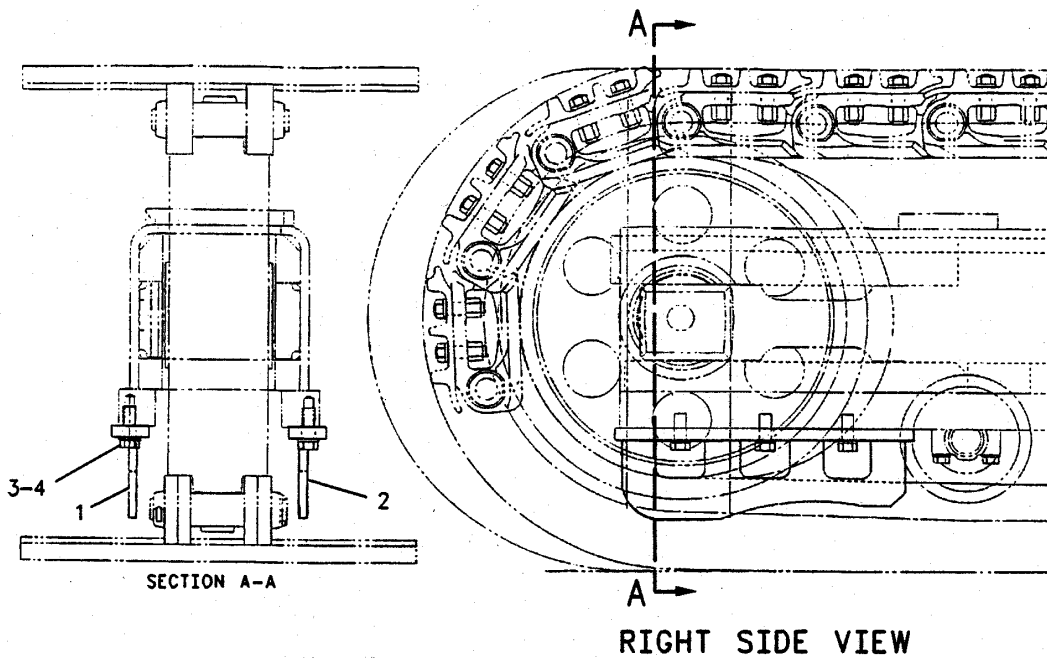

GRAPHIC #1

g00890599

TRACK PARTS LIST

UNDERCARRIAGE

217-3745 IDLER GP-FRONT

PART OF 208-0636 UNDERCARRIAGE AR

SMCS-4159

i01730779

NOTE	REF NO	GRAPHIC REF	PART NUMBER	QTY	PART NAME						SEE PAGE
					1	2	3	4	5	6 (PRODUCT LEVEL)	
	1	1	217-3746	1	IDLER AS (LH)						
	2	1	217-3747	1	IDLER AS (RH)						
	3	1	217-3761	2	SPRING AS						

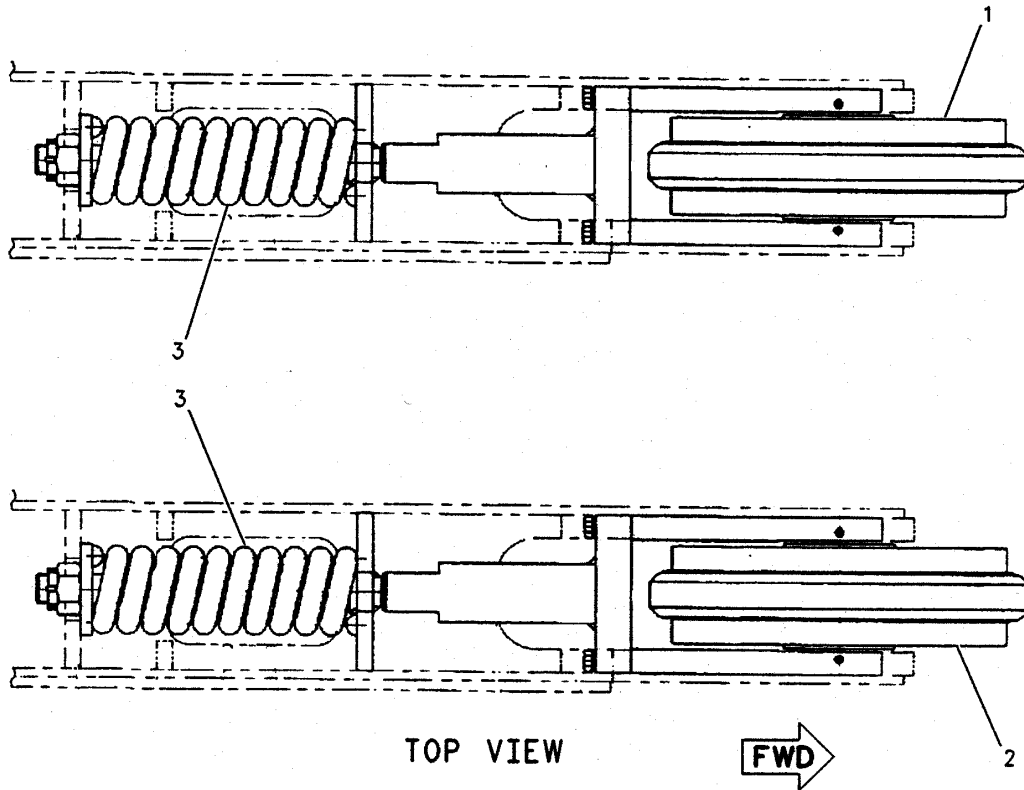

TOP VIEW



GRAPHIC #1

g00891703

TRACK PARTS LIST

UNDERCARRIAGE

158-4766 LINK GP-TRACK

PART OF 155-6844 TRACK GP
AN ATTACHMENT

SMCS-4169, 4171

i01307570

NOTE	REF NO	GRAPHIC REF	PART NUMBER	QTY	PART NAME						SEE PAGE
					1	2	3	4	5	6 (PRODUCT LEVEL)	
	1	1	158-4767	37	LINK-TRACK (RH)						
	2	1	158-4768	37	LINK-TRACK (LH)						
	3	1	158-4769	1	LINK-MASTER (RH)						
	4	1	158-4770	1	LINK-MASTER (LH)						
	5	1	158-4771	38	BUSHING						
	6	1	158-4772	37	PIN-TRACK						
	7	1	158-4773	1	PIN-MASTER						
	8	1	158-4774	1	PIN-COTTER						

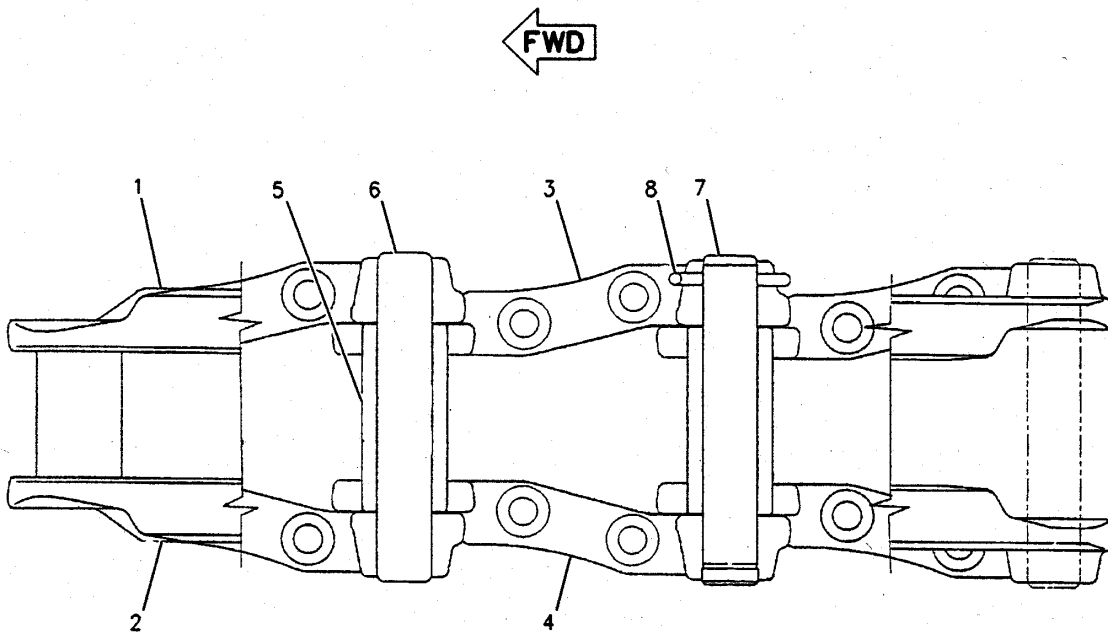

TOP VIEW

GRAPHIC #1

g00706704

TRACK PARTS LIST

UNDERCARRIAGE

158-4765 ROLLER GP-TRACK PART OF 208-0638 ROLLER GP-TRACK

SMCS-4154, 4180

i01307268

NOTE	REF NO	GRAPHIC REF	PART NUMBER	QTY	PART NAME						SEE PAGE		
					1	2	3	4	5	6 (PRODUCT LEVEL)			
	1	1	158-4710	1									
	2	1	158-4711	1									
	3	1	158-4712	2									
	4	1	158-4713	2									
	5	1	3D-4603	1									
	6	1	120-4695	2									
	7	1	158-4714	2									
	8	1	158-4715	1									
	9	1	158-4716	1									

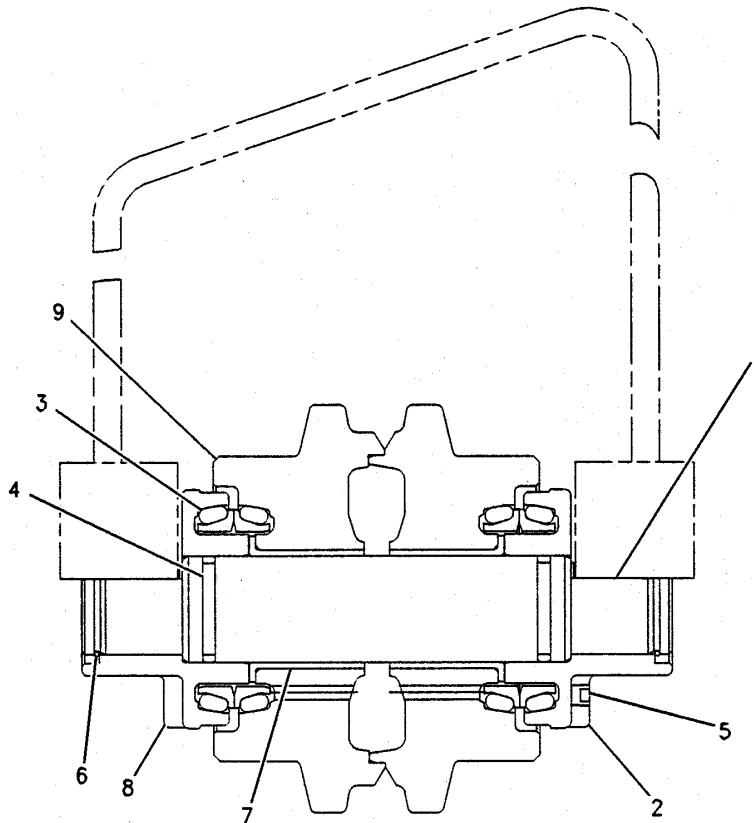

GRAPHIC #1

g00702275

TRACK PARTS LIST

UNDERCARRIAGE

208-0638 ROLLER GP-TRACK TRACK & CARRIER PART OF 208-0636 UNDERCARRIAGE AR

SMCS-4154, 4180

i01730775

NOTE	REF NO	GRAPHIC REF	PART NUMBER	QTY	PART NAME						SEE PAGE
					1	2	3	4	5	6 (PRODUCT LEVEL)	
Y	1	1	158-4765	8	ROLLER GP-TRACK						87
	2	1	172-1764	2	ROLLER AS						
M	3	1	7X-2556	2	BOLT (M16X2X100MM)						
	4	1	8T-4121	32	WASHER-HARD (11X21X2.5MM THK)						
M	5	1	8T-4132	4	NUT (M16X2 THD)						
M	6	1	8T-4182	32	BOLT (M10X1.5X45MM)						
	7	1	9X-8257	4	WASHER (17.5X30X3.5MM THK)						

QUANTITIES SHOWN ARE THOSE REQUIRED FOR BOTH LH AND RH SIDES
M-METRIC PART
Y-SEPARATE ILLUSTRATION

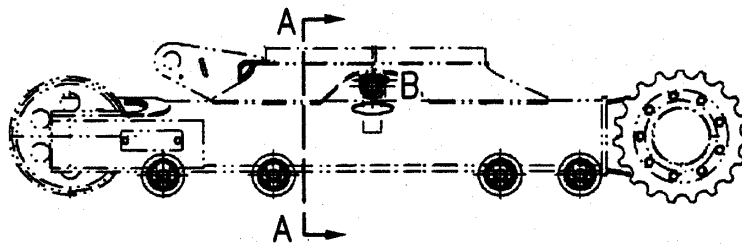

LEFT SIDE VIEW

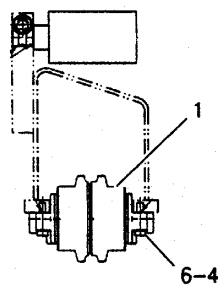

SECTION A-A

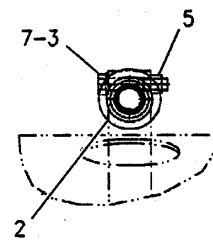

VIEW OF AREA B

GRAPHIC #1

g00891710

TRACK PARTS LIST

UNDERCARRIAGE

155-6844 TRACK GP
 400MM (15.75IN). DOUBLE GROUSER
 PART OF 203-3644 TRACK GP
 AN ATTACHMENT

SMCS-4170, 4198

01307007

NOTE	REF NO	GRAPHIC REF	PART NUMBER	QTY	PART NAME	1 2 3 4 5 6 (PRODUCT LEVEL)						SEE PAGE
Y	1	1	158-4766	1	LINK GP-TRACK							86
	2	1	158-4775	152	BOLT							
	3	1	158-4776	152	NUT							
	4	1	158-4777	38	SHOE-TRACK							

Y-SEPARATE ILLUSTRATION

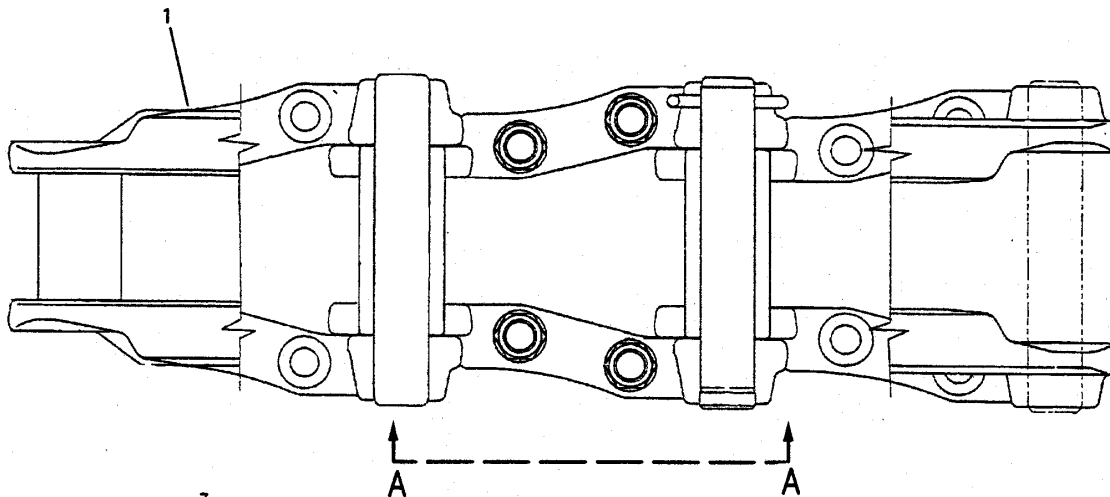

TOP VIEW

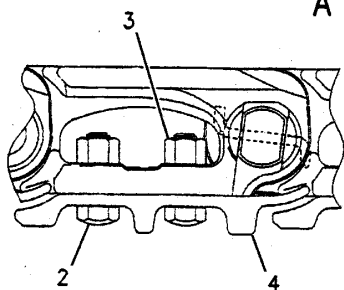

VIEW A-A

GRAPHIC #1

g00706473

TRACK PARTS LIST

UNDERCARRIAGE							
203-3644 TRACK GP							
400MM (15.75IN). TRIPLE GROUSER SHOE AN ATTACHMENT							
SMCS-4170, 4198				i01732085			
NOTE	PART NUMBER	QTY	PART NAME				SEE PAGE
			1 2 3 4 5 6 (PRODUCT LEVEL)				
Y	155-6845	1	GUARD GP-TRACK GUIDE				84
Y	155-6844	1	TRACK GP				89
Y-SEPARATE ILLUSTRATION							
<END>							
212-8975 TRACK GP							
400MM (15.75IN). RUBBER BELT AN ATTACHMENT							
SMCS-4170, 4198				i01726993			
NOTE	PART NUMBER	QTY	PART NAME				SEE PAGE
			1 2 3 4 5 6 (PRODUCT LEVEL)				
	212-8976	1	TRACK AS				
<END>							
208-0636 UNDERCARRIAGE AR							
PART OF 200-5549 COMMON AR							
SMCS-4150				i01727424			
NOTE	PART NUMBER	QTY	PART NAME				SEE PAGE
			1 2 3 4 5 6 (PRODUCT LEVEL)				
Y	208-0637	1	FRAME GP-UNDERCARRIAGE				80
Y	191-3833	1	GEAR & BEARING GP-SWING				82
Y	217-3745	1	IDLER GP-FRONT				85
Y	208-0638	1	ROLLER GP-TRACK				88
Y-SEPARATE ILLUSTRATION							
<END>							

MODEL	TYPE	ENGINE	HP	FUEL	CUTTING DEPTH	CUTTING HEIGHT	CUT SWING	NO. TEETH	WHEEL DIA.	WHEEL THICKNESS	TONGUE EXTENSION	WEIGHT (lbs.)
900H	Walk-Behind	Honda	13	Gas	9"	21"	N/A	12	12.25"	.5"	N/A	220
SP2000	Walk-Behind	Kohler	27	Gas	24"	27"	N/A	16	19"	.5"	N/A	695
SP4012	Self-Propelled	Kohler	27	Gas	13"	34"	40" arc	20	21"	1"	30"	1,550
	Self-Propelled	Briggs-Vanguard	35	Gas	13"	34"	40" arc	20	21"	1"	30"	1,650
	Self-Propelled	Lombardini	28.7	Diesel	13"	34"	40" arc	20	21"	1"	30"	1,650
SP7015	Self-Propelled	Deutz Turbo	60	Diesel	15"	43"	70" arc	32	26.5"	1"	N/A	3,500
SP7015TRX	Track-Mounted	Deutz Turbo	60	Diesel	15"	43"	70" arc	32	26.5"	1"	N/A	4,300
SP8018 TRX	Track-Mounted	Deutz Turbo	78	Diesel	18"	43"	80" arc	32	26.5"	1"	N/A	5,420
HURRICANE RS	Track-Mounted	John Deere Turbo	140	Diesel	25"	53"	360°	48	31"	1.5"	N/A	8,500
HURRICANE TRX	Track-Mounted	John Deere Turbo	140	Diesel	25"	72"	360°	64	36"	1.5"	N/A	12,000
	Track-Mounted	John Deere Turbo	175	Diesel	25"	72"	360°	64	36"	1.5"	N/A	12,000
	Track-Mounted	John Deere Turbo	250	Diesel	25"	72"	360°	64	36"	1.5"	N/A	12,000
3500D	Tow-Behind	Deutz Turbo	60	Diesel	15"	40"	80" arc	32	26.5"	1"	48"	2,900
7500	Tow-Behind	Deutz Turbo	78	Diesel	24"	46"	92" arc	48	31"	1.5"	60"	4,400

Call and ask about Carlton's line of Chippers or visit our website: www.stumpcutters.com

CARLTON—QUALITY PRODUCTS AND EXCEPTIONAL SERVICE



J.P. Carlton Company Div. DAF, Inc.
121 John Dodd Road
Spartanburg, South Carolina 29303
864-578-9335 • 800-243-9335 • FAX 864-578-0210

Carlton Owner's Manual
HURRICANE TRACK
Revised: 10/2007

Installation and Maintenance Bulletin

HPTO8TD-100

January 10, 2002

Hydraulic Power Take-off

Rotating equipment is potentially dangerous and should be properly guarded. The user should check all applicable safety codes and provide suitable guards.

The HPTO™ Hydraulic Power Take-off is a hydraulically actuated, enclosed dry clutch that requires no adjustment throughout its wear life. During a torque spike, the clutch will act as a torque limiter by slipping to absorb the shock load. The bearings in the clutch are greased for the life of the product.

A **Microprocessor Controller** provides remote push button controlled clutch engagement of the HPTO. The controller is capable of monitoring clutch pressure, engine speed, and an equipment safety switch. The controller features an ISO standard symbol display with LED's that light to indicate system conditions.

Refer to Controller I&M Bulletin for complete information regarding controller installation, operation, and troubleshooting.

A **Hydraulic Manifold Assembly** controls the pressure required for clutch engagement. Critical system components such as: a DC coil, pressure regulating cartridge, and a pressure switch are included in the manifold assembly.

TORQUE SETTING

The precise setting of the hydraulic pressure acting on the internal piston controls the torque of the HPTO clutch. Alternate torque settings are available for various engine requirements. Consult PT Tech® if a change of torque setting is necessary.

MOUNTING AND ORIENTATION

The HPTO is manufactured to mount to SAE #3 flywheel housing. It will accommodate the following flywheels.

- SAE J620d 11-1/2 Industrial engine
- SAE J618 12" Automotive style*
- SAE J618 13" Automotive style*

*NOTE: Adaptor ring is needed for automotive style flywheels. *Contact PT Tech for selection.*

PRE-INSTALLATION CHECK

Prior to installation, the following should be checked:

1. Check that the location of the sheave matches with the location of the driven equipment sheave. Consult PT Tech for belt load and centerline distances. **Note: maintaining this distance will provide for designed bearing life.**
2. Check the mounting surfaces and the bolt holes to make sure that they are clean. This is important for a proper connection.
3. Verify that the gear pump on the customer's equipment is live when the engine is idling. **ATTENTION: hydraulic system pressure must be present for the engagement of the clutch. A minimum of 400 psi is required at all times.**

4. Check that the oil return line from the clutch manifold will be isolated from any return line that is pressurized. **ATTENTION: the oil return line from the manifold must not be attached to anything that could potentially create pressure in the line. The maximum height that the tank can be mounted above the centerline of the HPTO clutch is 4 feet. If tank is too high, over pressurization of internal shaft seals may result.**
5. Verify that all hoses and fittings (customer supplied) for making the hydraulic connections to the HPTO components are properly sized and available. *See supplied drawings for fitting sizes.*

HPTO INSTALLATION INSTRUCTIONS

For long, trouble-free life, the following instructions should be adhered to:

1. Inspect and clean the mounting faces of the engine flywheel and housing. Threaded bolt holes should be clean and free of debris.

Note: For flat “automotive” style flywheels follow step 2; otherwise proceed to step 3.

2. For automotive (flat) type flywheel size 12” or 13”, mount adaptor plate to flywheel. Torque bolts to 44 lb-ft. *Consult PT Tech for adapter plate if required.*
3. Locate the flywheel mounting bolts found in the plastic bag labeled, “Flywheel Mounting Bolt”. They are 3/8-16 UNC by 1½ inch long hex head cap screws.

4. Install flywheel ring gear to engine flywheel using the “Flywheel Mounting Bolts”. Torque all FLYWHEEL BOLTS to 44 lb-ft. **ATTENTION: do not install washers under the heads of the bolts, as this may cause interference with the speed pickup that is installed later.**
5. Using the lifting plate and lifting straps (not provided), raise the HPTO and mount the housing of the HPTO to the engine housing.

ATTENTION: the HPTO has one friction plate. The gear teeth of the plate must be aligned with the flywheel ring gear while mounting the clutch to the engine housing.

Note: Tilt shaft of HPTO up so friction plate teeth engage drive ring. Rotate HPTO down so friction plate teeth are fully engaged.



WARNING: do not follow standard Twin Disc practice by locking the disc pack together. DO NOT plug manifold drain port and pressurize or internal damage WILL occur.

6. Locate the housing mounting bolts found in the plastic bag labeled, “Housing Mounting Bolts”. They are 3/8 – 16 UNC by 1 1/4 inch long hexhead capscrews.

Note: 10 mm diameter mounting bolt size may be required by some engine manufacturers.

7. Install all housing bolts and torque all HPTO HOUSING mounting bolts to 44 lb-ft.

8. Once the HPTO housing is piloted and flush with the engine housing, you can remove the crane support.
 9. Install customer supplied sheave and QD bushing to the output shaft of the HPTO. Insure that belts (once installed) will be aligned and track straight.
 10. Tension Belts according to Equipment Manufactures specifications.
 11. Install proper safety guards (not supplied by PT Tech®).
 12. The **Manifold Assembly** has been preinstalled on the HPTO Clutch at the factory. Do not remove the manifold unless rebuilding the HPTO unit. See *manifold drawing provided for hose fitting sizes and connection locations*.
 13. Install the **Microprocessor Controller** and all electrical wiring per the Controller I&M Bulletin.
- Hydraulic Instructions**
Refer to the manifold and hydraulic schematic provided for all hydraulic connections.
14. All hoses must be thoroughly flushed. All hoses should be ½" diameter minimum that are connected to the "inlet" and "tank" ports on the manifold. (All hose is customer supplied.)
 15. Connect all hoses per the hydraulic schematic provided.
 16. Insure that the hydraulic fluid reservoir is filled to the proper fluid level.
 17. Insure that there is a clean 15-micron minimum oil filter in the hydraulic system.

MAINTENANCE INSTRUCTIONS

The HPTO requires simple routine maintenance by maintaining the proper oil level in the hydraulic reservoir and replacing the oil filter when required by the equipment manufacturer. Maintenance and inspections should be performed as follows.

Daily Inspection:

The following items should be checked daily.

1. With the clutch disengaged and the **ENGINE OFF** in a cooled condition, the oil level indicator on the oil reservoir should be visually checked to insure that the oil level is at the proper level. If needed, add additional oil to the reservoir.

500 hours of operation:

The following items should be checked after the **first 500 hours** of operation and **every 500 hours** after that:

1. Check all HPTO bolted connections and hydraulic connections.
2. Change the equipment system oil and filter per equipment manufacturer's recommendations.

5000 hours of operation:

The HPTO unit must be serviced and inspected after 5000 hours of operation. If the HPTO unit is allowed to operate beyond this point, the torque may drop rapidly and possible damage to the unit could occur.

SERVICE INSTRUCTIONS

The HPTO can be reconditioned in the field or sent back to PT Tech. Contact PT Tech if any portions of these service instructions are unclear.

DISASSEMBLY INSTRUCTIONS

Refer to exploded view drawing HPTO8TD-100 sheet 2 of 2.

1. Carefully remove all wiring and hydraulic hose connections to the manifold. **ATTENTION: Leave manifold mounted to the HPTO at this time.**
2. Remove speed pickup sensor (Item 27).
3. Remove sheave and QD bushing from the shaft.
4. Use lifting device to support HPTO then remove all housing bolts (Item 22).
5. The HPTO can now be removed from the engine and placed on a suitable working surface.
6. Remove o-ring plug (Item 28) from shaft end. **Important: keep area around the o-ring plug clean and free from debris.**
7. Loosen bolt on clamp nut (Item 16) and remove clamp nut off of shaft.
8. Remove piston (Item 9) from shaft. *Note: Install qty. of 3, 3/8-16 threaded bolts into holes in piston to assist in piston removal.*

Note: backplate (Item 10) will come off with the piston.

9. Remove all seals from piston, shaft and backplate (Items 25,17 & 18).
10. Remove quantity of three springs (Item 21).
11. Remove endplate (Item 8) by utilizing the 3/8-16 threaded holes in the endplate and 1/2-13 threaded hole in the end of the shaft.

ATTENTION: The endplate is a press fit and will require a fixture to remove the endplate from the shaft.

12. Remove key (Item 14).
13. Remove retaining ring (Item 26).
14. Push shaft 1" axially toward the endcover (Item 6). The I.D. of bearing (Item 2) will then be loose. Remove Ball bearing.
15. Move shaft axially 1" back into position so the retaining ring (Item 19) can be removed.

Important: retaining ring must be removed from shaft or damage will occur when removing the shaft.

16. Remove seal (Item 15).
17. Press shaft (Item 7) out of endcover (Item 6) by pushing the shaft axially towards the endcover.
18. Remove qty. of 2, hook ring piston seals (Item 20) from shaft.
19. Remove spherical roller bearing (Item 11).
20. Remove two retaining rings (Item 33).

21. Remove two seals from endcover (Items 12 & 13).

22. Clean area around manifold and endcover.

Important: Keep endcover and manifold ports clean and free from debris.

23. Remove four bolts (Item 38) from manifold and remove manifold (Item 37).

REBUILD INSTRUCTIONS

Refer to exploded view drawing
HPTO8TD-100 sheet 2 of 2.

Endcover Assembly

1. Apply Loctite 620 to steel cage of seals (Items 12 & 13).
2. Install qty of 2, seals (Items 12 & 13) into bore in endcover (Item 6). Press seals lightly. *Note the direction of seal lip on drawing per Figure 1.*

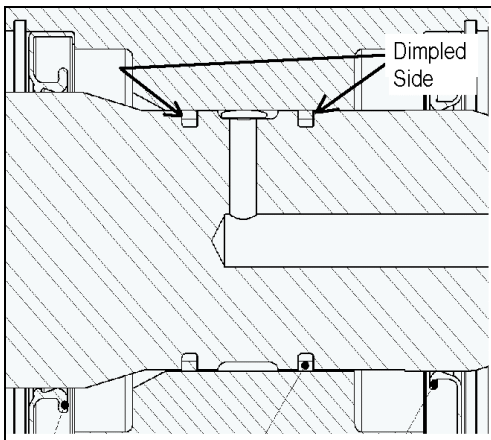

Figure 1

3. Apply Mobilfluid 424 oil or similar to seal lip (Items 12 & 13).
4. Install qty. of 2, retaining rings (Items 33) and verify retaining rings are seated in grooves.

Shaft Assembly

1. Using bearing heater, heat I.D. of bearing (Item 11) to 250 °F. Using protective gloves, slide bearing onto shaft (Item 7) until bearing contacts the shoulder on the shaft. *See Figure 2.*

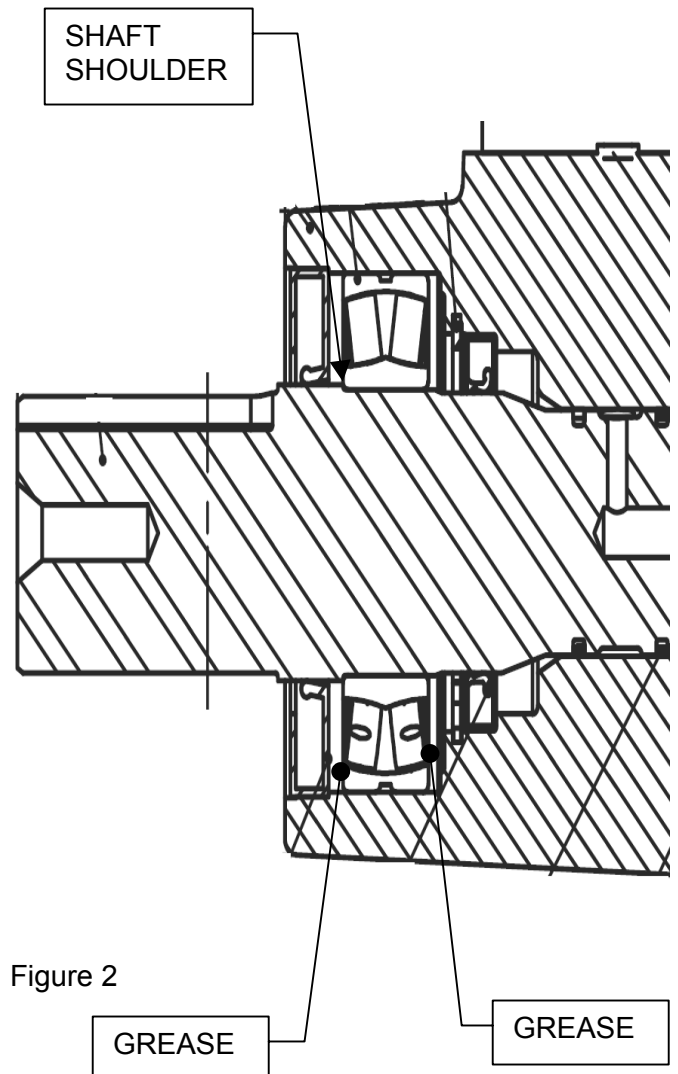

Figure 2

2. Allow shaft to cool completely.
3. Clean qty. of 2, hook piston rings (Item 20) prior to installation.
4. Lube shaft diameter and hook piston rings with Mobilfluid 424 or similar oil.
5. Using piston ring pliers, install hook piston rings onto shaft in the configuration shown in Figure 1 and close hooks once the rings are installed on the shaft. **ATTENTION: the**

orientation of the dimpled side of the rings are extremely important.

Endcover Sub-assembly

ATTENTION: Check for burrs or debris in bore of endcover at oil inlet and outlet holes.

1. Pack bearing (Item 11) on shaft with **Pennzlobe EM grease only** to 20% capacity on outer bearing race.
2. Pack end of endcover with the retaining ring with **Pennzlobe EM grease only** to 20% capacity on outer diameter. See figure 2 for location where grease should be packed during this step.
3. Lower end cover down over the shaft and hook piston rings. **ATTENTION: insure that hooked piston rings lead into the end cover with out binding. Insure that seal lip does not roll back during shaft installation.**
4. Pack endcover (Item 6) with **Pennzlobe EM grease only** to 20% capacity on the outer diameter.
5. Using retaining ring pliers, install retaining ring (Item 19) onto shaft. **Attention: insure that the retaining ring is completely seated in groove in shaft.**
6. Pack ball bearing (Item 2) **Pennzlobe EM grease only** to 20% capacity on the outer bearing race.

Note: Bearing (Item 2) should have 1 seal and no grease when

removed from the manufacturers package.

7. Lightly lube ID and OD of bearing with Mobilifluid 424 or similar oil. Thread ½-13 rod into shaft. Use a bearing press fixture that contacts the inner bearing race. Install bearing and fixture over threaded rod. Refer to Figure 3 for orientation.

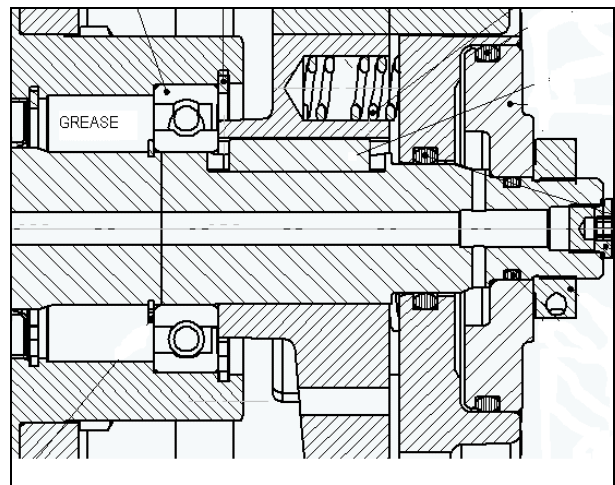

Figure 3

8. Draw bearing onto shaft using a hex nut on the threaded rod. Bearing will stop against retaining ring.
9. Install retaining ring (Item 26) and verify retaining ring is seated in groove.
10. Insert key (Item 14) into keyway of shaft end.
11. Install housing (Item 5) into endcover (Item 6).
12. Install qty. of 6, hexhead bolts (Item 23) and torque to 150 lb-ft. Apply Loctite 262 to threads of bolt.

**I & M BULLETIN
HPTO8TD-100
HYDRAULIC POWER TAKE-OFF**

Note: do not use any washers. Note:
orientation of housing to endcover as
shown on assembly drawing.

Clutch Sub-assembly

1. Press qty. of 3, dowel pins (Item 3) into endplate (Item 8). Apply Loctite 609 to dowel pins before installing. Dowel pins should be 1-1/4" above surface.
2. Align endplate (Item 8) with shaft and key. Apply Loctite 609 to shaft. Use a fixture and 1/2-13 threaded rod (threaded in shaft) to draw endplate onto shaft. Note: end plate will stop against bearing (Item 2).
3. Remove the threaded rod from shaft end. **ATTENTION: Using flashlight insure that there are no metal burrs or chips inside threaded center hole of shaft after removing threaded rod.**
4. Install hex o-ring plug (Item 28) into shaft end and tighten until snug.
5. Install qty. of 3, die springs (Item 21) into endplate (Item 8).
6. Install friction plate (Item 1) into end plate. Note: friction plate will loosely pilot onto endplate step. Note: friction surfaces must be free of oil and contamination.
7. Lightly coat o-ring (Item 17) with Mobilfluid 424 or similar oil and install into I.D. of groove piston (Item 9).
8. Lightly coat o-ring (Item 25) with Mobilfluid 424 or similar oil and install into O.D. groove in shaft (Item 1).
9. Lightly coat o-ring (Item 18) with Mobilfluid 424 or similar oil and install into O.D. groove in backplate (Item 10).
10. Install backplate (Item 10) over shaft end and into piston cavity. **ATTENTION: do not pinch o-ring in O.D. groove of fixed end plate and o-ring on shaft while installing.**
11. Install piston (Item 9) into dowel pins of endplate (Item 8). ***ATTENTION: do not pinch o-ring in I.D. groove of piston while installing over shaft.***
12. Using spanner wrench install clamp nut (Item 16) onto end of shaft. Tighten locknut until backplate (Item 10) stops moving.
13. Torque lockscrew on clamp nut (Item 16) to 70 lb-in.
14. Pack other end of endcover with **Pennzube EM grease only** to 20% capacity.
15. Install seal (Item 15) into endcover (Item 6). *NOTE: orientations of seal lip per Figure 2.*
16. Install o-ring (Item 31) into piston (Item 32) and insert into endcover.
17. Insert die spring (Item 30) into piston (Item 32) and endcover.
18. Install qty. of 4, hexhead capscrews (Item 37) p/n HHD08-06C36-XX and Manifold Assembly (Item 38) to the top of the endcover. Torque bolts to 47 lb-ft.
19. Follow Installation Instruction (at the beginning of this manual) for mounting the HPTO8TD to the engine.

I & M BULLETIN
HPTO8TD-100
HYDRAULIC POWER TAKE-OFF

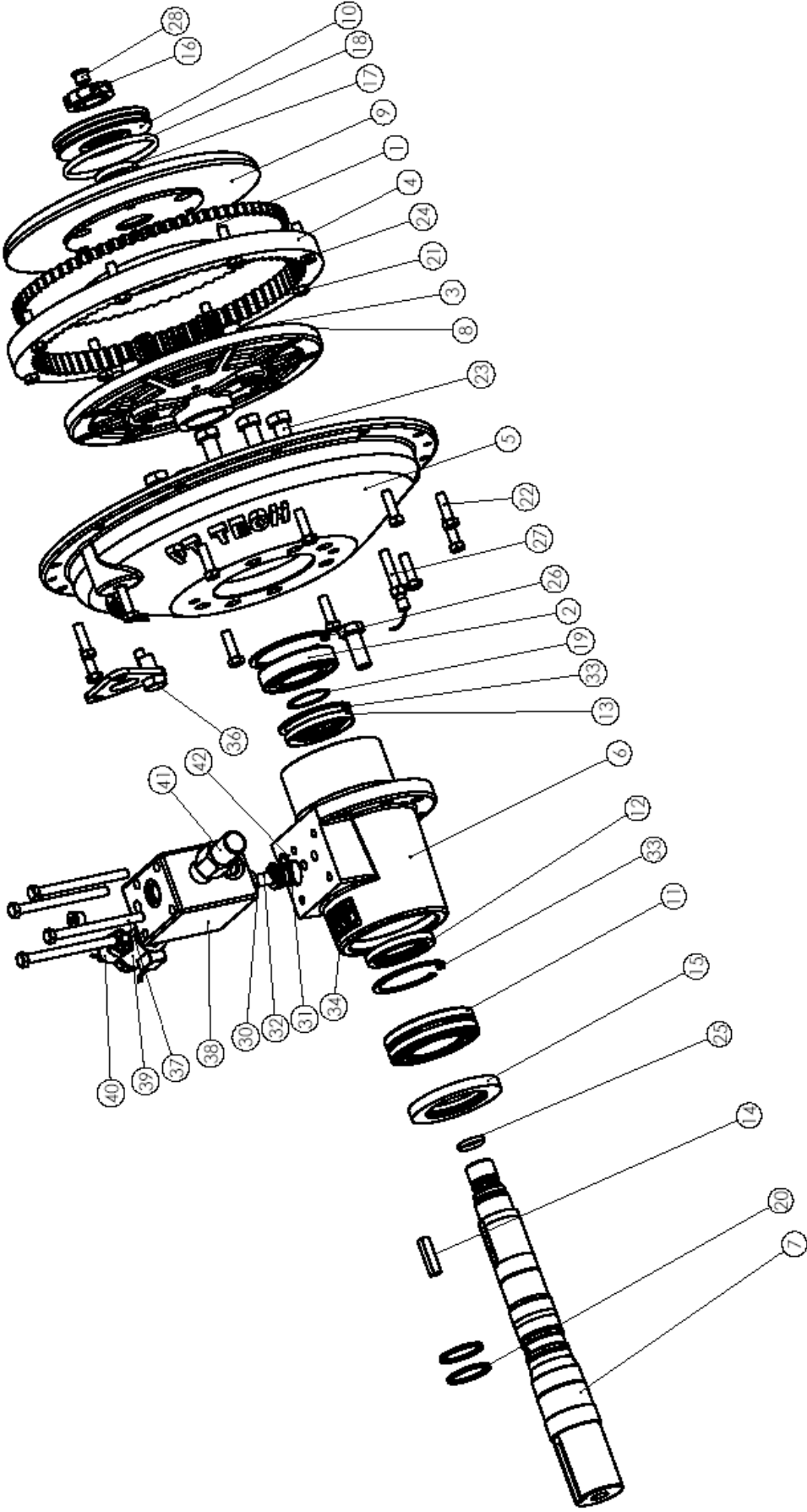

REVISION LOG SHEET

REV	DATE	INITIALS	CHANGES MADE
	1/10/02	MC/glj	Newly created in word.
A	2/26/02	BH	Added Wiring Schematic and Hydraulic Schematic to end of file.
B	4/5/02	BH	Added Controller Functions section and updated troubleshooting section.
C	4/24/02	BH	Added installation of speed pickup by customer.
D	8/26/02	BH	Speed pickup was set at 1-1/4 turns out. Shielded wire was connected to pin 12. Now spliced into pin 11.
E	11/21/02	BH	Updated CMCCU-004 drawing with simplified controller cutout.
F	1/16/03	BH	Updated controller functions per firmware B1030106A.
G	2/3/03	BH/cc	Added attention note about no washers under the heads of the flywheel bolts.
H	9/4/03	BH	Updated controller callouts to match that of controller decal.
I	11/25/03	BH	Updated hydraulic schematic to callout 3/4" hose for HPTO12 unit.
J	12/29/03	BH	Removed controller documentation and created a separate controller I&M Bulletin.
K	1/26/04	BH	Added warning against pressurizing the manifold drain port to lock disc pack during installation.
L	4/19/04	BH/rr	Updated hydraulic schematic to add 3D view.
M	8/18/04	BH/mc	Moved spherical bearing to contact shaft step.

Installation and Maintenance Bulletin

HPTO10TD-100

May 7, 2003

Hydraulic Power Take-off

Rotating equipment is potentially dangerous and should be properly guarded. The user should check all applicable safety codes and provide suitable guards.

The HPTO™ Hydraulic Power Take-off is a hydraulically actuated, enclosed dry clutch that requires no adjustment throughout its wear life. During a torque spike, the clutch will act as a torque limiter by slipping to absorb the shock load. The bearings in the clutch are greased for the life of the product.

A **Microprocessor Controller** provides remote push button controlled clutch engagement of the HPTO. The controller is capable of monitoring clutch pressure, engine speed, and an equipment safety switch. The controller features an ISO standard symbol display with LED's that light to indicate system conditions.

Refer to Controller I&M Bulletin for complete information regarding controller installation, operation, and troubleshooting.

A **Hydraulic Manifold Assembly** controls the pressure required for clutch engagement. Critical system components such as: a DC coil, pressure regulating cartridge, and a pressure switch are included in the manifold assembly.

TORQUE SETTING

The precise setting of the hydraulic pressure acting on the internal piston controls the torque of the HPTO clutch. Alternate torque settings are available for various engine requirements. Consult PT Tech® if a change of torque setting is necessary.

MOUNTING AND ORIENTATION

The HPTO is manufactured to mount to SAE #3 flywheel housing. It will accommodate the following flywheels.

- SAE J620d 11-1/2 Industrial engine
- SAE J618 12" Automotive style*
- SAE J618 13" Automotive style*

*NOTE: Adaptor ring is needed for automotive style flywheels. *Contact PT Tech for selection.*

PRE-INSTALLATION CHECK

Prior to installation, the following should be checked:

1. Check that the location of the sheave matches with the location of the driven equipment sheave. Consult PT Tech for belt load and centerline distances. **Note: maintaining this distance will provide for designed bearing life.**
2. Check the mounting surfaces and the bolt holes to make sure that they are clean. This is important for a proper connection.
3. Verify that the gear pump on the customer's equipment is live when the engine is idling. **ATTENTION: hydraulic system pressure must be present for the engagement of the clutch. A minimum of 400 psi is required at all times.**

4. Check that the oil return line from the clutch manifold will be isolated from any return line that is pressurized. **ATTENTION: the oil return line from the manifold must not be attached to anything that could potentially create pressure in the line. The maximum height that the tank can be mounted above the centerline of the HPTO clutch is 4 feet. If tank is too high, over pressurization of internal shaft seals may result.**
5. Verify that all hoses and fittings (customer supplied) for making the hydraulic connections to the HPTO components are properly sized and available. *See supplied drawings for fitting sizes.*

HPTO INSTALLATION INSTRUCTIONS

For long, trouble-free life, the following instructions should be adhered to:

1. Inspect and clean the mounting faces of the engine flywheel and housing. Threaded bolt holes should be clean and free of debris.

Note: For flat “automotive” style flywheels follow step 2; otherwise proceed to step 3.

2. For automotive (flat) type flywheel size 12” or 13”, mount adaptor plate to flywheel. Torque bolts to 44 lb-ft. *Consult PT Tech for adapter plate if required.*
3. Locate the flywheel mounting bolts found in the plastic bag labeled, “Flywheel Mounting Bolt”. They are 3/8-16 UNC by 2½ inch long hex head cap screws.

4. Install flywheel ring gear to engine flywheel using the “Flywheel Mounting Bolts”. Torque all FLYWHEEL BOLTS to 44 lb-ft. **ATTENTION: do not install washers under the heads of the bolts, as this may cause interference with the speed pickup that is installed later.**
5. Using the lifting plate and lifting straps (not provided), raise the HPTO and mount the housing of the HPTO to the engine housing.

ATTENTION: the HPTO has two friction plates. The gear teeth of the plate must be aligned with the flywheel ring gear while mounting the clutch to the engine housing.

Note: Tilt shaft of HPTO up so friction plate teeth engage drive ring. Rotate HPTO down so friction plate teeth are fully engaged.



WARNING: do not follow standard Twin Disc practice by locking the disc pack together. DO NOT plug manifold drain port and pressurize or internal damage WILL occur.

6. Locate the housing mounting bolts found in the plastic bag labeled, “Housing Mounting Bolts”. They are 3/8 – 16 UNC by 1 1/4 inch long hexhead capscrews.

Note: 10 mm diameter mounting bolt size may be required by some engine manufacturers.

7. Install all housing bolts and torque all HPTO HOUSING mounting bolts to 44 lb-ft.

8. Once the HPTO housing is piloted and flush with the engine housing, you can remove the crane support.
9. Install customer supplied sheave and QD bushing to the output shaft of the HPTO. Insure that belts (once installed) will be aligned and track straight.
10. Tension Belts according to Equipment Manufactures specifications.
11. Install proper safety guards (not supplied by PT Tech®).
12. The **Manifold Assembly** has been preinstalled on the HPTO Clutch at the factory. Do not remove the manifold unless rebuilding the HPTO unit. See *manifold drawing provided for hose fitting sizes and connection locations*.
13. Install the **Microprocessor Controller** and all electrical wiring per the Controller I&M Bulletin.

Hydraulic Instructions

Refer to the manifold and hydraulic schematic provided for all hydraulic connections.

14. All hoses must be thoroughly flushed. All hoses should be ½" diameter minimum that are connected to the "inlet" and "tank" ports on the manifold. (All hose is customer supplied.)
15. Connect all hoses per the hydraulic schematic provided at the end of this document.
16. Insure that the hydraulic fluid reservoir is filled to the proper fluid level.

17. Insure that there is a clean 15-micron minimum oil filter in the hydraulic system.

MAINTENANCE INSTRUCTIONS

The HPTO requires simple routine maintenance by maintaining the proper oil level in the hydraulic reservoir and replacing the oil filter when required by the equipment manufacturer. Maintenance and inspections should be performed as follows.

Daily Inspection:

The following items should be checked daily.

1. With the clutch disengaged and the **ENGINE OFF** in a cooled condition, the oil level indicator on the oil reservoir should be visually checked to insure that the oil level is at the proper level. If needed, add additional oil to the reservoir.

500 hours of operation:

The following items should be checked after the **first 500 hours** of operation and **every 500 hours** after that:

1. Check all HPTO bolted connections and hydraulic connections.
2. Change the equipment system oil and filter per equipment manufacturer's recommendations.

5000 hours of operation:

The HPTO unit must be serviced and inspected after 5000 hours of operation. If the HPTO unit is allowed to operate beyond this point, the torque may drop rapidly and possible damage to the unit could occur.

SERVICE INSTRUCTIONS

The HPTO can be reconditioned in the field or sent back to PT Tech. Contact PT Tech if any portions of these service instructions are unclear.

DISASSEMBLY INSTRUCTIONS

Refer to exploded view drawing HPTO10TD-100 sheet 2 of 2.

1. Carefully remove all wiring and hydraulic hose connections to the manifold. **ATTENTION: Leave manifold mounted to the HPTO at this time.**
2. Remove speed pickup sensor (Item 4).
3. Remove sheave and QD bushing from the shaft.
4. Use lifting device to support HPTO then remove all housing bolts (Item 33).
5. The HPTO can now be removed from the engine and placed on a suitable working surface.
6. Remove o-ring plug (Item 30) from shaft end. **Important: keep area around the o-ring plug clean and free from debris.**
7. Loosen bolt on clamp nut (Item 35) and remove clamp nut off of shaft.
8. Remove piston (Item 9) from shaft. *Note: Install qty. of 3, 3/8-16 threaded bolts into holes in piston to assist in piston removal.*

Note: backplate (Item 14) will come off with the piston.

9. Remove all seals from piston, shaft and backplate (Items 10, 18 & 19).
10. Remove quantity of three springs (Item 41).
11. Remove two friction plates (Item 6) and separator plate (Item 7)
12. Remove endplate (Item 3) by utilizing the 1/2-13 threaded holes in the endplate and 1/2-13 threaded hole in the end of the shaft.
ATTENTION: The endplate is a press fit and will require a fixture to remove the endplate from the shaft.
13. Remove key (Item 36).
14. Remove seal (Item 28)
15. Remove retaining ring (Item 22).
16. Remove seal cover (Item 17)
17. Push shaft (small end) 1" axially toward the endcover (Item 2). The I.D. of bearing (Item 27) will then be loose. Remove cylindrical bearing (Item 27).
18. Press shaft (Item 8) out of endcover (Item 2) by pushing the shaft (small end) axially towards the endcover.
19. Remove qty. of 2, hook ring piston seals (Item 5) from shaft.
20. Remove retaining ring (Item 26) spherical roller bearing (Item 13).
21. Remove two retaining rings (Item 24 & 25).

22. Remove two seals from endcover (Items 16 & 12).
23. Clean area around manifold and endcover.

Important: Keep endcover and manifold ports clean and free from debris.

24. Remove four bolts (Item 45) from manifold and remove manifold (Item 48).
25. Remove piston (Item 20), o-ring (Item 40) and die spring (Item 23).

REBUILD INSTRUCTIONS

Refer to exploded view drawing HPTO10TD-100 sheet 2 of 2.

Endcover Assembly

1. Apply Loctite 620 to steel cage of seals (Items 16 & 12).
2. Install qty of 2, seals (Items 16 & 12) into bore in endcover (Item 2). Press seals lightly. *Note the direction of seal lip on drawing per Figure 1.*

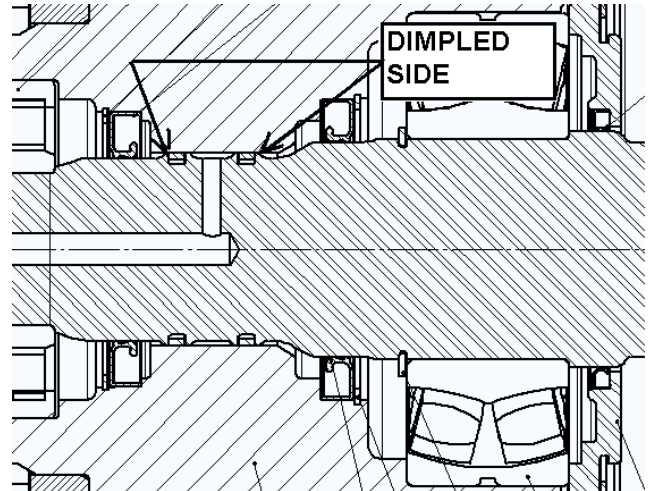

Figure 1

3. Apply Mobilfluid 424 oil or similar to seal lip (Items 16 & 12).
4. Install qty. of 2, retaining rings (Items 25, 24) and verify retaining rings are seated in grooves.

Shaft Assembly

1. Using bearing heater, heat I.D. of bearing (Item 13) to 250 °F. Using protective gloves, slide bearing onto shaft (Item 8) until it contacts the shoulder of shaft. See Figure 2.

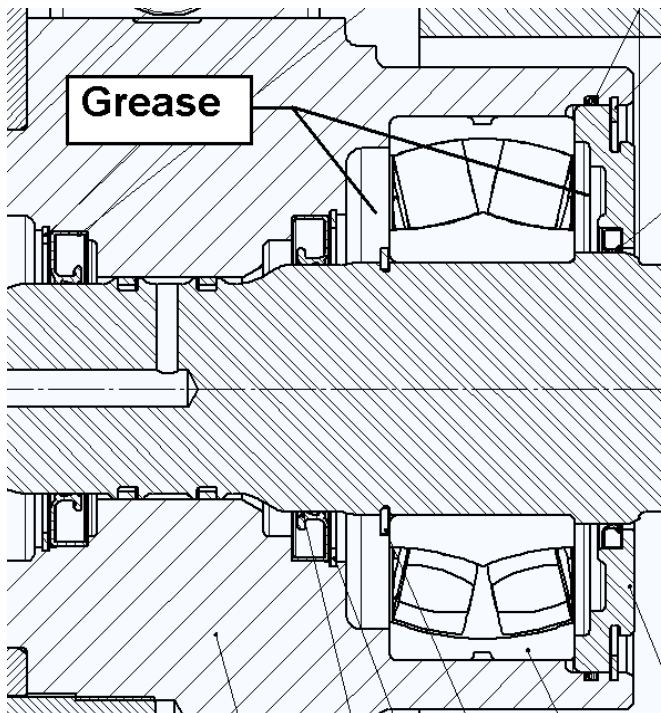

Figure 2

2. After bearing cools, use .002" feeler gauge to make certain bearing is seated and not cocked.
3. Install retaining ring (Item 26). Note: allow shaft to cool completely.
4. Carefully inspect hook piston rings (Item 5). **Piston rings need to be modified prior to installation. SEE CHYPR-008 DRAWING FOR PROPER MODIFICATION PROCEDURES.** *Clean piston rings prior to installation.*

5. Lube shaft diameter and hook piston rings with Mobilfluid 424 or similar oil.
6. Visually inspect piston ring grooves on shaft for any signs of contamination. Using hands install hook piston rings onto shaft in the configuration shown below and close hooks once the rings are installed on the shaft. **ATTENTION: the orientation of the dimpled side of the rings are extremely important. Spread rings just enough to get into groove.**

Endcover Sub-assembly

ATTENTION: Check for burrs or debris in bore of endcover at oil inlet and outlet holes.

1. Pack bearing (Item 13) on shaft with **MOBILITH SHC 220 grease only** to 20% capacity on outer bearing race.
2. Pack end of endcover with the retaining ring with **MOBILITH SHC 220 grease only** to 20% capacity on outer diameter. See figure 2 for location where grease should be packed during this step.
3. Lower end cover down over the shaft and hook piston rings. **ATTENTION: insure that hooked piston rings lead into the end cover with out binding. Insure that seal lip does not roll back during shaft installation.**

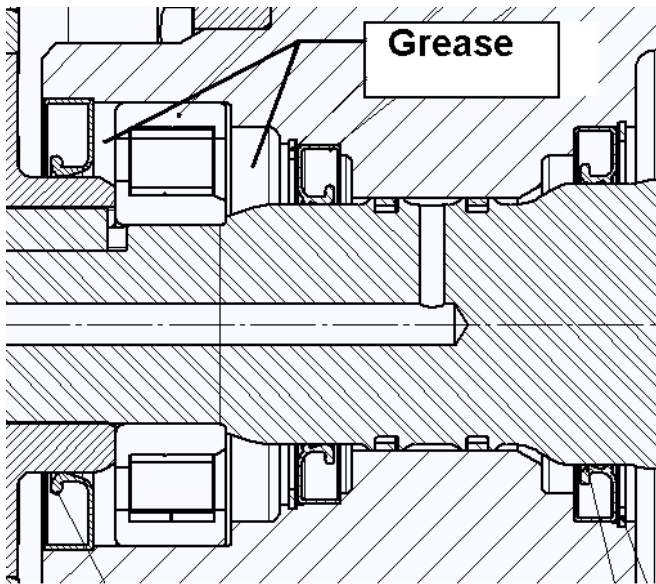

4. Pack end of endcover with **MOBILITH SHC 220 grease only**. Pack to 20% capacity on outer diameter. See sketch above for location where grease should be packed during this step.
5. Pack bearing (Item 13) **MOBILITH SHC 220 grease only** to 20% capacity on the outer bearing race.

Note: Bearing (Item 27) should have a shoulder on one side and no grease from factory. Using bearing press fixture install bearing and fixture over threaded rod and drawing bearing onto shaft using a hex nut on the threaded rod. Bearing will stop against shaft shoulder. **Important:** Install bearing with shoulder to outboard side (refer to drawing). Support housing to allow bearing to be pressed all the way down. Lightly tap on shaft until retaining ring groove is fully visible.

6. Lightly lube ID and OD of bearing with Mobilfluid 424 or similar oil. Thread 1/2-13 rod into shaft. Use a bearing press fixture that contacts the inner bearing race. Install bearing and fixture over threaded rod.
7. Draw bearing onto shaft using a hex nut on the threaded rod. Bearing will stop against retaining ring.
8. Insert key (Item 36) into keyway of shaft end.
9. **Important: Remove spring from seal and install seal (Item 28) lip facing out. Refer to drawing for proper orientation. Attention: do not over press.**

10. Install housing (Item 1) into endcover (Item 2). Install hex head bolts (Item 32) qty 9 and torque to PT Tech specification. Apply Loctite #262 to threads of bolt. Note: do not use any washers. **NOTE: orientation of housing to endcover as shown on assembly drawing.**

Note: do not use any washers. Note: orientation of housing to endcover as shown on assembly drawing.

Clutch Sub-assembly

1. Press dowel pin (Item 39) (short) qty 3 into end plate (Item 3), recessed section. Refer to drawing for proper orientation. Apply Loctite #609 to dowel pin before installing. Use pressing fixture. Dowel pin should be flush back surface of end plate.
2. Press dowel pin (Item 21) (long) qty 3 into end plate (Item 3). Refer to drawing for proper orientation. Apply Loctite #609 to dowel pin before installing. Use pressing fixture.
3. Align end plate (Item 3) with shaft and key. Use fixture and threaded rod to draw end plate onto shaft. Note: endplate will stop against bearing (Item 27). Apply Loctite #609 to endplate.
4. Remove the threaded rod from shaft end. **ATTENTION: Using flashlight insure that there are no metal burrs or chips inside threaded center hole of shaft after removing threaded rod.**
5. Install hex o-ring plug (Item 30) into shaft end and tighten until snug.

6. Install die springs (Item 41) qty 3 into end plate (Item 3).
7. Install friction plate (Item 6) into end plate. Note: friction plate will loosely pilot onto endplate step. **Note: friction surfaces must be free of oil and contamination.**
8. Install qty. of 3 (Item 42) springs into the counter bore holes in the end plate.
9. Install separator plate down into the short dowel pins (Item 7).
10. Install qty, of 3, shoulder bolts (Item 37) through the separator plate and into the end plate. **Use loctite #262 and torque bolts to 35 lb-ft.**
11. Install friction plate (Item 6) into end plate. Note: friction plate will loosely pilot onto piston step. **Note: friction surfaces must be free of oil and contamination.**
12. Lightly coat o-ring (Item 24) with Mobilfluid 424 oil and install into I.D. of groove piston (Item 9). Install piston (Item 9) into dowel pins of end plate (Item 3). **ATTENTION: do not pinch o-ring in I.D. groove of piston while installing over shaft.**
13. Lightly coat o-ring (Item 19) with Mobilfluid 424 or similar oil and install into O.D. groove in shaft (Item 8).
14. Lightly coat o-ring (Item 18) with Mobilfluid 424 or similar oil and install into O.D. groove in backplate (Item 14).

15. Install backplate (Item 14) over shaft end and into piston cavity. **ATTENTION: do not pinch o-ring in O.D. groove of fixed end plate and o-ring on shaft while installing.**
16. Install piston (Item 9) into dowel pins of endplate (Item 3). ***ATTENTION: do not pinch o-ring in I.D. groove of piston while installing over shaft.***
17. Using spanner wrench install clamp nut (Item 35) onto end of shaft. Tighten locknut until backplate (Item 14) stops moving.
18. Torque lockscrew on clamp nut (Item 35) to 70 lb-in.
19. Install o-ring (Item 40) into accumulator piston (Item 20) and insert into endcover.
20. Insert gray round wire spring (Item 23) into accumulator piston (Item 20) and endcover.
21. Install qty. of 4, hexhead capscrews (Item 46) p/n HHD08-06C36-XX and Manifold Assembly (Item 45) to the top of the endcover. Torque bolts to 47 lb-ft.
22. Follow Installation Instruction (at the beginning of this manual) for mounting the HPTO10TD to the engine.

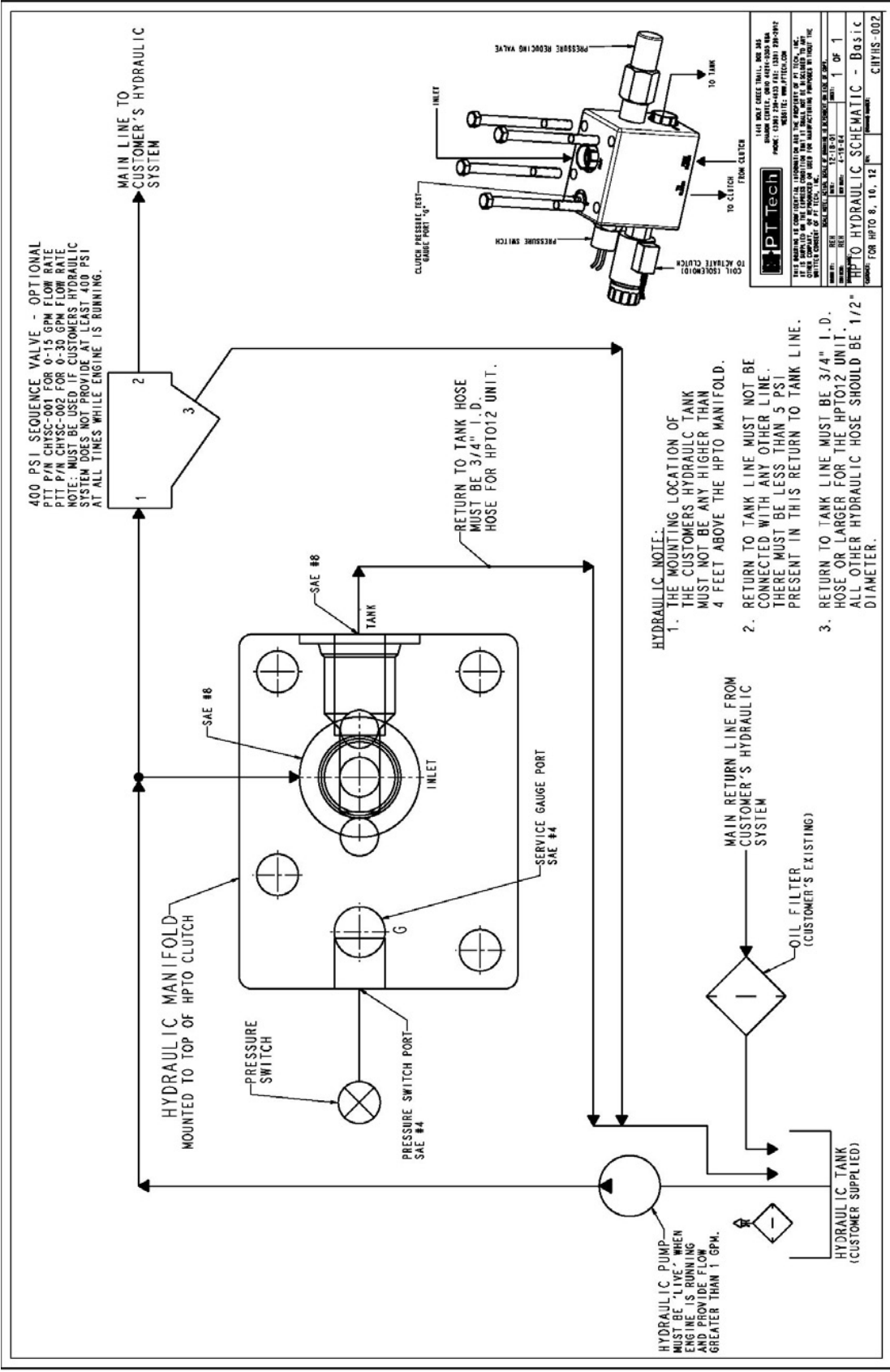

I & M BULLETIN
HPTO8TD-100
HYDRAULIC POWER TAKE-OFF

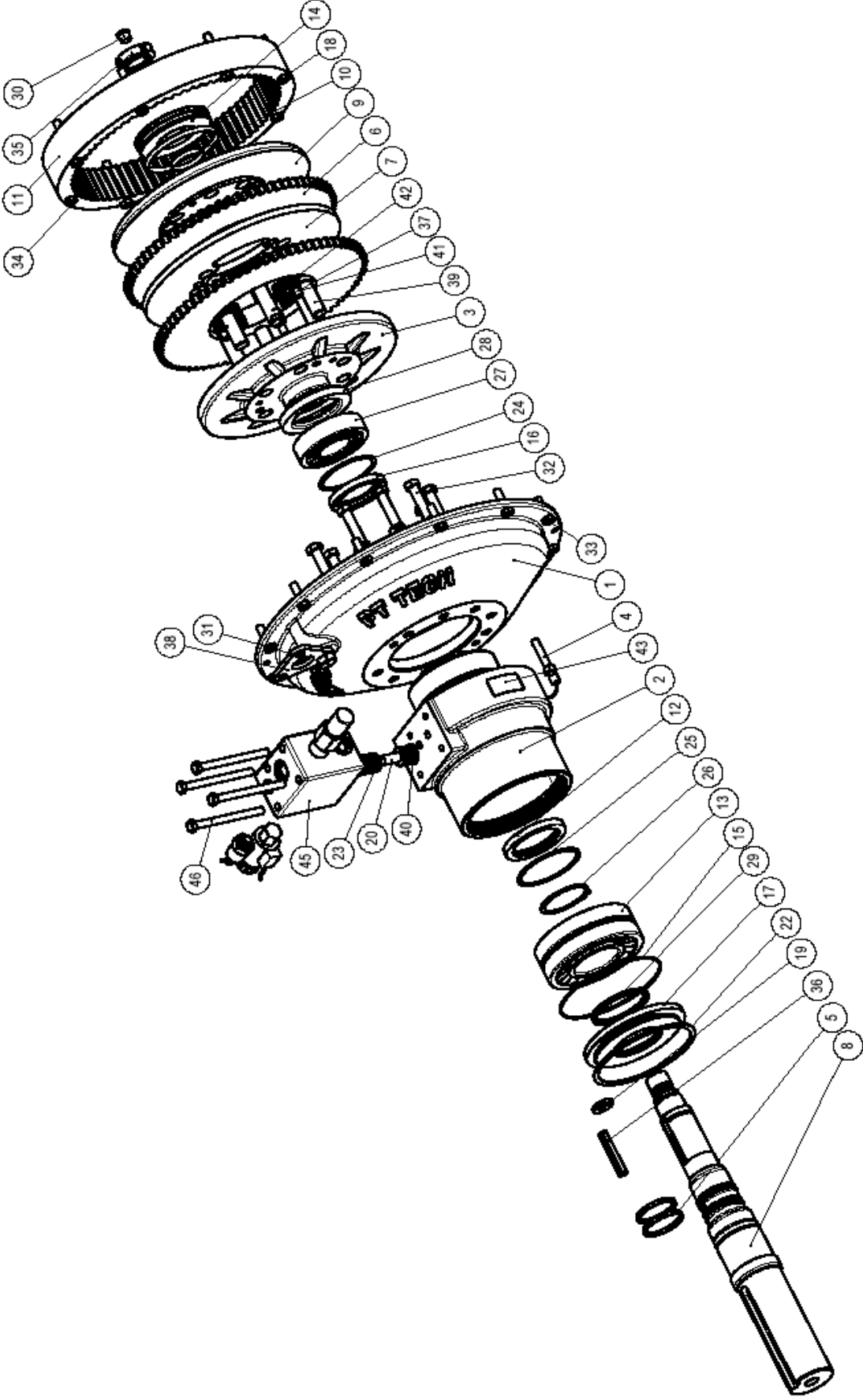

REVISION LOG SHEET

REV	DATE	INITIALS	CHANGES MADE
	5/7/03	moc	Newly created
A	9/4/03	BH	Updated controller callouts to match that of controller decal.
B	11/25/03	BH	Updated hydraulic schematic to callout 3/4" hose for HPTO12 unit.
C	12/29/03	BH	Removed controller documentation and created a separate controller I&M Bulletin.
D	1/26/04	BH	Added warning against plugging and pressurizing manifold drain port to lock down disc pack during installation.
E	4/19/04	BH/rr	Updated hydraulic schematic to add 3D view.
F	8/4/04	BH	Updated die spring to round wire spring in accumulator piston and updated accumulator piston to revision A per ECN 211.

TABLE OF CONTENTS

INSTALLATION INSTRUCTIONS	2
CONTROLLER FUNCTIONS	4
Power LED Indicator	4
<i>Engine Speed Detected LED Indicator</i>	4
<i>Clutch Engagement</i>	4
<i>Clutch Disengagement</i>	5
<i>FAULT – RPM TOO HIGH, while attempting to engage</i>	5
<i>FAULT – RPM TOO HIGH, while attempting to disengage</i>	5
<i>FAULT – TIMED LOCKOUT</i>	5
<i>FAULT – OIL PRESSURE Loss</i>	6
<i>FAULT – SAFETY SWITCH</i>	7
<i>FAULT – COIL FAULT</i>	7
<i>Remote Start Button</i>	7
OPERATING INSTRUCTIONS	9
TROUBLESHOOTING INSTRUCTIONS	10
<i>Power LED fault</i>	10
<i>Engine Speed Detected LED fault</i>	10
<i>Clutch will not engage</i>	11
<i>OIL PRESSURE</i>	11
<i>SAFETY SWITCH</i>	11
<i>COIL FAULT</i>	12
<i>RPM TOO HIGH, while disengaging</i>	12
<i>Clutch Disengages Unexpectedly</i>	12

Electronic equipment is potentially dangerous and should be installed by a trained professional. To avoid any electrical malfunction, the user should disconnect the wiring harness from the controller when welding on the equipment. Failure to do so may result in loss of controller warranty.

The **Microprocessor Controller** provides remote push button controlled clutch engagement of the HPTO. The controller is capable of monitoring clutch pressure, engine speed, and an equipment safety switch. The controller features an ISO standard symbol display with LED's that light to indicate system conditions.

INSTALLATION INSTRUCTIONS

Refer to the wiring diagram provided for all electrical connections. PT Tech can provide the wiring harness as an option to the customer. Contact PT Tech Sales for this part number. The customer must supply all electrical wire splice connectors.

1. The microprocessor controller must be connected to either a **12 or 24 Volt DC** power source (battery). **ATTENTION: there is either a 12 Volt or 24 Volt DC coil installed in the hydraulic manifold. The voltage markings of the coil MUST match the voltage of the system. If coil voltage does not match the voltage source, contact PT Tech prior to installation.**

ATTENTION: IN THE EVENT OF AN EQUIPMENT EMERGENCY E-STOP, POWER MUST STILL BE SUPPLIED TO THE CONTROLLER.

2. Install the 'zero crossing' speed pickup into the bottom of the clutch housing in the 3/8-16 UNF threaded hole. **ATTENTION: make sure there is a flywheel tooth directly centered in the hole. Then screw in the speed pickup until it stops, and then**

backed out 3 turns. While tightening locknut, make sure that the speed pickup does not move.

3. The **Manifold Assembly** has been preinstalled on the HPTO Clutch at the factory. Do not remove the manifold without consulting PT Tech. See *manifold drawing provided for hose fitting sizes and connection locations.*
4. Shielded wire must be used to connect the controller to the speed pickup located on the bottom of the HPTO bell housing. **ATTENTION: The shielded drain wire should be connected to the controller thru pin #11 only and not grounded or connected at the speed pickup.**
5. There are 3-dials on the back of the controller. These dials must be set to correctly match the tooth count of the flywheel ring gear. **Note: they should be preset at the factory to match the HPTO unit. If they are set at "000" then they must be changed prior to initial startup. See below for example.**

***HPTO 8 – has 72 teeth.
HPTO10 – has 72 teeth.
HPTO 12 – has 59 teeth.***

For 072 teeth, set the dials as follows:

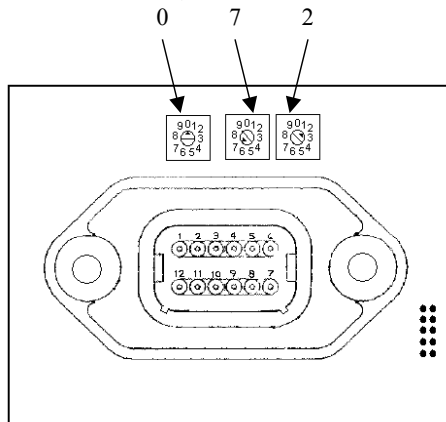

6. Install the **Microprocessor Controller** in a location in the customer's control panel that will provide visual accessibility. *The customer's control panel opening cutout, thru hole diameters and depth dimensions can be found on the controller mounting drawing at the end of this document.*
7. *Slide the controller through the opening in the machine's control panel.*
8. Connect the Deutsch 12-pin connector from the wiring harness to the back of the microprocessor controller.



WARNING: to avoid any electrical malfunction, the user should disconnect the wiring harness from the controller when welding on the equipment. Failure to do so may result in loss of controller warranty.

9. An optional remote engage/disengage button (customer provided) can be used, in addition to the button that is integrated on the front of the controller, to engage and disengage the clutch. *Refer to the Operating Instructions section of this manual.*

 **WARNING:** The controller has been pre-programmed at PT Tech per the customer's specifications. Failure to understand the specified operating parameters and conditions prior to initial startup and operation may result in unexpected results and/or possible damage to vital HPTO components. Contact PT Tech prior to initial startup to prevent possible injury and/or death.

CONTROLLER FUNCTIONS

Prior to initial startup of the system, it is important that the operator understand the following operational characteristics of the HPTO Clutch Controller.

IMPORTANT: The controller may not function properly if it receives a battery supply voltage below 8 volts DC. Insure that the machine battery is fully charged and provides 8+ volts while the engine is cranking.

The pre-programmed setting of the controller determines how the HPTO unit will function during startup. The following information describes the controller functions:

Power LED Indicator

The "Power LED" illuminates to notify the operator that the controller is receiving switched power from the engine ignition switch. See sketch below.

IMPORTANT: The engine ignition switch should be sending power to the controller in all switched positions except when the engine ignition switch is in the off position.

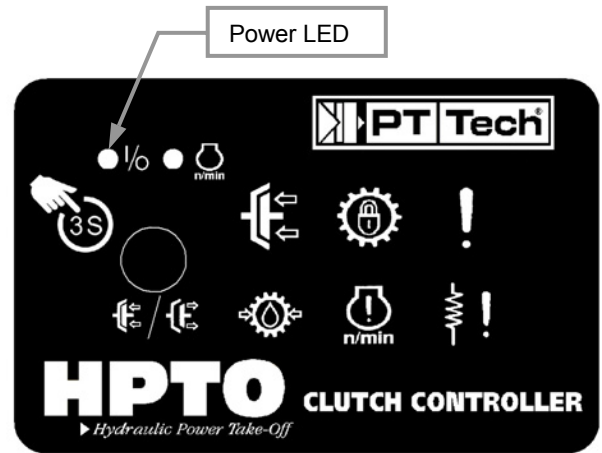

Engine Speed Detected LED Indicator

When the engine is running, the "ENGINE SPEED DETECTED" LED should be illuminated. See sketch below. This indicates that the controller is receiving a good signal from the speed pickup mounted at the bottom of the HPTO bell housing.

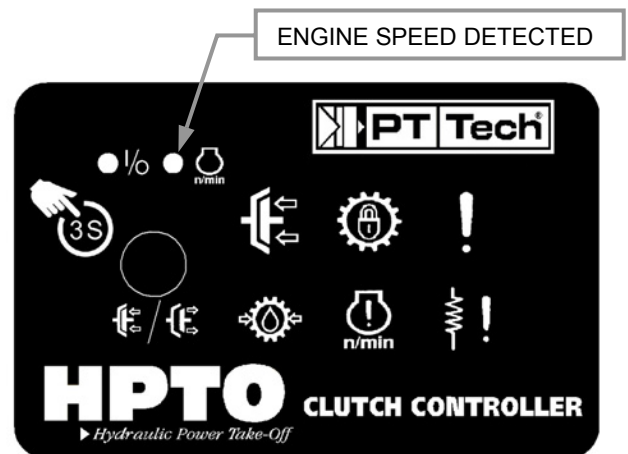

Clutch Engagement

To engage the clutch, the "Engage/Disengage Button" must be pressed for 3 seconds. Once the "CLUTCH ENGAGED" symbol illuminates, the button can be released. The controller will begin the engagement of the clutch and perform a series of "bumps" to bring the driven equipment up to engine speed.

During this time the “CLUTCH ENGAGED” symbol will illuminate to indicate that the clutch is engaging. See sketch below.

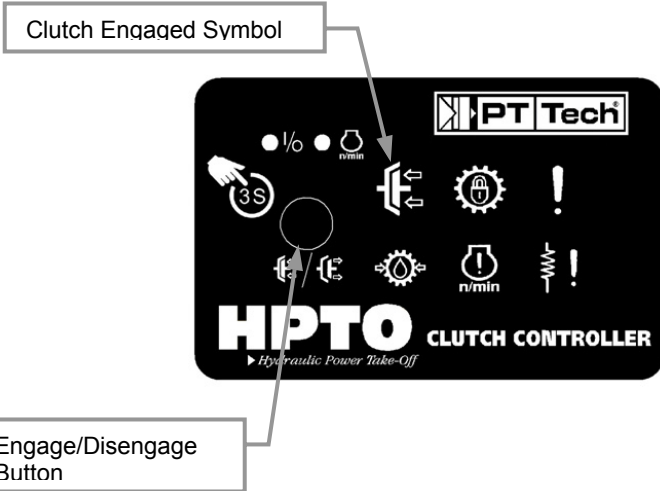

Clutch Disengagement

To disengage the clutch, push the “Engage/Disengage Button” and the clutch will immediately disengage. The “CLUTCH ENGAGED” symbol will not be illuminated.



FAULT – RPM TOO HIGH, while attempting to engage

The engine rpm must be below 1100 rpm to allow the clutch to engage. If the engine speed is above this limit while attempting to engage the clutch, the “RPM TOO HIGH” symbol will illuminate. See sketch below. Reduce engine speed below 1100 rpm and the light will turn off. Reattempt clutch engagement.

If, while the clutch is in the process of engaging (“bumping”), the operator intentionally increases engine speed, the engagement process will abort. The “CLUTCH ENGAGED” symbol will turn off and the “RPM TOO HIGH” symbol will FLASH to indicate that the engine speed was intentionally increased while the clutch was still “bumping”. (This is considered an

aborted startup attempt).

If the operator keeps the speed above 1100 rpm and re-attempts clutch engagement, then the “RPM TOO HIGH” symbol will turn on SOLID, indicating that the clutch is still over-speed. If the operator then lowers the speed below 1100 rpm then “RPM TOO HIGH” symbol will turn off.

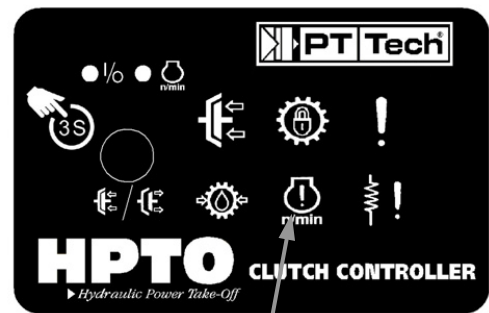

FAULT – RPM TOO HIGH, while attempting to disengage

The engine rpm must be below 1200 rpm to allow the clutch to disengage. If the engine speed is above this limit while attempting to disengage the clutch, the “RPM TOO HIGH” symbol will illuminate. See sketch below. Reduce engine speed below 1200 rpm and the light will turn off. Reattempt clutch disengagement.



FAULT – TIMED LOCKOUT

The controller will allow 3 failed clutch startup attempts in a row. After the 3rd failed clutch startup attempt, the controller will prevent the clutch from being engaged for 10 minutes. While the clutch is in lockout, the “TIMED LOCKOUT” symbol will illuminate to indicate that the clutch is in lockout and cannot be engaged. See sketch below.

Once the lockout timer has expired, the light will turn off and the clutch can be engaged.

ATTENTION: If engine ignition switched power is removed from the controller the lockout timer will continue to count down. If however the main battery power is disconnected from the controller, the lockout timer will stop counting down and restart once main power is supplied.

There are 3 different conditions that can take place, and thus be considered as “failed start attempts”. They are:

- While the clutch is engaging (“bumping”), the engine speed goes to zero and the engine stalls.
- If the operator attempts to increase engine speed while the clutch is engaging (“bumping”).
- If the operator pushes the engage/disengage button to disengage the clutch while the clutch is engaging (“bumping”).

Additionally, if the clutch (on the last bump) engages and stalls the engine (due to a locked rotor) the controller will go into immediate lockout regardless of how many “failed start attempts” have occurred.

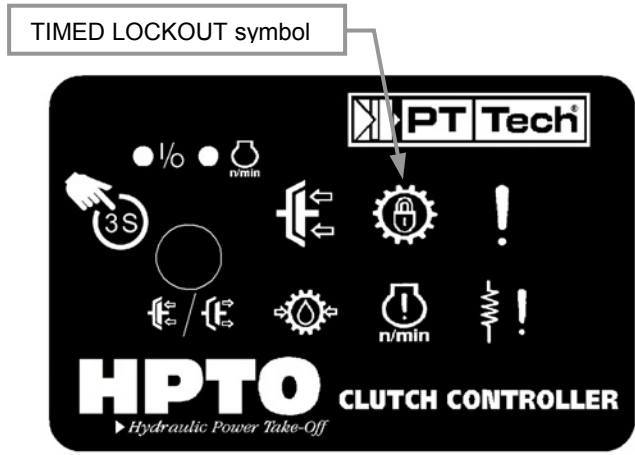

FAULT – OIL PRESSURE Loss

The Oil Pressure Switch is a **normally open** switch (*closes when pressure is acceptable*).

The controller monitors the clutch oil pressure with the clutch both engaged and disengaged.

If there is a pressure loss while the clutch is disengaged the “OIL PRESSURE” symbol will illuminate. *See sketch below.* The controller will not allow the clutch to be engaged. When oil pressure returns to normal, the light will turn off.

If there is a pressure loss while the clutch is engaged, the controller will disengage the clutch and the “OIL PRESSURE” symbol will FLASH to indicate that there was as pressure loss while the clutch was engaged. To clear this light, push and hold the “Engage/Disengage Button” for 3 seconds. If the oil pressure is back to normal the clutch will engage and the oil pressure light will turn off. If however, there is still a pressure problem, the light will illuminate steady.

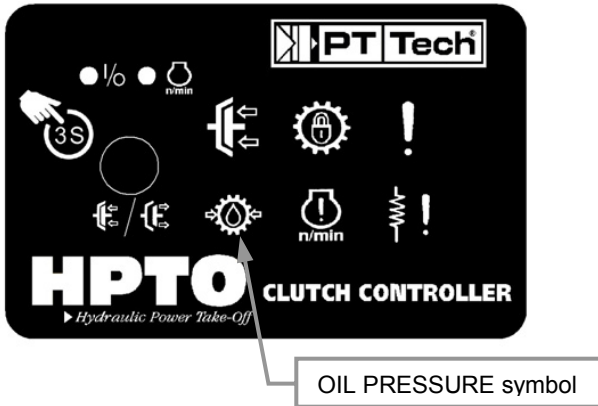

! FAULT – SAFETY SWITCH
 The Equipment Safety Switch (customer supplied) must be a **normally closed** switch (*opens when safety hazard exists*).

The controller can be wired to a switch on the customer’s equipment that, when open, will prevent the clutch from engaging. This switch could be attached to a tub cover, mill box, etc. When attempting to engage the clutch, the “SAFETY SWITCH” symbol will illuminate and prevent the clutch from engaging. Correct the safety hazard and the light will turn off. *See sketch below.*

! WARNING: Once the clutch is engaged, if this switch opens, the clutch will not disengage. This feature only prevents the clutch from engaging.

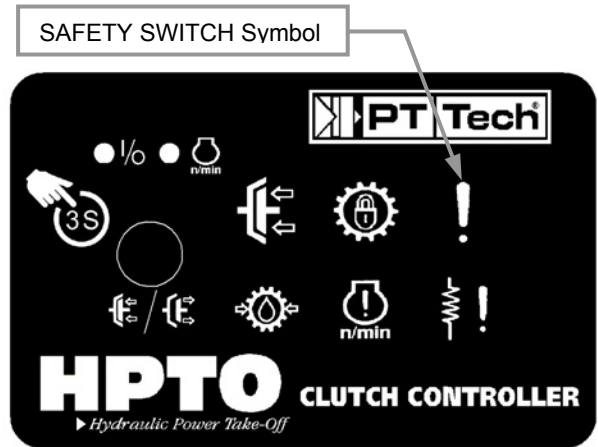

! FAULT – COIL FAULT
 Attached to the hydraulic manifold is a DC coil that controls the engagement and disengagement of the clutch. If this coil is either shorted or open when attempting to engage the clutch, the “COIL FAULT” symbol will illuminate. *See sketch below.* To get this light to turn off, fix the condition and reattempt clutch engagement.

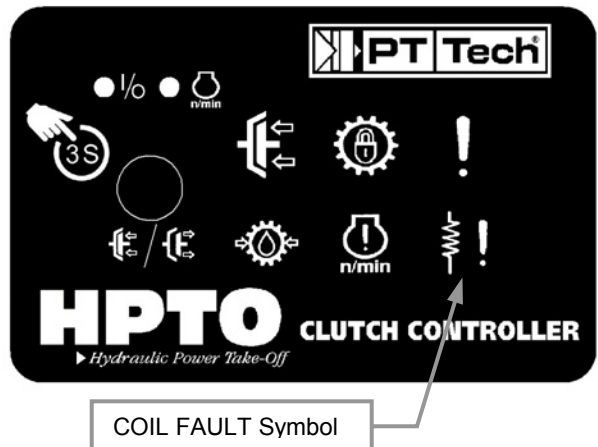

Remote Start Button
 A remote start button (momentary actuation required) can be attached to pin #5 of the controller. When a positive system voltage is applied to this pin, the controller will signal the clutch to engage or disengage. This remote start button will

cause the controller to function similarly to pushing the “Engage/Disengage Button” on the front of the controller. This remote switch must be a momentary switch only. The controller will draw the following amps when the remote button is pushed:

- @ 5volts the draw will be 10mA
- @ 12volts the draw will be 24mA
- @ 24volts the draw will be 48mA

Refer to the controller wiring harness drawing at the end of this document.

OPERATING INSTRUCTIONS

Once all of the installation instructions have been completed and the functionality of the controller has been understood, the system is ready for operation. The pre-programmed setting of the controller determines how the HPTO unit will function during startup.

If you feel that your operating conditions require a change to the pre-programmed controller settings, contact PT Tech, at 1-330-239-4933, to arrange for a field service technician.

The following operating instructions should be followed to provide optimum performance.

1. Turn the engine ignition to the run position. Note: The “Power LED” on the controller should illuminate. If the Power LED does not illuminate, refer to the Troubleshooting section of this manual.
2. Start the engine per manufacturer’s startup recommendations.
3. The “Engine Speed Detected” LED on the controller should illuminate while the engine is running. Note: If the “Engine Speed Detected” LED does not illuminate, refer to the Troubleshooting section of this manual.
4. Allow the engine to run at idle speed, for a sustained period of time, to allow the hydraulic oil to reach a normal running temperature prior to engaging the HPTO Clutch.
5. To engage the clutch of the HPTO unit, push and hold the “Engage/Disengage Button” (start button) for **3 seconds**.

Once the “CLUTCH ENGAGED” symbol illuminates, the button can be released. *Note: The controller will begin the engagement of the clutch and perform a series of “bumps” to engage the clutch and bring the driven equipment up to engine speed. During this time the “CLUTCH ENGAGED” symbol will illuminate to indicate that the clutch is engaging.*



WARNING: Clutch should engage immediately after the “CLUTCH ENGAGED” LED illuminates.

If the clutch does not engage, note the condition of the controller display symbols and refer to the Troubleshooting section of this manual.

6. To disengage the clutch of the HPTO unit, press the “Engage/Disengage Button” a second time while the engine is at idle speed. An alternative preferred method for disengaging the clutch would be to power down the engine to a stop by simply shutting off the engine ignition switch. The clutch of the HPTO unit will automatically disengage once the engine has reached zero speed.

TROUBLESHOOTING INSTRUCTIONS

The following items may be helpful in determining what caused the various symbols to illuminate on the controller display.

Power LED fault

The “Power LED” should be illuminated when the Engine Ignition Switch/Key is in every position other than the OFF position. If this is not the case, check the following items:

- ❑ With the Engine Ignition Key in every position (other than OFF) check the wire connected to pin 7 on the back of the controller for voltage. If no voltage is found, check for a cut wire or check Engine Ignition Key terminal connections.
- ❑ Check that the wire connected to pin 1 on the back of the controller is connected directly to the positive (+) terminal of the battery with no break in the wire.
- ❑ Check that the wire connected to pin 2 on the back of the controller is connected directly to the negative (-) terminal of the battery with no break in the wire.
- ❑ Check that the wire connected to pin 7 on the back of the controller is not losing momentary power while the engine is cranking.



Engine Speed Detected LED fault

While the engine is running the “Engine Speed Detected” LED must be illuminated. If this is not the case, check the following items:

- ❑ Check that the 3-dials on the back of the controller are set correctly to match the tooth count of the flywheel ring gear.

HPTO 8 – has 72 teeth.

HPTO10- has 72 teeth.

HPTO 12 – has 59 teeth.

For 072 teeth, set the dials as follows:

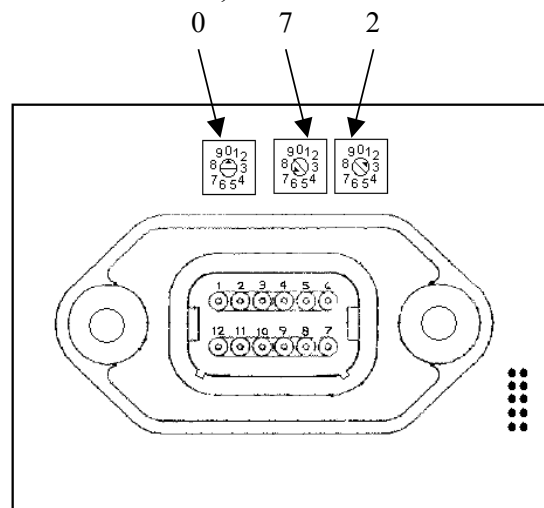

- ❑ Check the speed pickup that is installed in the bottom of the HPTO bell housing. Align a flywheel tooth directly centered in the bell housing hole and then screw in the speed pickup until it stops, then back out 3 turns. While tightening locknut, make sure that the speed pickup does not move.
- ❑ Check the wire running from the speed pickup to the back of the controller to insure that the wire is not cut. **This wire must be shielded wire.**
- ❑ Check that the bare metal wire (drain) is connected at pin 11 on the controller and **NOT** connected at the speed pickup end.
- ❑ Remove speed pickup and check

probe end to make certain it is not damaged.

- ❑ Replace speed pickup with a new one.



Clutch will not engage

After pushing and holding the “Engage/Disengage Button” (start button) for 3 seconds, the clutch will not engage. If the clutch will not engage, check the following items:

- ❑ Check that the voltage stamped on the side of the coil (either 12 or 24 volts) matches that of the equipments voltage supply. ***The stampings on the side of the coil MUST match the equipments voltage source.***
- ❑ The Power LED and the Engine LED must be illuminated. If not, the clutch will not engage. *Refer to those sections of the Troubleshooting section of this manual.*
- ❑ The controller must be receiving a minimum of 8 volts DC from the positive terminal of the battery to pin 1 on the back of the controller. While cranking the engine, if the machine battery is not fully charged, the voltage may drop below 8 volts and cause the controller to behave erratically.



OIL PRESSURE

Check the following items:

- ❑ Check all hoses for leaks.

- ❑ Check reservoir fluid level.
- ❑ Check oil filter.
- ❑ Check cooler for a leak.
- ❑ Check pressure switch wires for a cut wire.
- ❑ Install a pressure gauge with an SAE #4 o-ring fitting into the manifold at the location stamped “G”. On the pressure switch in the manifold, locate the pressure setting stamped on the pressure switch. With the engine running, and the clutch either engaged or disengaged, the dial on the pressure gauge should read approximately 15psi higher than the pressure switch setting. If this condition is true then there is either a pressure switch problem or a wiring problem.
- ❑ With the pressure gauge connected and the engine running, check for continuity across the two pressure switch leads. If the pressure gauge indicates that the pressure is good but there is no continuity across the pressure switch leads, then the pressure switch may be bad.



SAFETY SWITCH

Check the following items:

- ❑ Trace the wire from pin 9 at the back of the controller to the safety switch on the equipment. If no safety switch is present, then the wire connected to the controller at pin 9 must be receiving system power when the controller is powered on.

- ❑ If a safety switch is present, insure that it is receiving power and in good working order.
- ❑ Check that the wire connected to pin 9 at the controller is not cut.



COIL FAULT

Check the following items:

- ❑ Check that the wires from pins 3 & 4 are neither cut or grounded, nor connected together, thus creating a dead short.
- ❑ Check that the voltage stamped on the side of the coil (either 12 or 24 volts) matches that of the equipments voltage supply. ***The stampings on the side of the coil MUST match the equipments voltage source.***
- ❑ Make sure pin 3 & 4 wires are pushed all of the way into the connector at the back of the controller.
- ❑ Use an Ohm Meter and measure the resistance between the two coil wires at the coil. ***The two wires at the controller may need to be cut in order to take this measurement.***

The Ohm readings should be as follows:

12 volt coil = 6.4 ohms +/- 1 ohm

24 volt coil = 29.3 ohms +/- 1 ohm



RPM TOO HIGH, while disengaging

If the actual speed of the engine is well below the minimum 1200 rpm speed that the controller is requiring, yet the "RPM

TOO HIGH" symbol is illuminated when the "Engage/Disengage Button" is pressed, then refer to the Troubleshooting section titled, "Engine Speed Detected" LED Fault.

Clutch Disengages Unexpectedly

The controller will automatically disengage the clutch for two reasons.

First, if there is a pressure fault while the clutch is engaged. See "Controller Functions" section.

Second, if the controller loses a signal from the engine speed pickup. See the Troubleshooting section titled, "Engine Speed Detected" LED Fault".

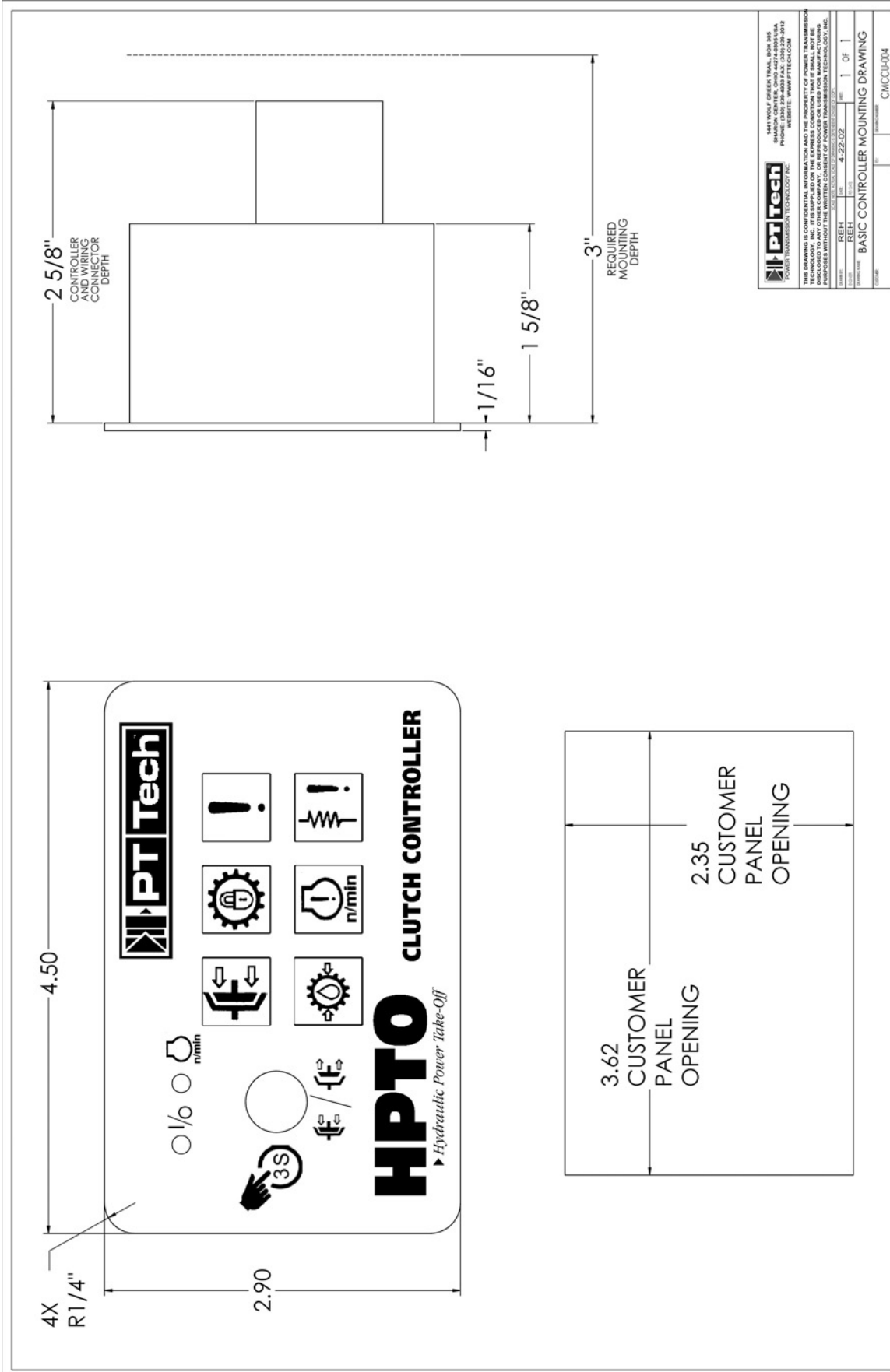

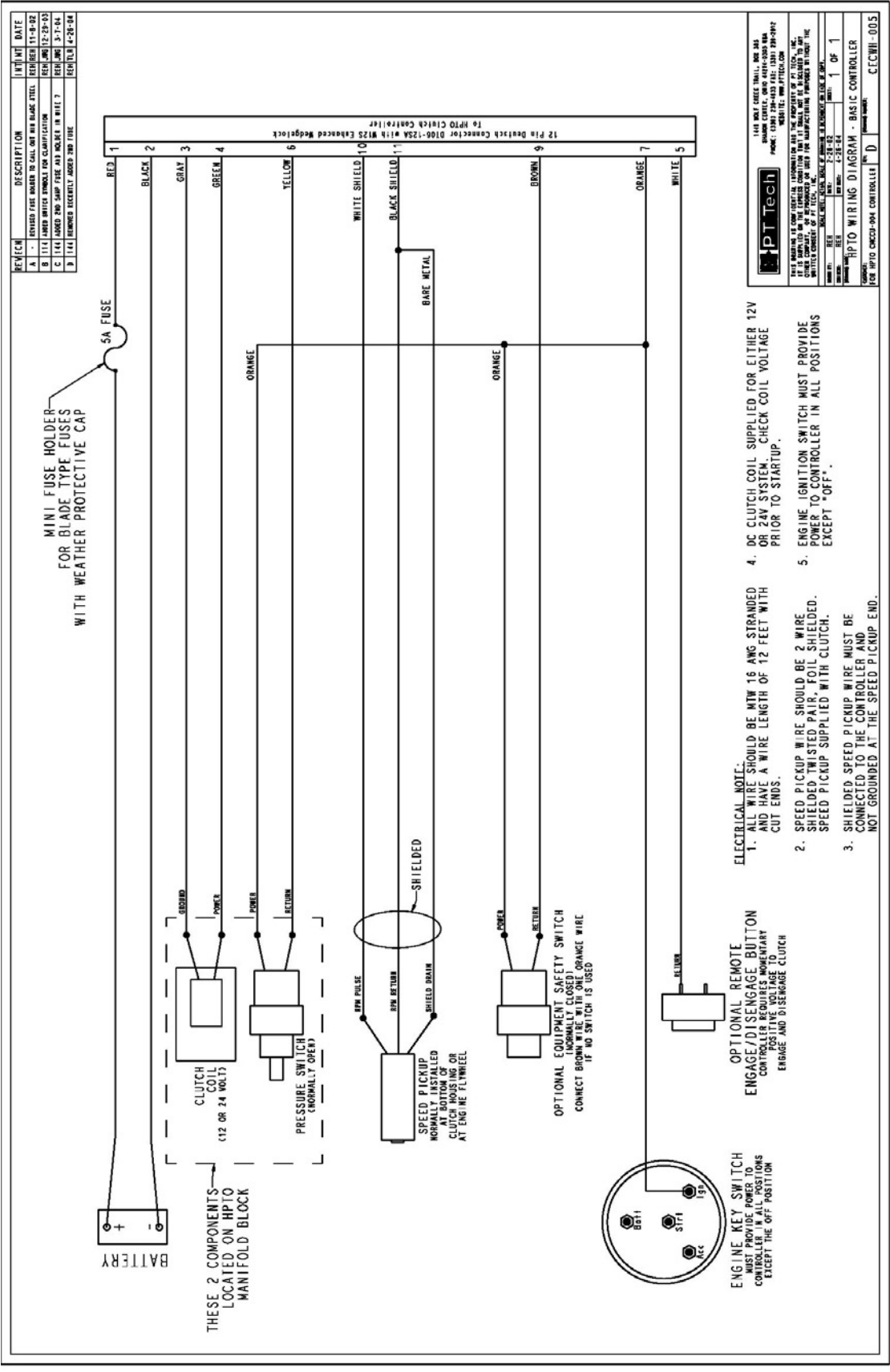

REVISION LOG SHEET

REV	DATE	INITIALS	CHANGES MADE
	12/29/03	BH	Newly created in word.
A	3/7/04	BH	Updated wiring harness schematic per ECN# 144.
B	3/12/04	BH	Added coil ohm measurement to coil fault troubleshooting section.
C	4/26/04	BH	Updated wiring harness schematic.
D	4/27/04	BH	Updated controller images to black face style.
E	11/17/04	BH	Added functionality of immediate lockout on last bump if engine stalls. Also clarified what keeps the lockout timer counting down.



OMNEX
TRUSTED WIRELESS

J.P. Carlton Hurricane II Stump Cutter

Installation / Configuration Manual

T300 Transmitter

R160 Receiver

D180 Expansion Module

May 03, 2006

DM-R160-0228A

Revision 1

This page is intentionally left blank.

Table of Contents

System Overview	4
Features.....	4
T300 Dimensions and Controls	4
Installing the Receiver	5
Receiver Dimensions.....	5
Installing the Expansion Module.....	6
Special Functions	6
Installation Considerations.....	7
Power the Transmitter	7
Test the Transmitter / Receiver Link.....	8
Download ID Code.....	8
Diagnostics—T300 Transmitter	10
Diagnostics—D180 Expansion Module	10
Diagnostics—R160 Receiver.....	11
Trouble Shooting Guide.....	12
Parts & Accessories.....	16
Specifications.....	16
Warranty Information	16

NOTE: These instructions are intended only for installing and operating the remote control equipment described here. This is not a complete Operator's Manual. For complete operating instructions, please read the Operator's Manual appropriate for your particular machine.

Safety Precautions

READ ALL INSTRUCTIONS

CAUTION: Changes or modifications not expressly approved by the party responsible for compliance could void the user's authority to operate the equipment.

Failure to follow the SAFETY PRECAUTIONS may result in radio equipment failure and serious personal injury

Installation

PROVIDE A SAFETY CUTOFF SWITCH. If maintenance is required, the radio must be disconnected from power

USE PROPER WIRING. Loose or frayed wires can cause system failure, intermittent operation, machine damage, etc.

DO NOT INSTALL IN HOT AREAS. This apparatus can be damaged by heat in excess of 158°F (70°C)

Personal Safety

MAKE SURE MACHINERY AND SURROUNDING AREA IS CLEAR BEFORE OPERATING. Do not activate the remote system unless it is safe to do so.

TURN OFF THE RECEIVER POWER BEFORE WORKING ON MACHINERY. Always disconnect the remote system before doing any maintenance to prevent accidental operation of the machine

Care

KEEP DRY. Do not clean the transmitter / receiver under high pressure. If water or other liquids get inside the transmitter battery or receiver compartment, immediately dry the unit. Remove the case and let the unit air dry

CLEAN THE UNIT AFTER OPERATION. Remove any mud, dirt, concrete, etc. from the unit to prevent clogging of buttons, switches, etc. by using a damp cloth.

Maintenance / Welding

DISCONNECT THE RADIO RECEIVER BEFORE WELDING on this machine. Failure to disconnect will result in the destruction of the radio receiver.

System Overview

The **ORIGA T300 / R160 / D180** is a portable, long range, programmable radio remote control system. Designed as a compact and easy-to-use product, this member of the **ORIGA** family puts complete control of your crane where it's needed most, with the operator. It's robust, easy to install and has complete self-diagnostics. This system can be a simple cable replacement or add intelligence to make it a total control package. It's a radio, a PLC and a valve driver all in one.

The **ORIGA T300 R160 / D180** system uses Frequency Hopping Spread Spectrum (FHSS) technology. FHSS devices concentrate their full power into a very narrow signal that randomly hops from frequency to frequency within a designated band. This transmission pattern, along with CRC-16 error-checking techniques, enables signals to overcome interference that commonly affects licensed radios.

The **R160 receiver** is designed to be powered from a 12VDC or 24VDC system. It features 19 solid state, high-side driver input / output controls and a reliable E-Stop control.

The D180 Expansion Unit has up to fourteen current-control, PWM, or voltage outputs, or a combination of these types.

The **T300 transmitter** comes with up to sixteen proportional and sixteen digital controls. The T300 can accommodate up to eight single axis paddles, eight three-position switches and a re-settable E-Stop. A unique ID code is used by each T300 to ensure that no two systems will conflict on a job site.

Features

- FCC, ISC, CE approved
- License free
- 1200 foot range @ 900 MHz (900 ft @ 2.4 GHz)
- Compact / weatherproof / ergonomic
- Simple "wire-and-use" installation
- Resilient to impact and shock
- Available in both 900 MHz and 2.4 GHz
- Available with paddles and/or joysticks for proportional control
- Available with an optional pendant cable
- Factory configurable for all custom applications.



T300 Dimensions and Controls

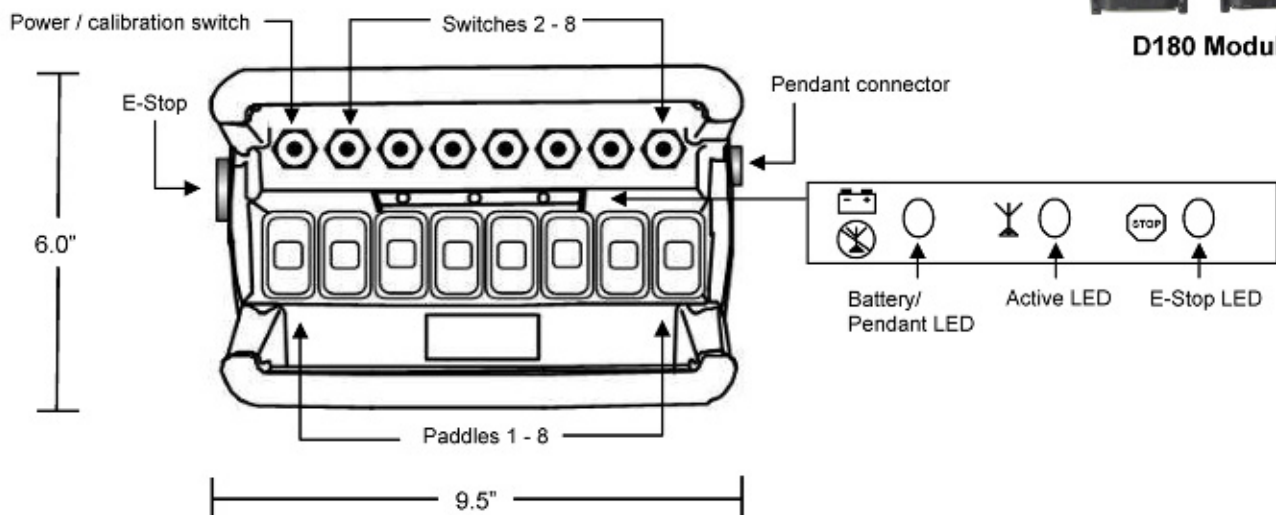

Installing the Receiver

Use the **Wiring Diagram** and the **Connector Diagram** below to connect the receiver pins directly to the appropriate contacts of the machine electronics. R160 Output Cables can be provided with every system to simplify the wiring process. The Wire Color column below only applies to the OMNEX Output Cable configuration. Tips on mounting, power connections and filtering are also provided under **Installation Considerations**.

Wiring Diagram

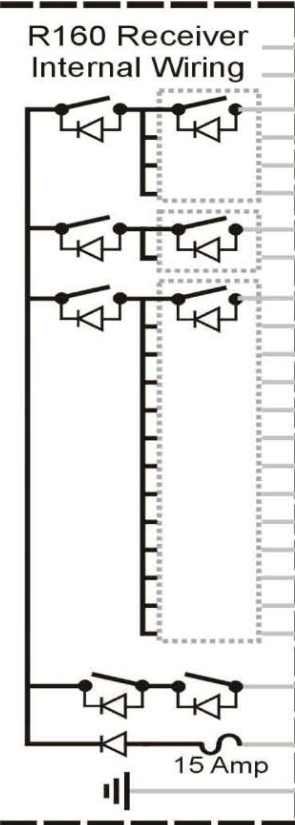

Pin-Output	Wire Colors	Functions	Notes
B7		RS-485 COM	
B8		RS-485 COM	
B12 - 19	Black/Red	Swing Left/Right	
B11 - 18	White/Black	Head Down/Up	
B10 - 17	Blue/White	Not used	
A1 - 16	Blue/Black	Not used	
A2 - 15	Black/White	Right Track Reverse/Forward	
A4 - 14	Green/Black	Left Track Reverse/Forward	
B9 - 13	Red/White	Not used	
B6 - 12	Orange	Not used	
B5 - 11	White	Not used	
B4 - 10	Green/Black/White	Not used	
B3 - 9	Green	Not used	
B2 - 8	Red/Black/White	Not used	
B1 - 7	White/Red/Black	Not used	
A12 - 6	Orange/Red	Not used	
A10 - 5	Orange/Black	Swing Release	
A11 - 4	Blue/Red	Clutch Engage/Disengage	
A9 - 3	White/Red	Gear High	
A8 - 2	Red/Green	Throttle Down	
A7 - 1	Orange/Green	Throttle Up	
A5	Black/White/Red	Switches to Power with Link	Note: Outputs 14, 15, 18, 19 are voltage proportional.
A6	Red	Power Input (+9V to 30VDC)	
A3	Black	Ground	

Outputs: 19 solid state, high-side driver outputs, 5A max. each, total combined current 15A
Inputs: All output pins can be factory configured as inputs.

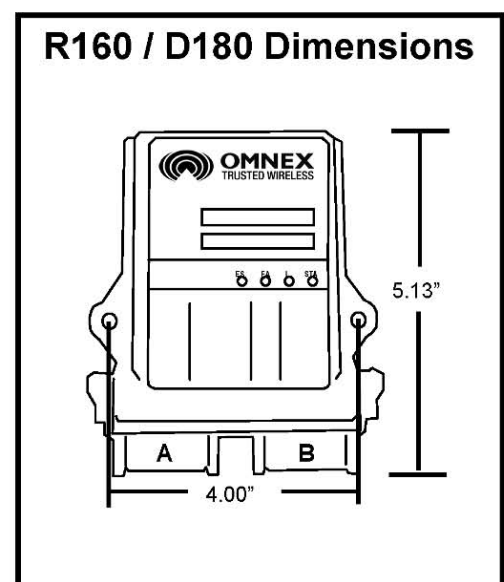
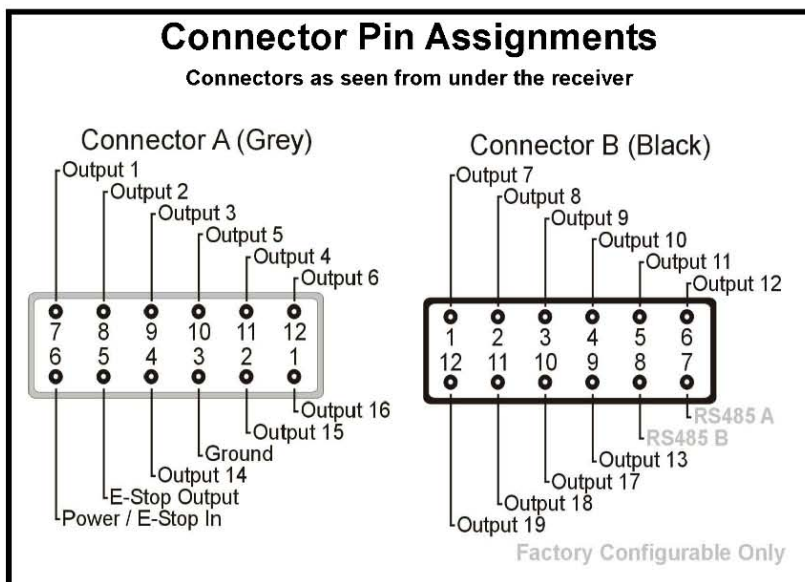

Installing the Expansion Module

Use the **Wiring Diagram** and the **Connector Diagram** below to connect the Expansion module pins directly to the appropriate contacts of the machine electronics. D180 Output Cables are provided with every system to simplify the wiring process. The Wire Color column below only applies to the OMNEX Output Cable configuration. Tips on mounting, power connections and filtering are also provided under **Installation Considerations**.

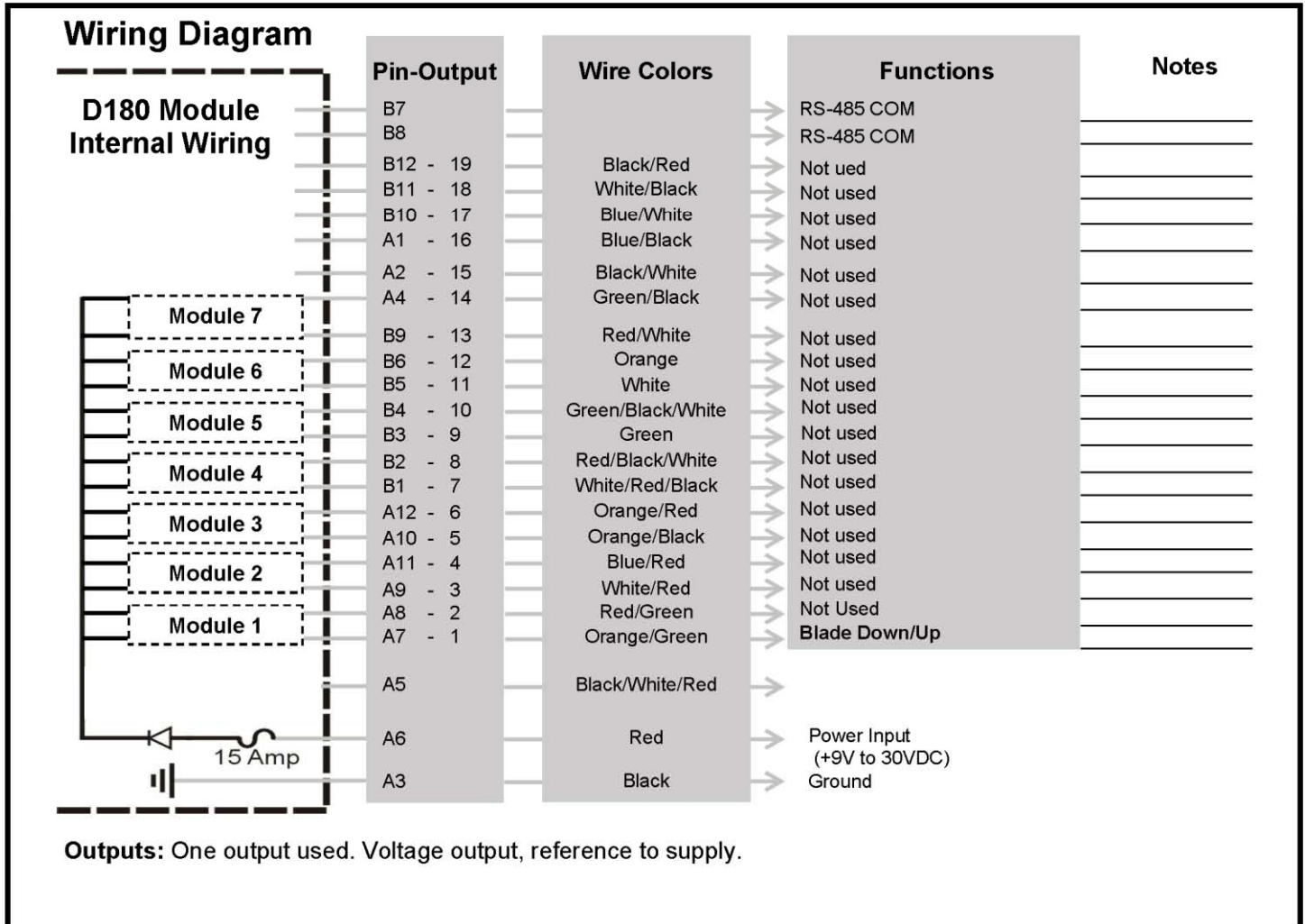

Special Functions

The full voltage range for all proportional outputs is 25%-75% of the supply voltage, with 50% as the middle (neutral) point. With 12V supply that gives range 3V-9V with 6V as the mid-point.

The High Speed mode uses 100% of the range.

The Low Speed mode uses 80% of the full range, with 12V supply that gives range 3.6V-8.4V

The Creep Speed mode used 65% of the full range, with 12V supply that gives range of 4.05V-8.05V

The **SWING** Speed potentiometer control allows the operator to vary the maximum and minimum voltage output controlled by the Swing paddle

For all proportional controls (except **SWING**), pushing a paddle away from the operator gives the output voltage above mid-point. Pulling a paddle towards the operator gives the output voltage below mid-point. For the **SWING** paddle the converse to the above is true.

The **NEUTRAL TRACKS** control is applied to the track outputs only when they are operated by the **BOTH TRACKS** paddle.

The **GEAR HIGH/LOW** digital function is operated by the paddle. The output latches when paddle is pushed to **HIGH**, and it unlatches when the paddle is pulled to **LOW**.

Installation Considerations

Mounting and Installation

The receiver can be mounted by fastening two ¼" bolts through the two mounting holes in the unit's enclosure. When mounting, ensure that the receiver is oriented so that the text is reading right.

When selecting a mounting point for the receiver, it is recommended that the location require only a minimal length of wiring to connect it to the control panel, that it will be in a visible area where it has good exposure to the operator and that it is mounted on a surface that is protected from the weather and sustains minimal vibration. It is also recommended that the receiver have the best possible line of sight with the transmitter.

Power Connections and Wiring

Whenever a power connection is made to an electronic device, it is a good practice to make both the Power (+) and Ground (-) connections directly to the Battery and avoid connecting the power from the charging side of existing wiring or making use of existing "ACC" or other peripheral connection points.

Make sure that wire of sufficient gauge and insulator type is used when connecting the outputs of the receiver to the control panel. Observe any component manufacturer's instructions and recommendations for proper integration of their product. This includes the power ratings and requirements of such components as relays, valves, solenoids, etc.

Be sure to test each of the outputs with a multi-meter prior to connecting the outputs to your end devices. This will ensure that each output has been programmed to operate in the manner required by each end device.

Filtering and Noise Suppression

Whenever a solenoid or electromagnetic switch is controlled by the receiver, it is a good practice to install a Diode across its terminals to ensure that surges and spikes do not continue back into the circuit. Appropriate 36V Bi-directional Diodes kits can be ordered under the OMNEX part number "AKIT-2492-01".

Power the Transmitter

1. Install the batteries in the transmitter

Batteries are installed in the transmitter by removing the battery cover using a slotted screwdriver and inserting 4 "C" alkaline batteries. Orientation of the batteries is embossed inside the battery housing. No batteries are required when the transmitter is connected to the receiver by a Pendant cable.

NOTE: For operation at temperatures below -10° C to -40° C, lithium batteries are recommended. Low temperatures reduce battery performance for both alkaline and lithium types. Refer to the battery manufacturer's specifications for detailed information on low temperature performance.

2. Turn on the transmitter

Ensure all transmitter switches and paddles are in the neutral position. (**NOTE: the neutral position for the SWING switch is on LOCK**) Turn on the transmitter by pressing and releasing the [Power] switch. The RED (E Stop) light will flash quickly. Release the [E Stop], the yellow (Active) light on the transmitter will flash.

WARNING: do not install batteries backwards, charge, put in fire, or mix with other battery types. May explode or leak causing injury. **Replace all batteries at the same time as a fresh set and do not mix and match battery types.**



Transmitter Battery Housing

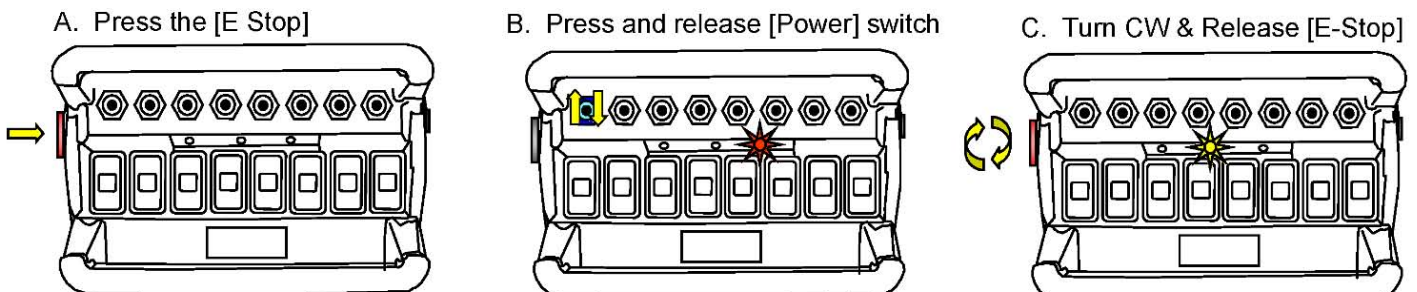

Light Legend	Solid	Slow Flash	Fast Flash	Red Light	Green Light	Yellow Light	Alternating Red & Green Light
							

Test the Transmitter / Receiver Link

Follow these steps to ensure that there is a Radio Link between the transmitter and receiver

Refer to the Light Legend below for diagram details

1. Press [E-Stop]

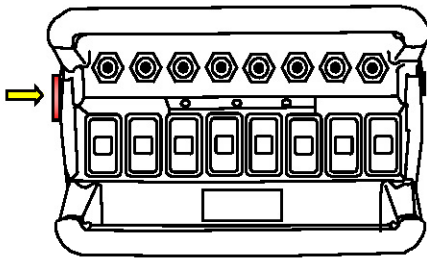

2. Power the R160

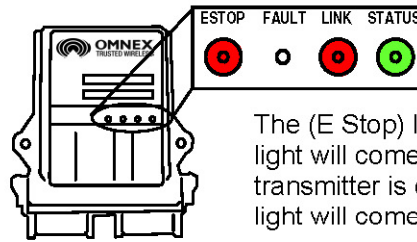

The (E Stop) light and the (Link) light will come on RED (provided the transmitter is off), and the (Status) light will come on GREEN.

3. Power the T300

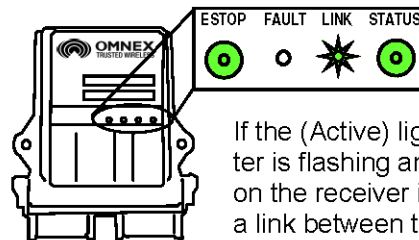
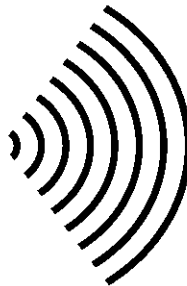
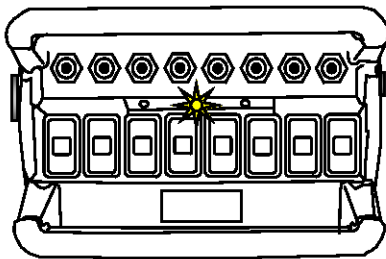

If the (Active) light on the transmitter is flashing and the (Link) light on the receiver is flashing GREEN, a link between the two exists.

NOTE: The transmitter will shut itself off (and the receiver will then shut off all outputs) after 4 hours of inactivity as a battery saving feature. To restart the timer before the transmitter shuts off automatically, momentarily operate any toggle switch or paddle.

The ORIGA System is now ready for use.

If the receiver's (Link) light does not become GREEN follow the steps under **Download ID Code**.

Download ID Code (Use in case of Link Test failure)

Follow these steps to download the transmitter's unique ID Code into the receiver. This will allow the receiver to establish a Radio link with a specific transmitter. Refer to **Trouble Shooting Chart #4** for Tips and Considerations

NOTE: It is necessary to download the ID code when replacing either the transmitter or the receiver.

NOTE: If the transmitter is connected to the receiver with a Tether Cable, completing **only steps 4 and 6** is necessary (it is not necessary to open the R160 case and press the Setup button).

1. Opening the R160 Case

The cap is held on by two plastic tabs at opposing sides, which can be unlatched as shown using a screwdriver. Once the cap is free, the R160 can slide open.

Use a small slotted screwdriver to press the Side Tabs inward.

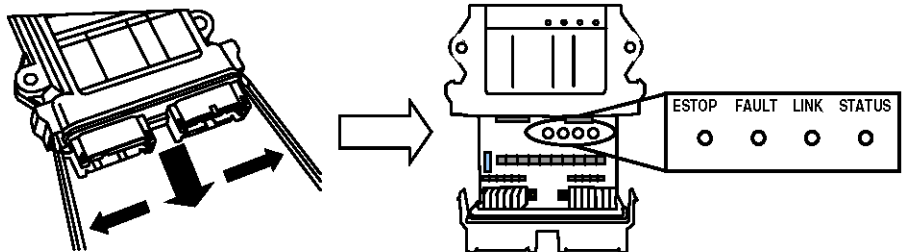

Light Legend

Solid		Slow Flash		Fast Flash		Red Light		Green Light		Yellow Light		Alternating Red & Green Light	
-------	--	------------	--	------------	--	-----------	--	-------------	--	--------------	--	-------------------------------	--

2. Prepare T300

- Press [E-Stop]
- Twist CW & release [E-Stop]

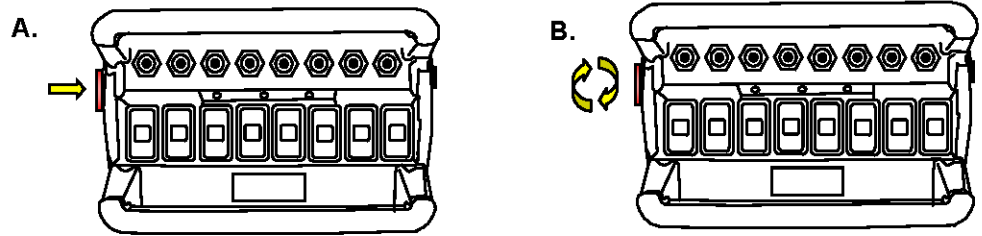

3. Power R160

- Supply power to the receiver. The (E-Stop) light and the (Link) light will come on RED and the (Status) light will come on GREEN

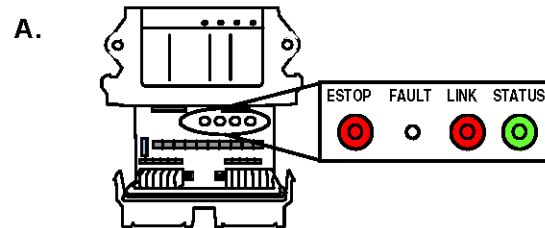

4. Power T300 into Configuration Mode

- Hold [Power] switch UP
- Press [E-Stop]
- Twist CW & release [E-Stop]
- Release [Power] Switch

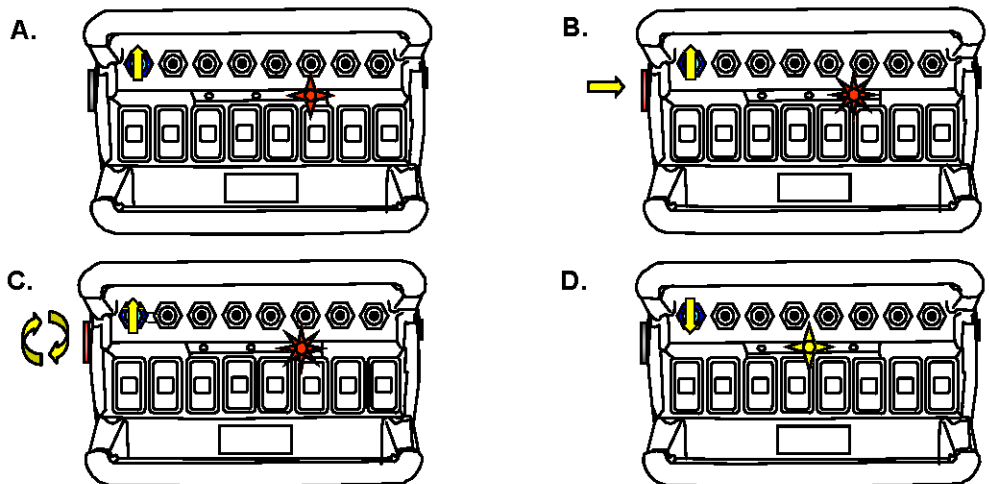

5. Put R160 into Setup Mode

- Press & hold [Setup] button until (Status) light goes from slow flash to fast flash
- Release [Setup] button. (Status) light goes to solid GREEN, (Link) light turns off

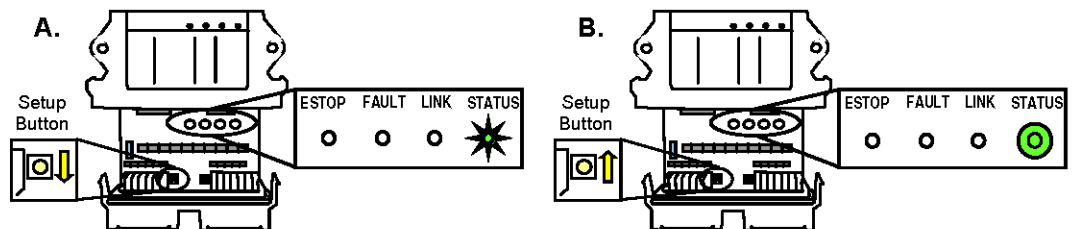

NOTE: If left idle in Setup Mode for over 30 seconds, the receiver will time out. The (Link) light and (Status) light will flash RED rapidly. To return to Setup Mode, repeat step 4.





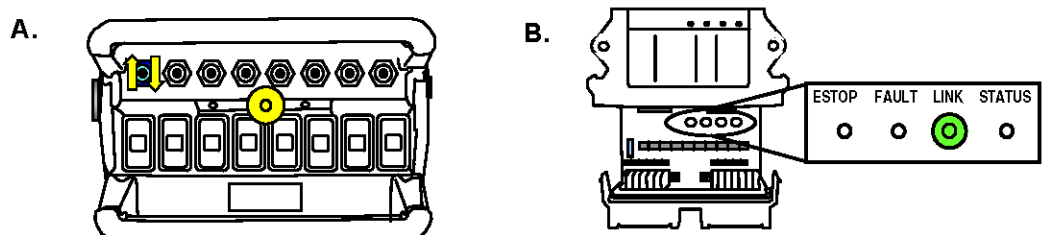

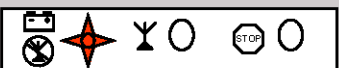
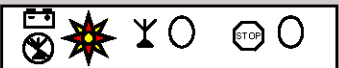

6. Download ID Code

- Press [Power] switch UP and release
- (Link) light goes to GREEN. Once complete, (Link) light goes to RED as the transmitter turns off



Light Legend	Solid	Slow Flash	Fast Flash	Red Light	Green Light	Yellow Light	Alternating Red & Green Light

Diagnostics—T300 Transmitter



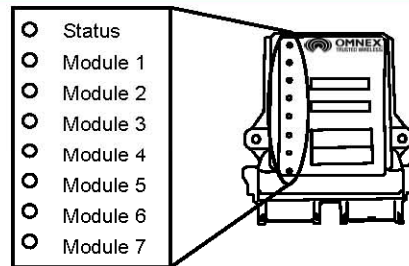

	Tether connection detected
	Low battery. Unit will run approximately 20 hours after Battery light starts flashing.
	The transmitter is in Calibration mode
	Power switch is stuck in the “UP” position.
	The Active light remain on momentarily when a function is activated (i.e. a switch or paddle is triggered). This is normal operation.
	Normal Operation The transmitter is in Download Mode.
	Normal Operation The Active light will flash 2 times per second, indicating that the transmitter is sending signals to the receiver.
	Stuck switch detected. Ensure that all switches are in a centered position. The transmitter will not power up when a function is ON.
	On Power Up Release the E-Stop button within 10 seconds to power up the transmitter, or the unit will power down.
	On Power Up Press and release the E-Stop button within 10 seconds to power up the transmitter, or the unit will power down.

Diagnostics - D180 Expansion Module





Indicator lights for the D180 Expansion Module



Status Indicator

 STATUS	Module is operating properly	 STATUS	Low battery condition detected
 STATUS	There is a fault with the module	 STATUS	Fuse blown
 STATUS	Communication to the module is active		

Module 1-7 Indicators

 MODULE	Module is installed and operating properly	 MODULE	There is a short to supply
 MODULE	There is a short to ground / over current	 MODULE	No Module installed

Light Legend	Solid		Slow Flash		Fast Flash		Red Light		Green Light		Yellow Light		Alternating Red & Yellow Light	





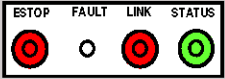
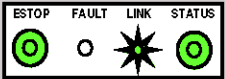
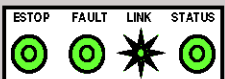
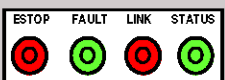

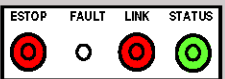
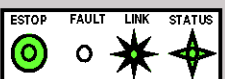

Diagnostics - R160 Receiver

Normal Operation

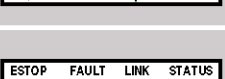
	Transmitter is OFF If the transmitter is off, the receiver is operating properly.
	Transmitter is ON When the transmitter is turned on, the Link light (fast flashing) and E-Stop (GREEN) indicates the receiver is operating properly
	Transmitter is in Operation When a function is activated on the transmitter, the Fault light will turn on GREEN. This indicates the receiver is operating properly
	Transmitter is OFF When a latched function is activated then the transmitter is turned off, the Fault light will stay on GREEN. If the system was intentionally designed this way, the receiver is operating properly, if not call for service.

Trouble Indicators

Note: In some cases, the indicator lights will be different depending on whether the transmitter is on or off. Please note the transmitter status in the "Description" column for each case.

Indicator Lights	Description	Solution
	Transmitter is ON The reason is the transmitter is not communicating with the receiver.	Refer to Trouble Shooting Chart #3 for solutions
	Transmitter is ON A low battery condition has been detected.	To detect intermittent conditions caused by poor or corroded ground or power circuits, the GREEN light will continue to flash for 30 seconds after the condition has been removed.
	Transmitter is ON An internal fault with the E-Stop has been detected.	Inspect E-Stop wiring for short circuit. Disconnect E-Stop wire as close to the receiver output as possible. If the Status light changes to: <ul style="list-style-type: none"> • GREEN, a short occurs after disconnection point. • Stays flashing RED, send it in for service .
	Transmitter is ON A short to ground or excessive current draw on an output. It is most likely caused by a wiring fault.	Ensure transmitter is functioning properly, check status of each output connection: Press each function button and observe Fault Light. <ul style="list-style-type: none"> • If GREEN, everything is OK. • If RED, there is a short in that connection.
	Transmitter is ON The E-Stop output has been connected with one of the other outputs	Follow the wire and check for connections with other wires, disconnect to see if condition clears. If not, call for service.
	Transmitter is OFF A wiring short to the battery has been detected.	Refer to Trouble Shooting Chart #1 for solutions
	Transmitter is OFF The receiver has detected an internal fault.	Refer to Trouble Shooting Chart #1 for solutions
	Transmitter is OFF Blown fuse detected.	Refer to Page 8 for instructions on how to open the receiver case to access fuse. Check wiring for shorts or bare spots. If fuses continue to blow, call for service.
	Transmitter is ON A setup failure has occurred.	Either hold the Setup button for 5 seconds to return to Setup mode or cycle power to return to the normal operating mode.
	Transmitter is OFF The receiver is powered incorrectly.	Most likely cause of this condition is that an output wire or the E-Stop wire has been connected to the power supply while the power wire is disconnected from the power supply.

Light Legend	Solid 	Slow Flash 	Fast Flash 	Red Light 	Green Light 	Yellow Light 	Alternating Red & Green Light 
--------------	---	--	--	---	---	--	---

Test the Receiver—R160

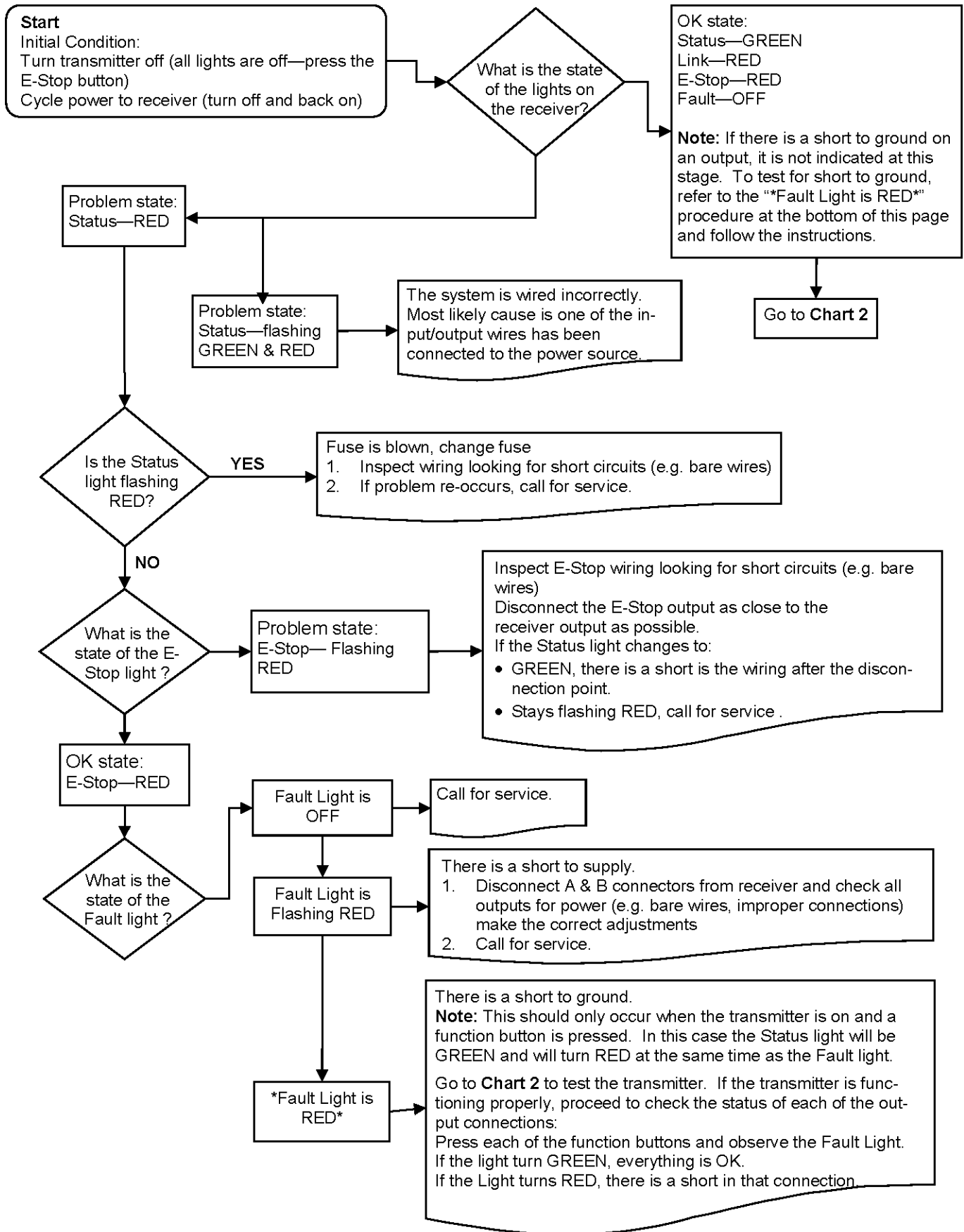

Test the Transmitter—T300

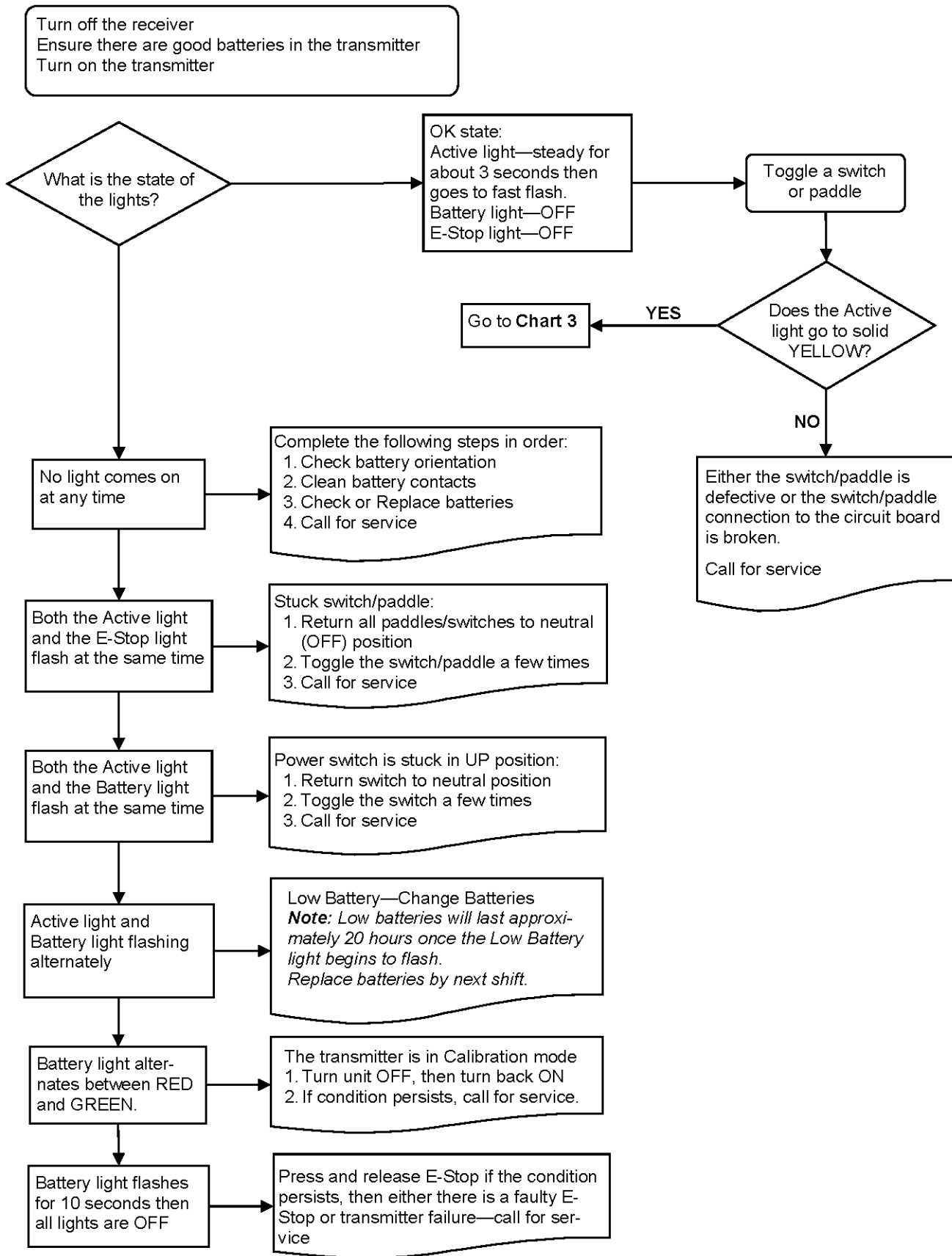

Testing the Transmitter / Receiver Communication

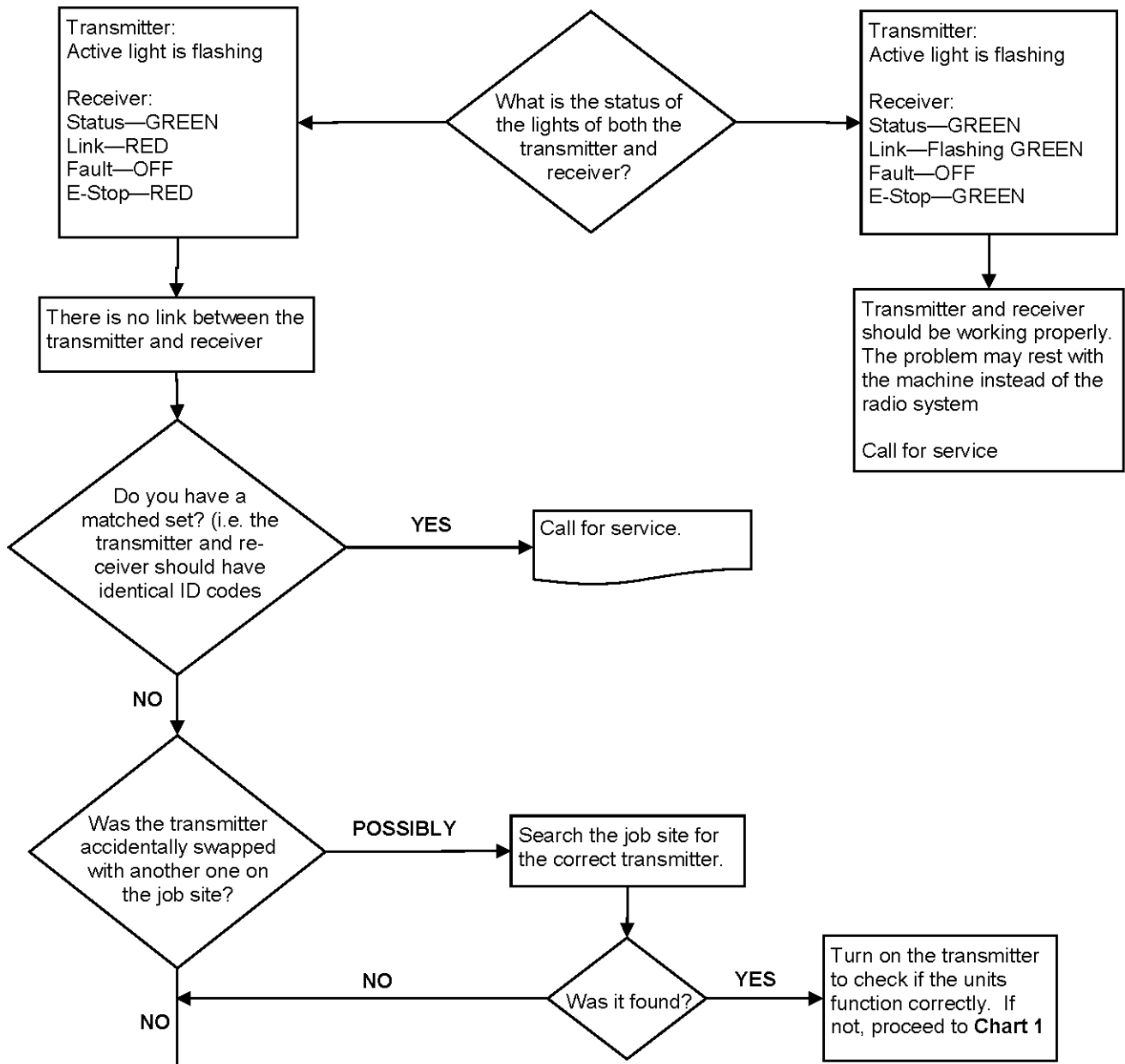

!!Caution!!

Note: Before you proceed with the Download ID procedure located on **Page 8**, great care and caution must be adhered to. Also, refer to **Chart #4** for Tips and Considerations.

If by accident, the transmitters have been switched with another unit, by downloading the ID code to a new receiver, it is possible for the transmitter to operate 2 units at the same time (if the original receiver unit is still on the job site). Therefore it must be certain that the transmitter / receiver pair are the correct set.

Secondly, once the download procedure is completed, ensure all other units on the job site are stopped. Test the operation of the newly configured set to ensure no other machines on the site work with the same transmitter.

Once you are certain that the transmitter / receiver pair are a unique set, continue normal operations.

Considerations when Downloading the ID

Potential downloading issues

If testing of the receiver and transmitter both show the system as working (Chart 1 & 2), then the transmitter and receiver will both go into Download/Configuration mode.

Possible issues could arise during Step 4, the download phase of reprogramming. In this case there are 2 symptoms to look for:

1. The Link light on the receiver will not turn GREEN when the power switch is toggled on the transmitter to download
2. The receiver will "time out" indicating that it didn't receive a signal from the transmitter within the 30 seconds from the time the receiver was put into Setup Mode.

If all indications appear normal during the download phase, test the link by turning on the transmitter (note: the transmitter shuts off after transmitting the ID code in Step 4)

1. If the Link light on the receiver doesn't turn GREEN, the receiver didn't receive all of the information that was sent from the transmitter.

Possible Solutions

1. Try the Downloading steps again
2. If this doesn't correct the problem, send both the transmitter and receiver in for service.

Note: you could try to determine whether the fault lies with the transmitter or receiver by completing the downloading procedure with a different transmitter. If this step works, then the fault lies with the original transmitter. If not, the fault may lie with the receiver.

!!Caution!!

Note: Before attempting downloading with another transmitter, understand that reprogramming the receiver with another transmitter, could result in two receivers on the job site responding to the one transmitter. If the original transmitter was sent in for repair, Disconnect the receiver (disconnect connector A) to continue using the machine without remote capability and without fear of inadvertently operating the machine with the other transmitter.

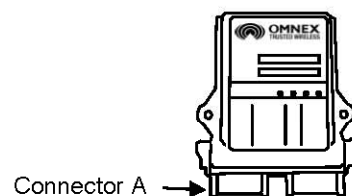

Reprogramming Tips:

1. Use a pointy instrument to depress the Setup button on the receiver (i.e. a pen) as the button is relatively small
2. Follow each step as laid out in the procedure
3. Never lay the receiver circuit board down on anything metallic (there are contact points on the back which could contact the metal and damage the receiver)

Parts & Accessories

Part	OMNEX Part Number	Description
Batteries	B0012	4 x "C" alkaline
Fuse	F0039	36V Bi-directional, Bussman ATC-15
Shoulder Strap	FMEC-2709-01	T300 Tear-away shoulder strap
Output Cable	ACAB-2493-01	R160 Output Cable, Generic
	ACAB-2493-03	R160 Output Cable, Generic, Tethered
Pendant Cable	ACAB-2455-01	Tether Cable, 10m
	ACAB-2455-02	Tether Cable, 8m
	ACAB-2710-01	Tether Cable, 4-12ft
Connector Kit	AKIT-2337-01	Includes Deutsch socket connectors, wedges, pins and sealing plugs
Bipolar Diode Kit	AKIT-2492-01	Motorola P6KE36CA



Shoulder Strap



Pendant Cable



Pendant Coil



R160 Output Cable

Specifications

	D180 Module	R160 Receiver	T300 Transmitter
Size	5.1" x 4.7" x 1.4" (130mm x 119mm x 36mm)	5.1" x 4.7" x 1.4" (130mm x 119mm x 36mm)	9.5" x 6.0" x 5.0" (240mm x 152mm x 127mm)
Weight	0.65lbs (0.295kg)	0.65lbs (0.295kg)	3.5 lbs (incl. batteries) (1.2kg)
Construction	High impact plastic, weather-proof	High impact plastic, weather-proof	High impact, low temperature plastic, weatherproof
Input Power	+9V to 30VDC	+9V to 30VDC	4C alkaline batteries
Battery Life	N/A	N/A	500 hours (continuous use)
Operating Temperature Range	-40F to 158F (-40C to 70C)	-40F to 158F (-40C to 70C)	-40F to 140F (-40C to 60C)
Outputs	3A (max) each (sourcing), 15A (max) each (combined)	3A (max) each (sourcing), 10A (max) each (combined)	N/A
Antenna	N/A	Internal	Internal
Approvals	USA - FCC part 15.247 Canada - ISC RSS 2210 Europe - EN 440 Australia- C-Tick		

FCC Rules and Compliance

This device complies with Part 15 of the FCC Rules. Operation is subject to the following two conditions: (1) This device may not cause harmful interference, and (2) this device must accept any interference received, including interference that may cause undesired operation.

FCC Part 15.247
ISC RSS 210

Warranty

OMNEX Control Systems Inc. warrants to the original purchaser that the OMNEX products are free from defects in materials and workmanship under normal use and service for a period of ONE YEAR, parts (EXCLUDING: SWITCHES, CRYSTALS, OR PARTS SUBJECT TO UNAUTHORIZED REPAIR OR MODIFICATION) and labor from the date of delivery as evidenced by a copy of the receipt. OMNEX's entire liability and your exclusive remedy shall be, at OMNEX's option, either the (a) repair or (b) replacement of the OMNEX product which is returned within the warranty period to OMNEX freight collect by the OMNEX APPROVED carrier with a copy of the purchase receipt and with the return authorization of OMNEX. If failure has resulted from accident, abuse or misapplication, OMNEX shall have no responsibility to repair or replace the product under warranty. In no event shall OMNEX be responsible for incidental or consequential damage caused by defects in its products, whether such damage occurs or is discovered before or after replacement or repair and whether or not such damage is caused by the negligence of OMNEX Control Systems Inc.

OMNEX Control Systems Inc.